

Congratulations on your choice of a Real Good Toys product. Your kit has been precision made with meticulous care by our craftspeople using carefully selected materials. This Dollhouse will last for years, even generations, if heirloom care and attention is given during assembly. Take your time and read the instructions completely. If you have questions, ask the experts at your local Dollhouse store or at info@realgoodtoys.com

Before you begin - You have already opened the box and see all the parts organized in boxes and bundles. For the moment, keep them that way. There are important things to do before you open your glue bottle.

Choose your color scheme. Look at houses in your community, models in your local Dollhouse shop or at our website: realgoodtoys.com; look at plan books from a paint store or architectural books at your library (a favorite is: *Painted Ladies* by Michael Larsen and Elizabeth Pomada). You will be painting some of the parts right away so get the paint now. Choose high-quality interior semi-gloss latex enamel paints for ease of use and durability.

Prepare your space: This dollhouse will spread out over a large area while it is being built. You will need a large flat tabletop for the house, several boxes to keep parts organized until they are needed, and several trays lined with waxed paper for holding small parts like windows and railings. A snap-lid box will keep your tools and supplies handy between building sessions.

Measure and identify the parts: The kit is packed in groupings that protect the parts, and that is how the Parts List is organized. As you measure and identify the parts, label them with sticky notes using the names from the parts list, and check them off the parts list so you know you have everything. Taking the time now to identify and organize the parts also makes them familiar so you will understand what the instructions intend as you read ahead.

- Plan ahead so you know where you are going
- Read ahead so you know how to get there
- Paint ahead so the parts will be ready when you need them



Tools and Supplies:

Tape measure or ruler, Pencil, Sticky notes (like PostIts®)
White glue (like Aleene's Tacky Glue®) for all construction
Solvent-based Panel Cement for shingles
Masking tape, Utility knife or coarse file
Fine tooth saw (razor saw (like X-Acto®) or a hacksaw)
Painting Supplies, Sandpaper (especially 320gr)
Waxed paper
PostIts®, Aleene's®, and X-Acto® are registered trademarks of their manufacturers and have no affiliation with Real Good Toys

Options: www.realgoodtoys.com or your miniature dealer
6888: the "Best 1" Dollhouse Electrical Kit
Stucco Grit: Paint additive for foundation texture
Dye-1: Brown shingle dye
Dye-3: Grey shingle dye
SC: Copper flashing
1015: 6-panel interior doors for Dividers
J-FK Interior finishing materials: Baseboard and crown moldings & stairway banisters and landing rails.

This kit will accommodate 1" Scale furniture



Not suitable for children under 13 years of age
California 93120 compliant for formaldehyde phase 2

Identify the parts: Open one bundle at-a-time. Measure each part and find it on the parts list. Label the parts and mark the parts list so you know you've found everything.

Box A Parts

- (1) E9626 Dormer Front Wall: (1/4 clapboard) 9 1/4 x 10 1/2, peaked, window cutout
- (1) E9624 Dormer SideWall Left: (3/8 clapboard) 57/8^{tall} x 47/8^{top}, angled
- (1) E9625 Dormer SideWall Right: (3/8 clapboard) 57/8^{tall} x 47/8^{top}, angled
- (2) E9629 Handy Square: (1/4) Triangle ±2 3/4"
- (1) E9637 Front Step Tread: (1/4) 8 1/4 x 17/16
- (1) E9645 Chimney Block: (1 x 1 3/8) 4 1/4, angled
- (1) E9646 Chimney Cap: (3/8) 1 1/2 x 1 1/8
- (1) E9647 Chimney Cap: (1/4) 1 x 1 3/8
- (3) E9649 Postbase Front: (1/8) 1 5/8 x 4 3/4
- (2) E9650 Postbase BackEnd: (1/8) 1 5/8 x 4 3/4 Inlet
- (1) E9651 Postbase Back: (1/8) 1 5/8 x 2 3/4
- (4) E9652 Postbase Side: (1/4) 1 3/8 x 4 3/4 Inlet
- (2) E9653 Postbase SideEnd: (1/4) 1 3/8 x 4 3/4
- (3) E9655 Postbase Cap: (1/4) 1 7/8 x 1 7/8
- (2) E9654 Post Cap: (1/8) 1 3/16 x 1 3/16 notch
- (1) E9803 Stair Stringer: (1/8) 3 3/4 x 10 7/8, angled
- (1) E9812 Window Pane 5 x 6
- (1) E9813 Window Pane 4 x 6
- (2) E9643 Arch: (1/8) 3 3/8 x 2, shaped.
- (1) U1119A Oval Light Door, assembled
(set) Door Interior Trim

Drawings are not all the same scale

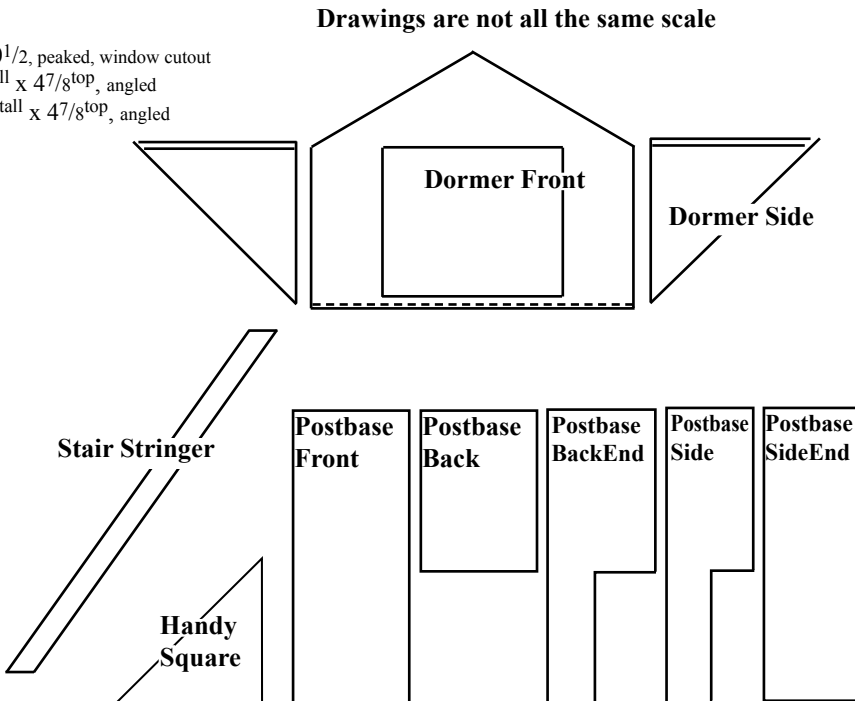

Box B Parts

Rail Pack:

- (2) E9659 Porch Rail: (W) 12 1/8
- (4) E9660 Porch Rail: (W) 3 15/16
- (32) E9661 Baluster: (1/8 x 5/16) 2 1/8



Cross Sections

Brackets Pack

- (18) E9663 Porch Rafter End: (3/16 x 5/16) 1 5/8 angled
- (6) E9664 Dormer Rafter End: (3/16 x 5/16) 1 3/16 angled
- (14) E9665 Bracket Base: (1/8 x 3/8) 1 1/2
- (14) E9666 Bracket Strut: (1/8 x 3/8) 1 3/4 angled
- (10) E9667 49° Bracket Cap: (3/8 x 3/8 angled) 1 1/4
- (4) E9668 35° Bracket Cap: (3/8 x 3/16 angled) 1 1/4

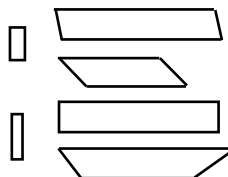

Porch Rafter End

Dormer Rafter End

Bracket Base

Bracket Strut

Window Frame Pack

- (4) E9804 6" Window Frame: 6 5/16
- (2) E9805 5" Window Frame: 5 5/16
- (2) E9806 4" Window Frame: 4 5/16
- (2) E9810 Middle Frame: 4 7/16
- (2) E9811 Middle Frame: 3 7/16
- (4) E9808 Interior Trim: (3/32 x 7/16) 6 5/16
- (2) E9809 Interior Trim: (3/32 x 7/16) 5 5/16
- (2) E9807 Interior Trim: (3/32 x 7/16) 4 5/16
- (2) E9662 Spacer (window): 1 1/2
- (1) E9648 Groove-Fill: (1/16 x 3/8) 4
- (950) E9814 Shingles: (1/16 x 3/4) 1 1/4

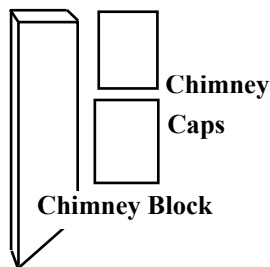
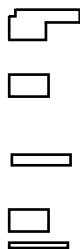

Chimney Caps

Chimney Block

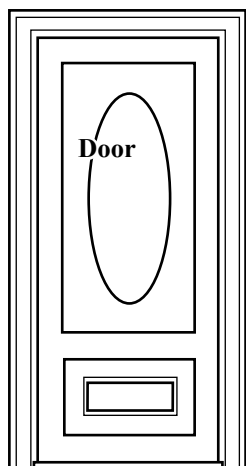
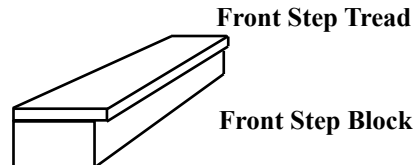
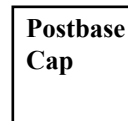

Door Interior Trim



Window Frame

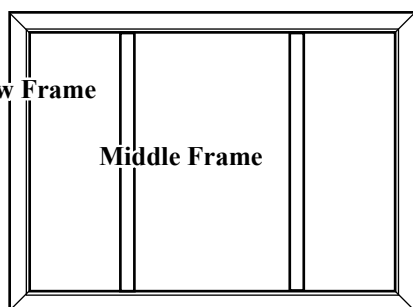

Middle Frame

Window Panes

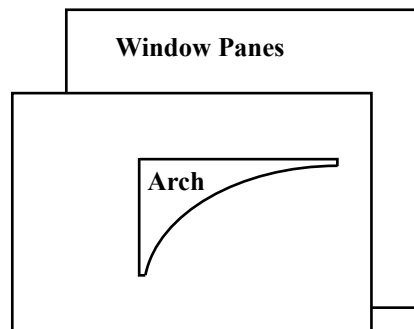



Arch

Panels

- (1) E9630 Porch Floor: (1/4) 23¹³/₁₆ x 4³/₄
- (1) E9621 Front Wall: (1/4 clapboard) 11¹/₈ x 24³/₁₆, cutouts
- (1) E9622 Side Wall Left: (1/4 clapboard) 21⁵/₈^{tall} x 11⁷/₈, angled
- (1) E9623 Side Wall Right: (1/4 clapboard) 21⁵/₈^{tall} x 11⁷/₈, angled
- (1) E9638 Dormer Roof Left: (1/4) 9⁷/₈^{top} x 7¹⁵/₁₆, angled, bevels
- (1) E9639 Dormer Roof Right: (1/4) 9⁷/₈^{top} x 7¹⁵/₁₆, angled, bevels
- (1) E9631 Mid Floor: (3/8) 23¹³/₁₆ x 11¹⁵/₁₆, woodgrain, stair hole
- (1) E9632 Base Floor: (1/4) 23¹³/₁₆ x 11¹⁵/₁₆, woodgrain
- (1) E9627 Divider: (3/8) 9 x 11⁷/₈, door cutout
- (2) E9628 Attic Divider: (3/8) 12 x 11⁷/₈, angled, door cutout
- (1) E9636 Front Step Block: (3/4) 8¹/₄ x 1¹/₄
- (2) E9640 Foundation, Long: (3/8) 23¹³/₁₆ x 1³/₄, grooved
- (2) E9644 Porch Post: (1 x 1) 5
- (1) E9634 Rear Roof: (1/4) 27³/₁₆ x 4³/₄, attic cutout
- (1) E9635 Porch Roof: (1/4) 27³/₁₆ x 7¹/₁₆, bevel
- (1) E9633 Front Roof: (1/4) 27³/₁₆ x 14¹/₁₆, dormer cutout *along the side*

Stripwood Pack

- (4) E9656 Rafter Material: (3/16 x 5/16) 20 
- (4) E9657 Stripwood: (3/32 x 7/16) 20 
- (6) E9658 Stripwood: (3/32 x 5/16) 24 
- (1) E9642 Porch Beam: (1 x 1³/₈) 24¹³/₁₆, shaped
- (1) E9620 Attic Ceiling: (3/4 x 1³/₈, triangular) 23¹¹/₁₆
- (3) E9641 Foundation, Mid: (3/8) 16³/₈ x 1³/₄
- (1) E9801 Bottom Stair Block: (6-step) 2¹/₄, bottom bevel
- (1) E9802 Top Stair Block: (6-step) 2¹/₄, top bevel

Long Foundation (front & back)

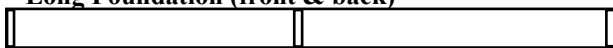

Mid Foundation

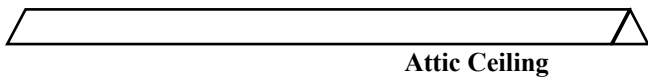
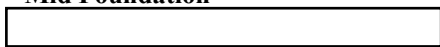

Attic Ceiling

Porch Beam

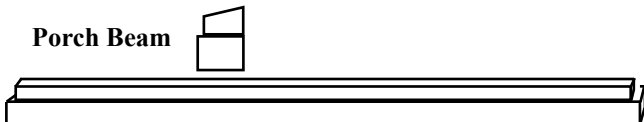

Top Stair Block

Bottom Stair Block

Dormer Roofs

Side Wall

Front

Porch Roof

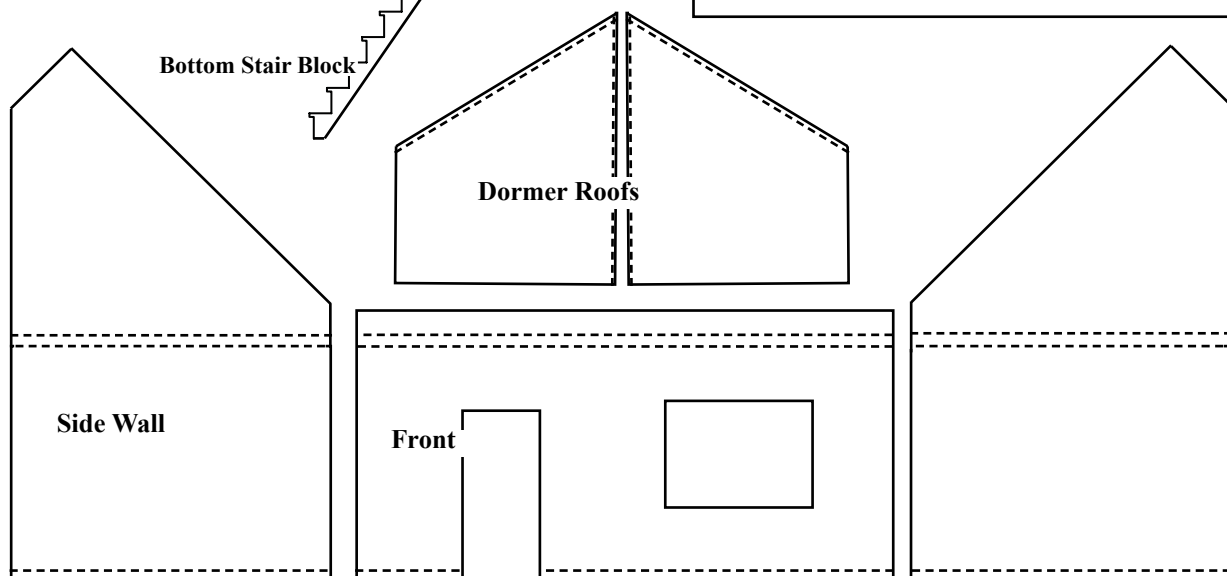
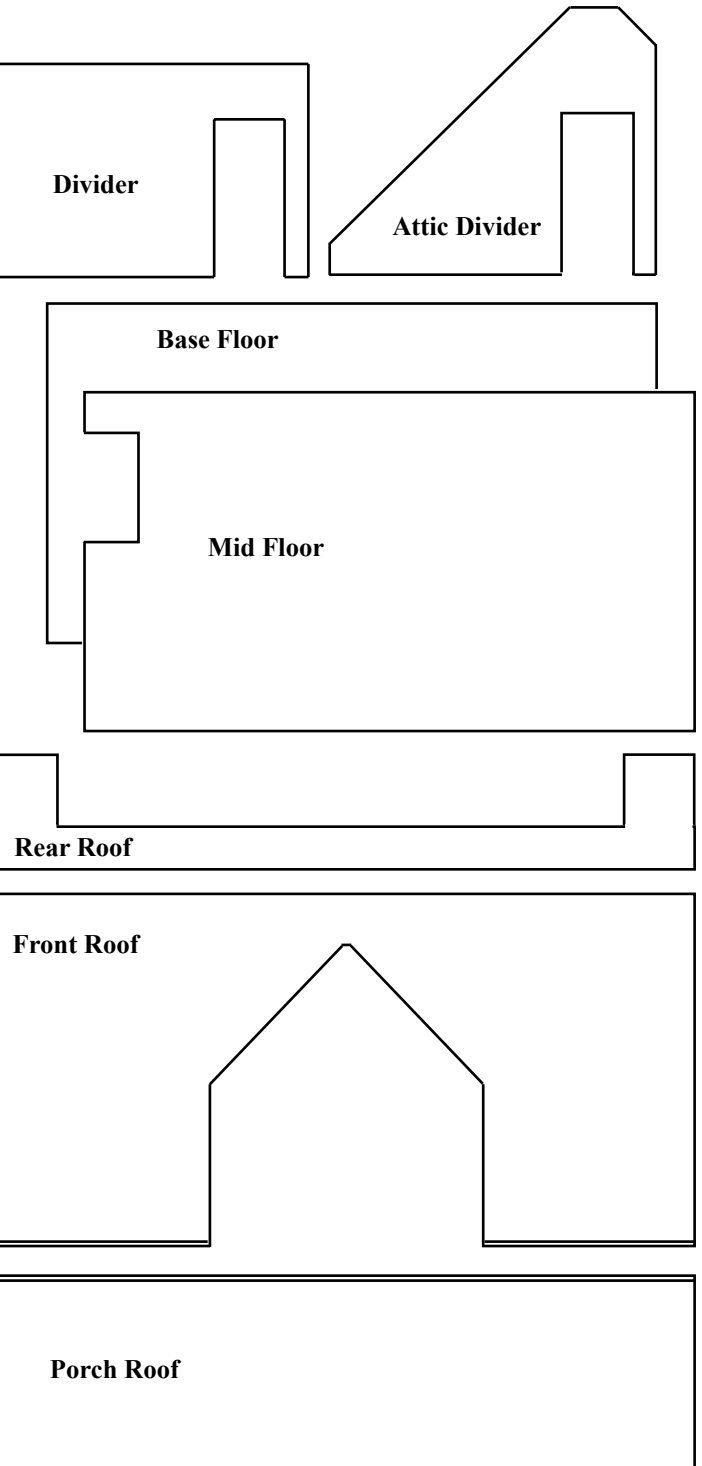

Clapboard

Options for building the Beachside Bungalow Dollhouse

See your dealer or www.realgoodtoys.com

Exterior:

Exterior Paint Color:
see www.realgoodtoys.help for suggestions

Accessories:

- Gingerbread
- Flower Boxes
- Foundation Stucco Grit
- Octagonal Shingles
- Fancy Windows and Doors
- Turnposts and Spindles

Interior:

- Wiring
- Wallpaper
- Interior paint color:

- Ceilings
- Painted walls
- Interior trim

Flooring:

- Applied wood, tile, or carpet
- Banister & Landing Rails
- Baseboard and Crown



DH
A Doghouse for your Dollhouse

Wallpaper



HH-444
P-2000

Slideshows, demos, useful links, details, and photos are all at:

www.realgoodtoys.help

Exterior



#6018

Doors:



#6022

Interior



#1015

Note: I often enlarge an interior door opening to fit the #6022

Split Octagonal Shingles

Pine: HOW500
Cedar: HOC350



Shingle Dye



Dye1: Reddish Brown
Dye3: Dark Grey

T10 Turntable (12" - holds 1000 lbs),
T250 Assembled Turntable, and
ET250 Wired Turntable



Trim and Stripwood



RGT8



Real Good Toys' Best!
Dollhouse Wiring Set



#4017 Stair and Landing Set



6803 Banister & Landing Set

Assembly Notes:

A large, clutter-free, well-lighted work area is helpful during assembly, but a flat work surface is essential.

Read the instructions carefully; look at each of the illustrations. **!With the parts in your hands!**, think the assembly through before you proceed.

Test fit each time you are ready to glue a piece in place...then you'll know you have it right.

If more tape or a helper is needed, it's good to know that before the parts have glue on them.

Don't be stingy with glue or tape; use generous amounts. Always wipe off excess glue immediately.

Keep one damp rag and one dry rag handy all the time.

Have weights available for holding things tight as glue joints dry (stacks of books, gallons of pure Vermont Maple Syrup - anything heavy)

Glue the body of your dollhouse together with white, water clean-up glue that dries clear. Do not use instant-bond (super glue), fast-tack, rubber cement, silicone, or hot melt glues. They are all used in some wood applications, but they all have some characteristic that makes them un-desirable for the body of your dollhouse. Carpenter Glue works well, but glue-smear dries yellow or tan; many of the things you glue onto the house are pre-painted – extra glue will show. I use Aleene's Tacky Glue® for all house body assembly.

Make sure everything is straight and flat as glue dries... That's the shape that will be permanent.

Glue the shingles on with glue that doesn't have any water in it! If the glue says "water clean-up", it will curl the wooden shingles. Look carefully at the glue you intend to use to be sure it is solvent-based, or use hot-melt glue (and watch out for the burns). Check ingredients and warnings! Solvent-based glues say "Caution, Flammable".

If you Wallpaper, use Universal Bander Paste®.

Brush paste on the wallpaper, then the wall, and finally smooth the wallpaper into position.

When glue is drying, skip ahead to up-coming assembly steps and prepare the parts that will be used.

Before you begin, read the "Finish the Inside" section on the last page.

Wiring? Some of the steps are easiest before and during assembly. See www.realgoodtoys.help to plan your wiring project

A: Getting Started: Do these things before the house assembly

Square the corners of the window, door, and stair holes with a utility knife - each cutout has a rounded corner left over from the tool that made it.

Make two cuts in each corner from the outside (one from each direction), then cut from each direction on the inside to cut away the rounding in the corner so the window, door, or stairs will fit.

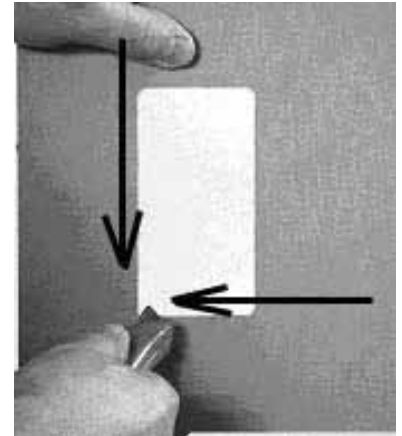

Stain the Shingles: Our pro uses Real Good Toys' Shingle Dye (available through your miniature dealer or www.realgoodtoys.com) when dyeing the shingles for this house.

You can also use a *penetrating* stain (like "Minwax"). Do not use *surface-coating* stain to batch-finish the shingles.

Batch dye or stain the shingles several days ahead of time so they will be dry when the time comes to use them (instructions are with the shingle dye).



OnLine Support: There are many photos of Dollhouses under construction as well as tips, techniques, and extra help with your dollhouse project at: www.realgoodtoys.help

Put a finish on the floors now to protect them from tape and from the mess and the wear-and-tear of construction.

Do not use penetrating stain on these floors. Use a surface-coating finish like acrylic urethane or a “one-coat” stain + finish like “Poly-Shades” (polyurethane mixed with stain). Wipe the first coat off completely and, when dry, take off the shine with very fine abrasive (a used scotch-brite pad is ideal), then put on a full thickness second coat.

www.realgoodtoys.help has more on floor finishing as well as painting and sanding videos



B. Painting:

Paint (first-coat) everything that will be painted in the finished house (do not paint surfaces or edges that will be glued). Don't try to sand, fill, primp, or do much of anything to the wood before the first coat. The first coat fills and reinforces the wood so sanding clips off the fibers rather than pushing them around. The first-coat is all about what penetrates and fills the wood. There is no expectation that more than a hint of paint will be on the surface. Don't 'double paint' or try to give it an extra thick first coat as you watch the paint soak in... that is expected and preferred.

The first benefit of painting before assembly (one-coat) is that it is the easiest time to do a really thorough job of sanding after painting. The difference between a heirloom-grade finish on a dollhouse and a “I-was-in-a-hurry” finish is most often the quality of the sanding, and it's hard to sand into the little hidden corners of an assembled dollhouse, but it's easy to sand the flat panels layed out on a workbench.

So **sand everything now** - sand until the paint is smooth and transparent with no scratchiness to it, and with lots of wood showing through the paint. For the clapboard walls, sand “one clapboard course at-a-time”: fold the sandpaper and hold it on your finger-tips, then sand back-and-forth across one clapboard's surface 2 or 3 times, then move up to the next clapboard. “One at a time” is what makes it smooth and “Heirloom-Great”.

Second coat everything after building the housebody up to the top of the Walls (before attaching the Roof). The second coat goes on smooth and creamy, and except for touchup, it may be enough.

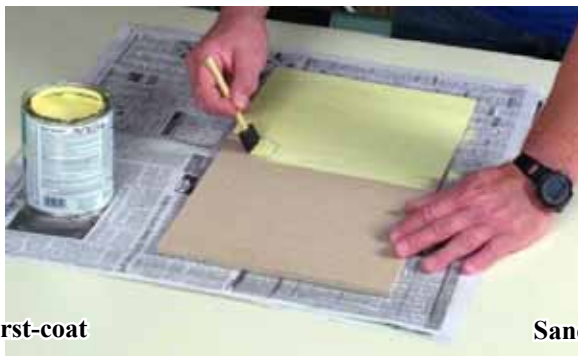

First-coat



Sanding one course at a time

Where two colors of paint will be next to each other, the neatest result will be achieved if the parts are marked and painted to just cover the mark, leaving the rest of the joint un-painted. That way, when they are glued together, the glue joint will have wood for strength (glue doesn't stick well to paint), and the joint between colors will be perfect (impossible to achieve with masking for painting)

Q: How can I prevent glue from seeping onto the floor after I clamp (tape) the Sides together?

A: Do not skimp on the glue... a little squeezing out tells you that there's enough glue in the joint. Clean up the squeezings with a damp rag followed by a dry rag, and the little bit that remains down in the grooves will shrink back as it dries, and will not be visible.

This issue is one of the reasons it is important to pre-finish the floors before assembly. I know, the finish tries to bead up when you first put it on and it is 'paint-can-runny', but as you wipe the first-coat off just keep rubbing it out as it loses its excess moisture and starts to get tacky - that first coat will eventually behave itself and lay down properly. I like to do the first-coat-rub-out with a crumple of brown paper bag so I can rub vigorously and 'de-shine' the print flooring, but other builders report success with just brushing and brushing until the moisture level gets right. After the finish is dry, do a very light de-shine with a non-woven abrasive pad (like 'Scotch Brite', the green pad you use in the kitchen for stainless steel pots... a used one is just right), and then do a second coat.

Clean the edges and grooves before assembly. A little paint always builds-out the corner of an edge or groove and will make assembly harder and the glue joint less strong. Test the Floor in their grooves to see that they fit well.

Cleaning a groove with the back of a utility knife blade



Can I do it differently? *Yes you can - it's your house!*

The information on these pages is offered as "best practices" advice, and it is what we do when we build this house.

If you are customizing or have something else in mind, test-ahead to make sure your planning includes *everything!*

A Railing Assembly demo is available online at www.realgoodtoys.help

1. Rail Assembly

A. 1. Paint (the first coat) and sand the Rails before assembly. Wipe any paint out of the grooves, and do not paint the Rail ends at all (wipe the ends to eliminate paint that sneaks around the corner). Paint the Ballusters.

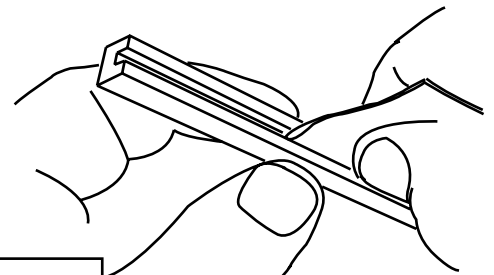

2. Sand (320 grit) the Rails and Ballusters. Sand the Rail's grooves with a folded piece of sandpaper.

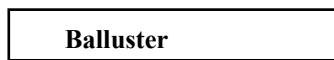

Paint (one coat) and Sand the Rails and Ballusters

Remove the last page from the instructions; cut and join the diagrams for a Railing Assembly Diagram large enough for the 12¹/₈" Railing.

B. Assemble the Railing:

1. Set one Rail on the assembly diagram, lined up on each end; tape it in place so it won't move. Put a dab of glue on a Balluster end, and push it into the groove at a balluster locator on the diagram. Straighten and adjust the Balluster to exactly line up with the diagram, then put in the next Balluster.

Repeat until all the Ballusters are in place. Do a final inspection and adjustment.

2. Support the Ballusters with a piece of stripwood; dab a little glue onto each Balluster end. Hold the second Rail over the Balluster's ends at an angle.

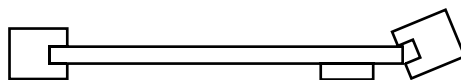
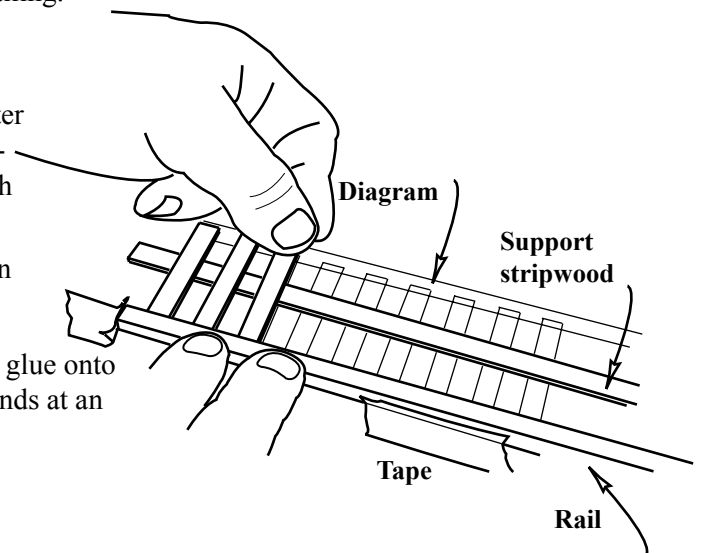

Push down and scoop the Ballusters' ends into the groove.

3. Squeeze the Rails together so the Ballusters are fully in the grooves.
4. Hold the Railing set on the drawing; make the Rail ends exactly line up. Adjust the Ballusters - - straight and square. Tape together Dividers to form a square inside corner, and lay the Railing in the corner as the glue dries - keep the ends square!

C. Paint (second-coat) the Railing

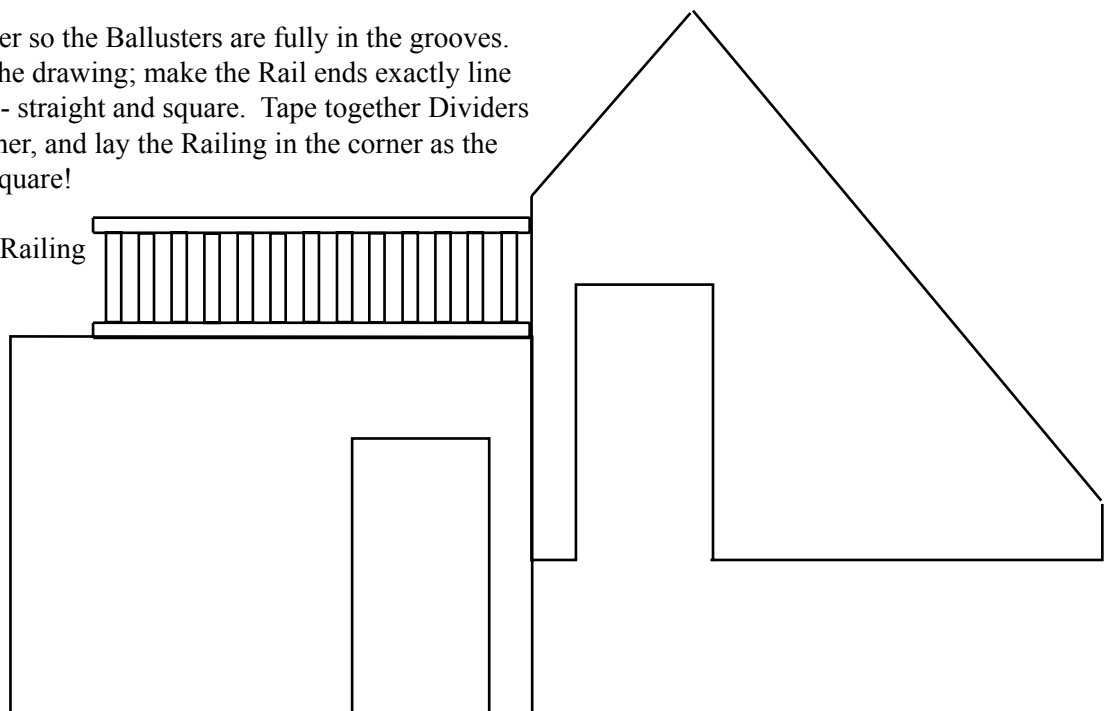

⇒ **2 Foundation.** Glue and tape the Foundation Longs (23¹³/₁₆"") and Foundation Mids (16³/₈"") together.

Tape the Base Floor to the Foundation to hold it square as the glue dries. If you haven't put finish on the Base Floor yet, tape it up-side-down so the tape won't damage the flooring (see "Put finish on the floors now", page 7).

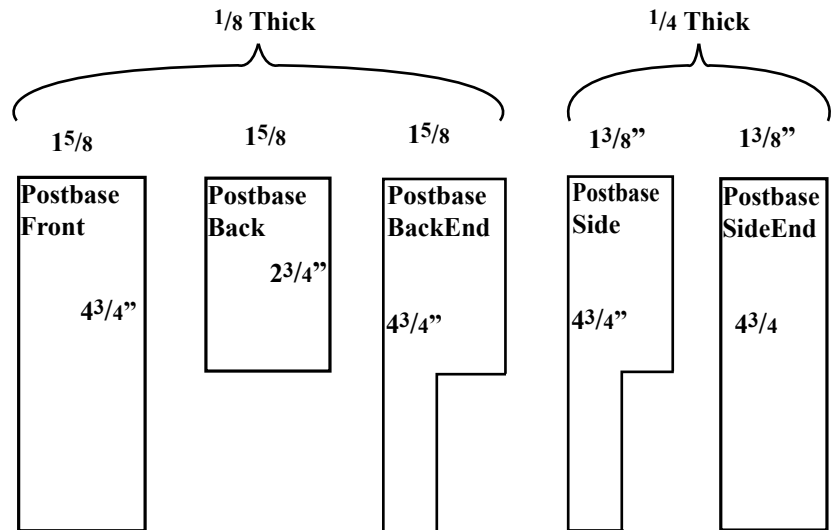
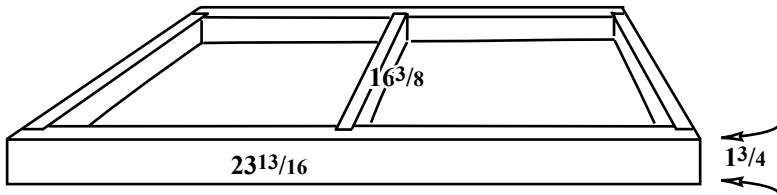
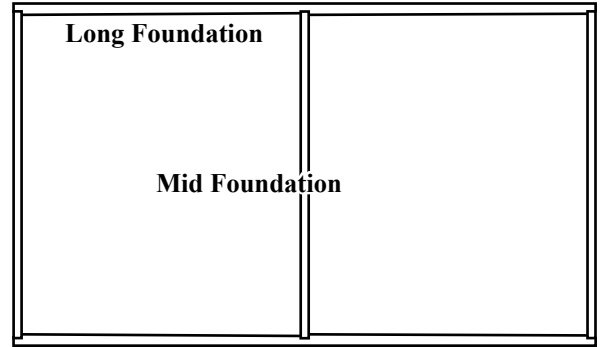

⇒ **3. Porch Posts:**

A. Sort the Postbases into these 5 categories:

3B Center Postbase:

- (1) Lay one Postbase Front flat; glue and tape two Postbase Sides to it, lined up on the edges.
- (2) Glue and tape a Postbase Back to the assembly.
- (3) Line up the edges and ends, with extra attention to the edges in the cutout.

3B (3) up-side-down
Line up the parts in the cutout

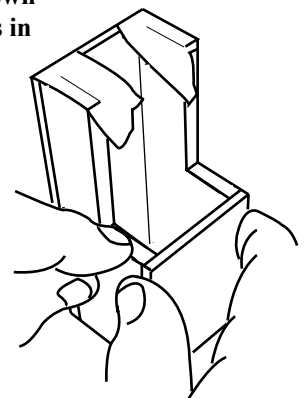
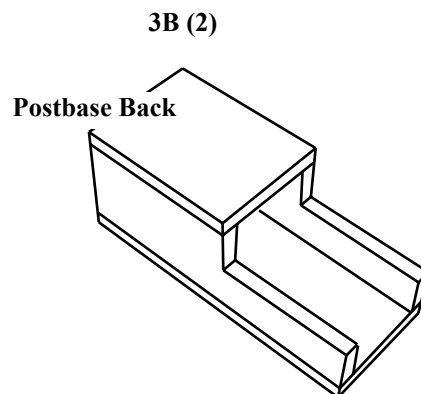
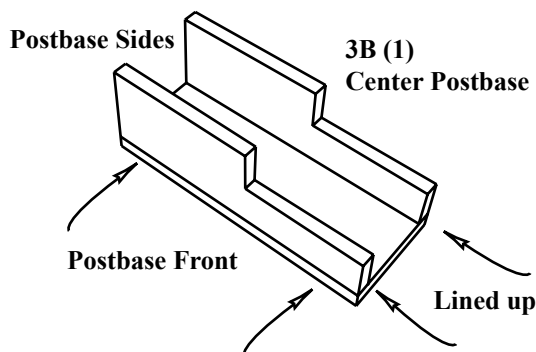

3C End Postbases:

(1) Lay two Postbase Fronts flat, glue and tape one Postbase Side to each, lined up on opposite edges to make one left set and one right set.

(2) Glue and tape a Postbase SideEnd to each assembly.

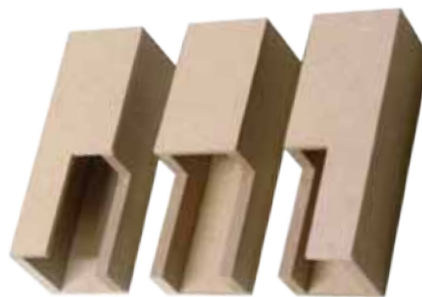

3C (1)
Left and Right Sets
are mirrors of each other

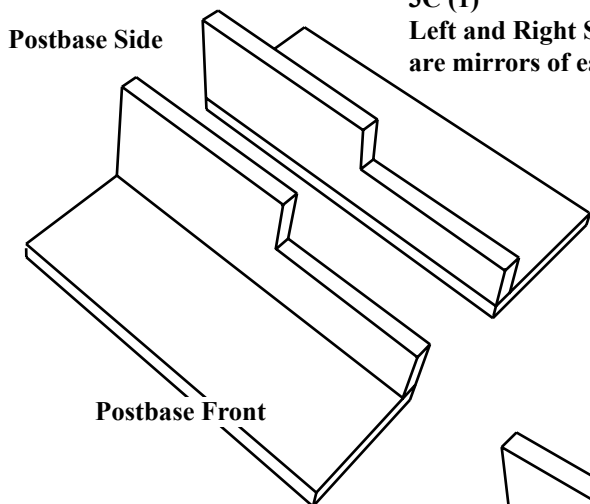

3C (2)
Left set

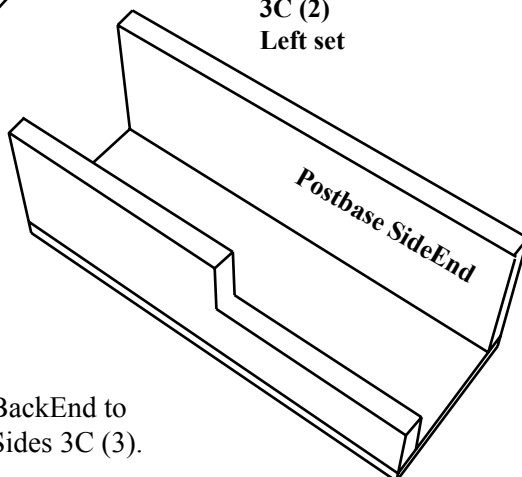

3C (3) Left Set viewed from the bottom
Right set is the mirror

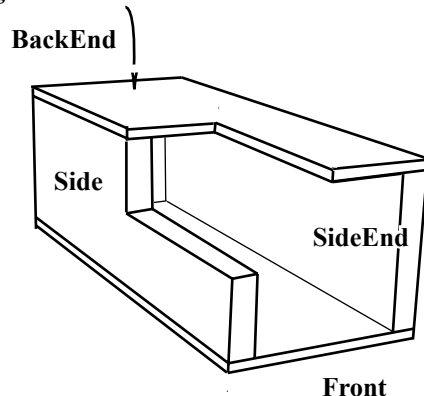

(3) Glue and tape the Postbase BackEnd to the back edges of the Postbase Sides 3C (3).

(4) Line up the edges and ends with extra attention to the edges in the cutout.

Let the glue dry, then paint the Postbases.

Texture Paint: Real Good Toys' "Stucco Grit" mixed with paint is tough and good looking on Foundations, Postbases, and the Front Step Block. Paint (one coat) the base color and sand now, and apply the paint + grit during final assembly.

⇒ 4. Glue the Porch Posts to Post Caps, centered.
Pro tip: I usually paint the Porch Post and Post Caps the same color, so I paint them (one coat) first, sand them, glue them together, and paint them again (second-coat).
Note: the notch is for an arch (see page 20).

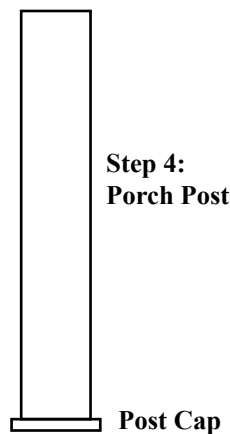

5. Glue the Porch Posts to PostBase Caps, centered.
Look from every angle to make sure the Posts are straight.



⇒ □ 6. Glue, tape, and weight the Porch Floor to the Foundation, carefully lined up on the edges. Finish painting the Porch Floor before you attach the housebody to this assembly in step 11 (not now!).

Wiring? Some of the steps are easiest before and during assembly. See www.realgoodtoys.help now to plan your wiring project.

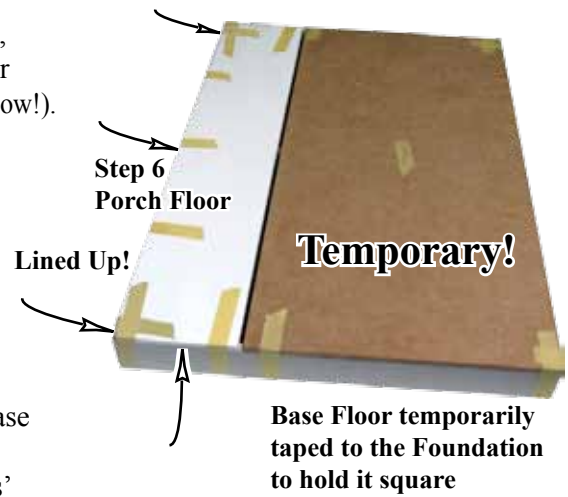

⇒ □ 7. A. Spread glue in the grooves of both Sides. Tape the Base Floor to the Sides, lined up in back (the floor sticks out 1/16" in front). Make sure the Floor is all the way to the top of the Sides' grooves.

B. Set the Mid Floor into the grooves lined up in back (the floor sticks out 1/16" in front), and with the stairhole closer to the front (up). Hold the Sides tight onto the Mid Floor with a piece of tape above where the Front will attach so the tape won't be in the way.

C. Glue and tape the Groove-Fill into the exposed groove within the stairhole.

Step 7A: front edges are up
The Base Floor sticks out 1/16" in front

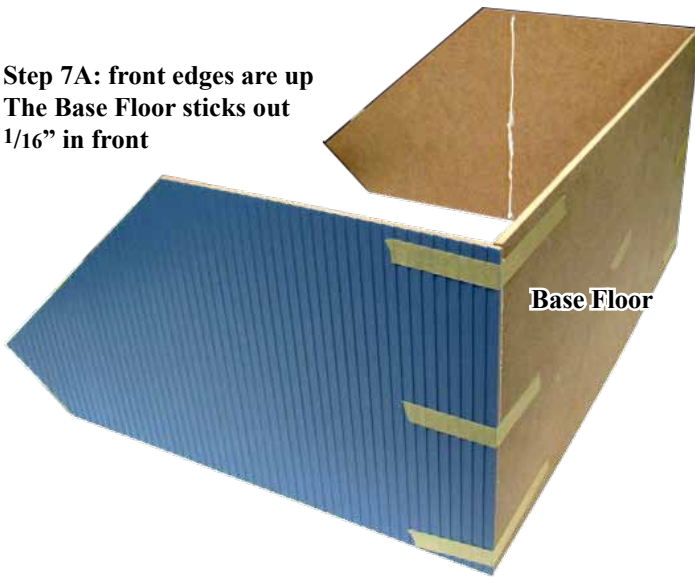

Step 7B: front edges are up
The Mid Floor sticks out 1/16" in front

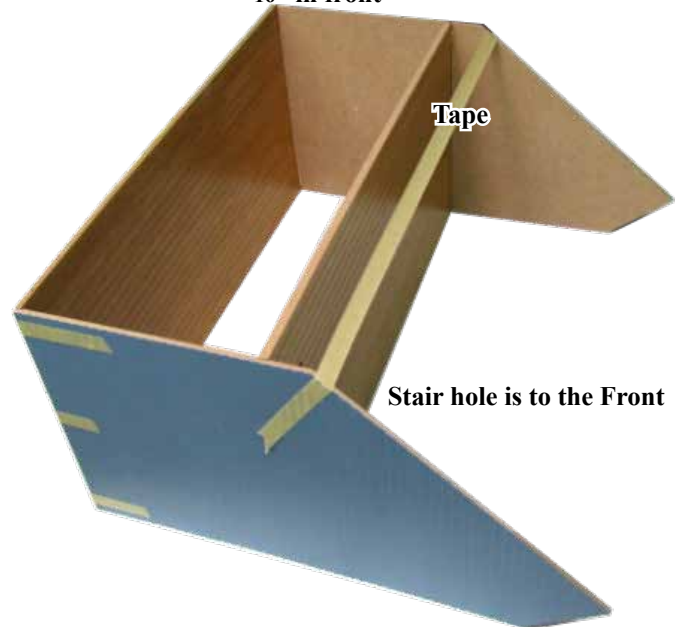

Step 7C: Groove Fill



- 7. D. Glue and tape the Front to the Sides and Floors.
- Line up the bottom corners side-to-side - tape the Front to the Base.
- Line up the top corners side-to-side - tape the Front to the Sides.
- Make sure the Base is all the way to the top of the Front's grooves.
- Put the Divider between the Floors.
- Stand the Housebody upright and check the fit of all the parts.
- Tape (more tape!) the parts together so all joints are tight.
- Lay the Housebody on its back, weight the Front.
- Check: the Base Floor is all the way to the top of the groove.

Step 7D: Line up the Front side-to-side, tape along the bottom

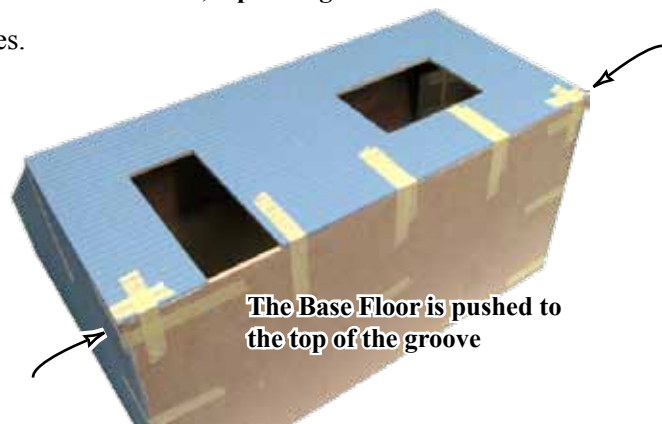

Line up and tape along both sides

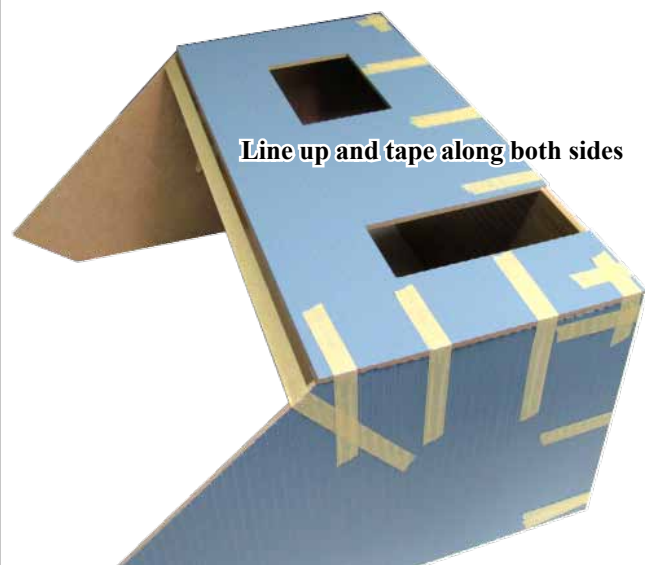

Tape all the way around the housebody to hold the parts tight

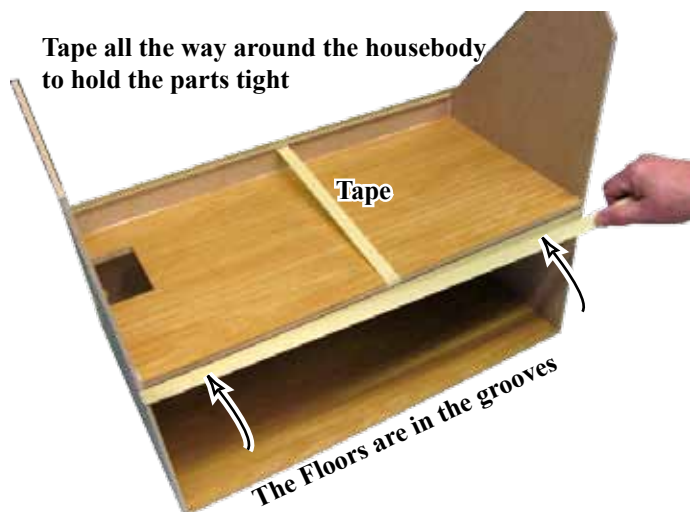

- 7. E: Glue and tape the Attic Ceiling to the Sides, lined up on top.
- Check that the floors are lined up in back and in the grooves in front.
- Lay the Housebody on its back, weight the Front.
- Check that the Base Floor is all the way to the top of the groove.
- The Divider between the floors holds the perfect spacing.
- Let the glue dry.

Lined up on top

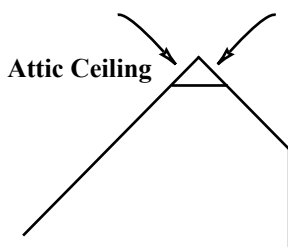

Weight the Front

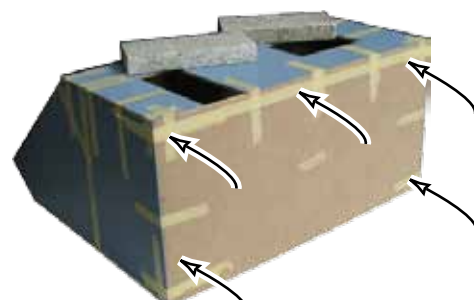

Check that the Base Floor is pressed to the top of the groove

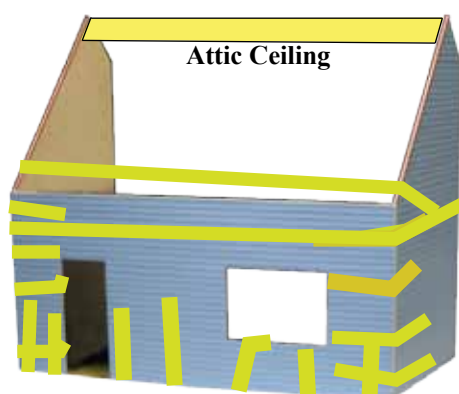

⇒ 8 Draw Shingle Guidelines spaced 1" apart, starting from the top of each roof. Look at the drawings to identify the outside of the Roofs (a dotted line shows a beveled edge that faces down).

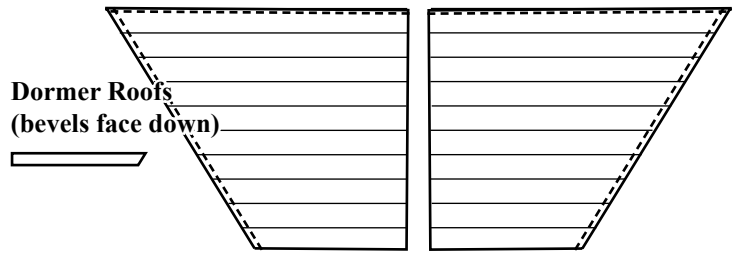

Dormer Roofs
(bevels face down)

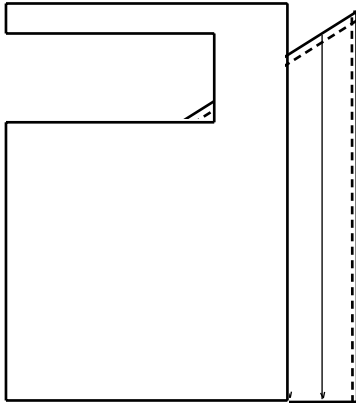

Stand the Dormer Roofs on their front edges and use a divider to extend the marks for shingle lines.

Rear Roof
(bevel faces down)

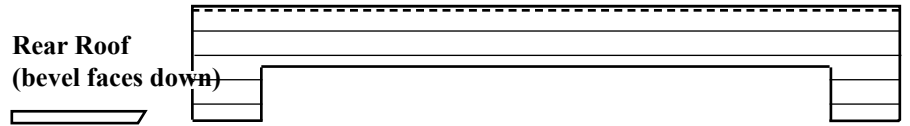

Front Roof
(bevel faces up)

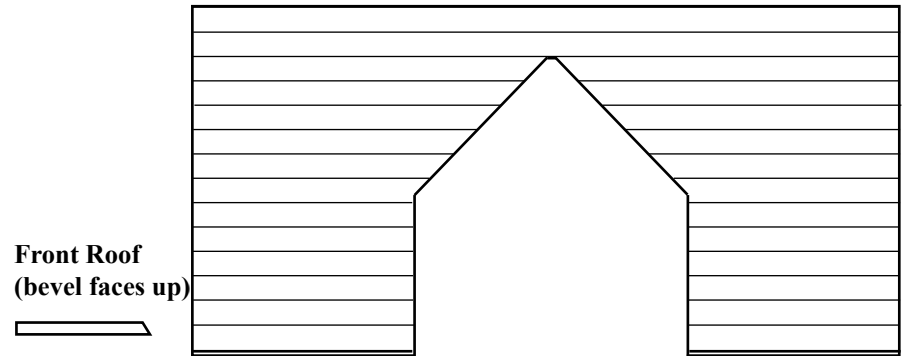

Porch Roof
(bevel faces up)

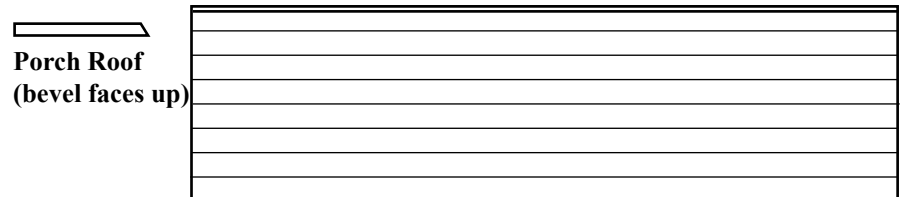

⇒ 9 Turn the Roofs over and draw painting guidelines spaced from the edges as shown. Paint to just barely cover the lines.

Note: these are guidelines for the eave paint (outside of the walls). For ceiling paint, draw a second guideline $1/8''$ inside the first (see below).

Pro Tip: Paint the interior ceilings with one coat, and sand them now. Leave about $1/8''$ unpainted for gluing the Roof to the Walls. Sand until the paint gets transparent and the wood begins to show thru (this allows Dividers to be glued in). Paint the second coat after assembly is done.

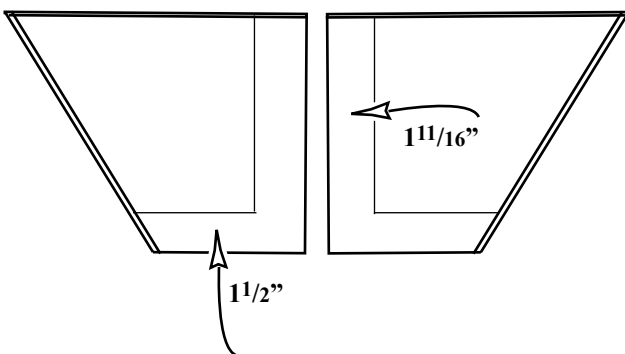
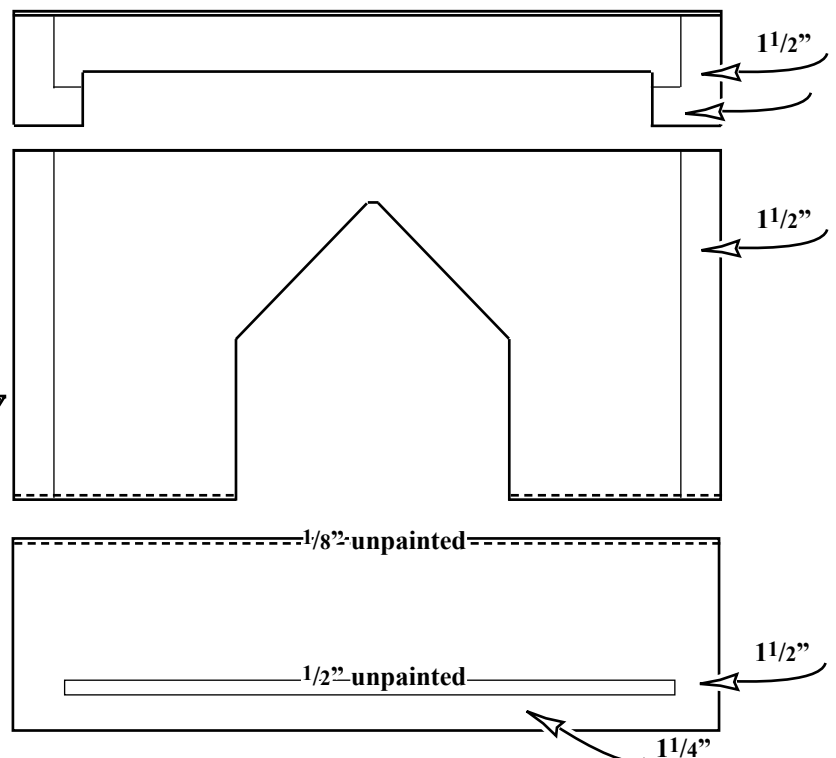

⇒ 10. Glue and tape Dormer Sides to the Dormer Front, lined up at the top. Tape Handy Squares into the assembly to hold the Sides square.

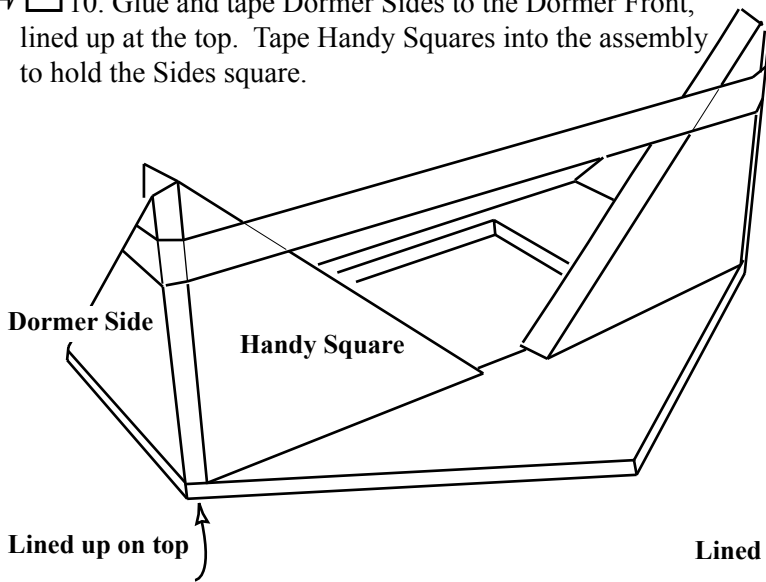

Prepare flaps of tape

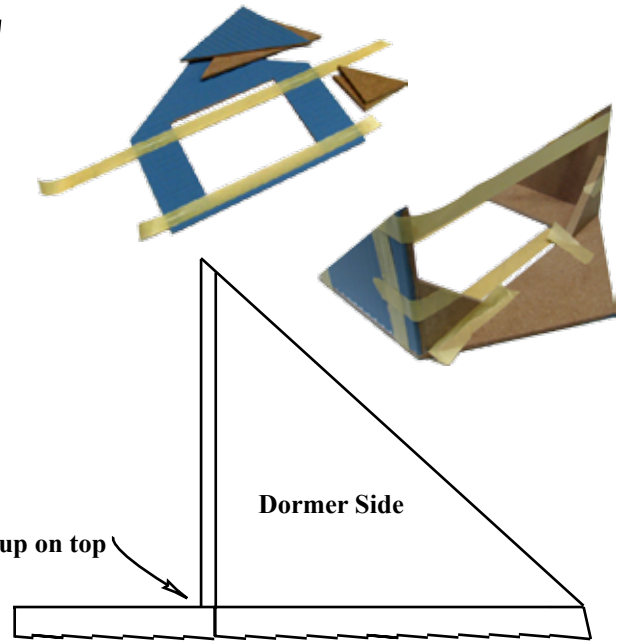

Wiring? Now is the easiest time to lay a "main loop" with ends that go into the Foundation.

Everything that you attach to the house assembly from now on should be fully painted (except for texture paint... that will be applied in steps 12 - 14)

11. Glue, tape, and weight the Housebody to the Foundation and Porch Floor, spaced evenly side-to-side.

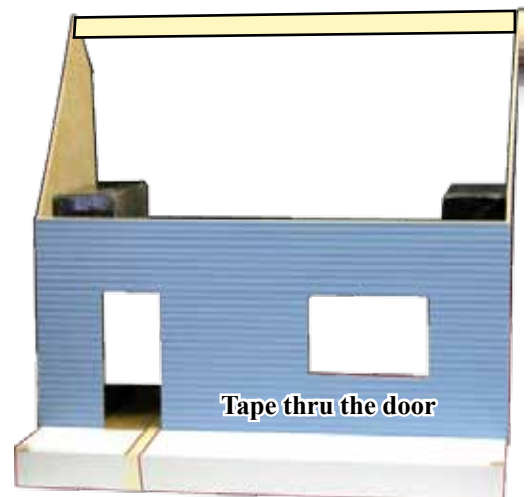
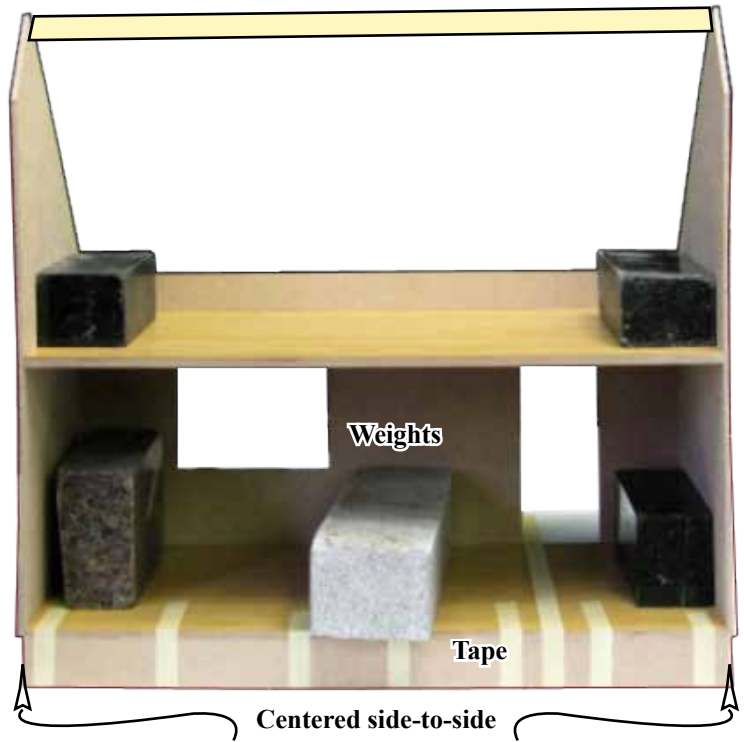

Assemble the Porch: These instructions are customized for stucco/texture paint. The Foundation, the Postbases, and the Step are painted with one coat only of the paint color with no texture additive, and they are sanded. The Rails, the Post sets, the Arches, and the Porch Beam are painted with two coats. Stucco/texture paint is mixed and ready. Without glue, set up the Porch parts. You may wish to lift the Rails with some shingles.

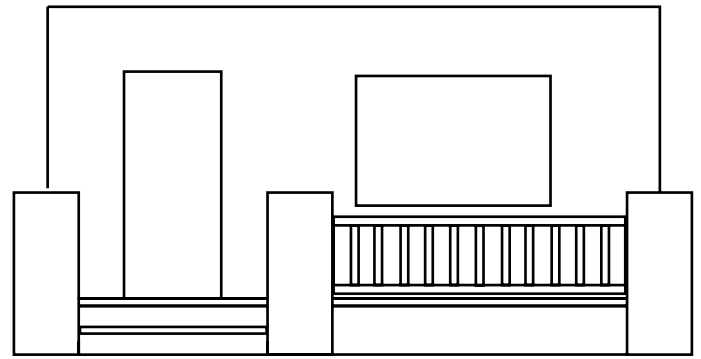

12. Set the Front Step between the Postbases. Set the Tread in place up-side-down (to “mask” the place on the foundation where it will be glued); Texture paint the Foundation above the Steps - avoid the edge of the Base Floor - trim will attach there after everything else is done (keeping the texture paint away from an edge is possible because the first-coat is the same color, so the texture paint only has to *approach* the edge). Now there is texture paint on the Foundation where it will be visible, and there is no texture paint where the Step or Postbases will glue. Clean off the bottom of the Tread. Do not glue the Step to the Foundation yet.

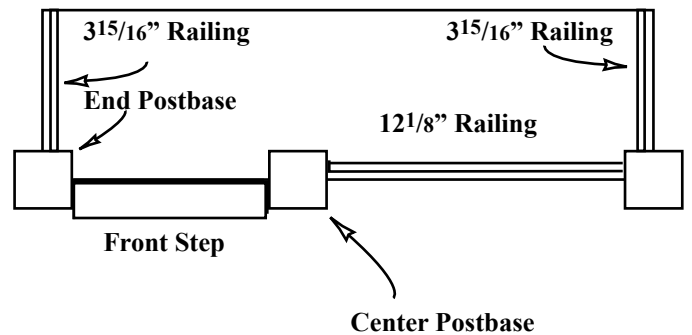

13. On the Left end, glue the 3 15/16” Railing in place about 1/8” from the edge of the floor (and lifted with pairs of shingles if desired). Put glue on both ends of the Railing. Put the Postbase in place so it touches the Railing and gets a dot of glue from each rail. Texture paint the back and right side of the Postbase but do not texture paint where the glue dots are... the grit in the texture paint will interfere with the rail’s glue joint. (You are putting texture paint in places that will be next to other colors for a clean paint-line, and you are not texture painting the left or front edges so you can put the Handy Square and Porch Beam against the Postbase to straighten it... you will paint those surfaces after the glue dries). Glue the Postbase to the Foundation, Porch Floor, and Railing. Straighten the Postbase with Handy Squares and the Porch Beam. Check that the Railing is straight. Let the glue dry.

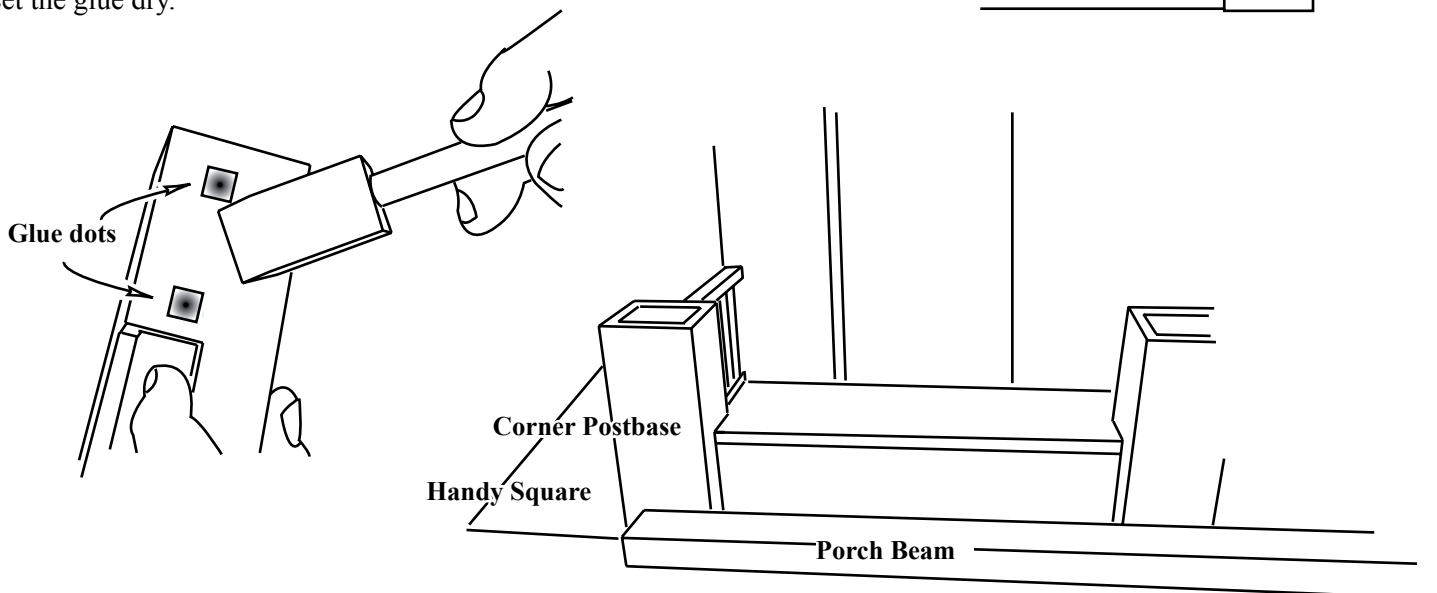
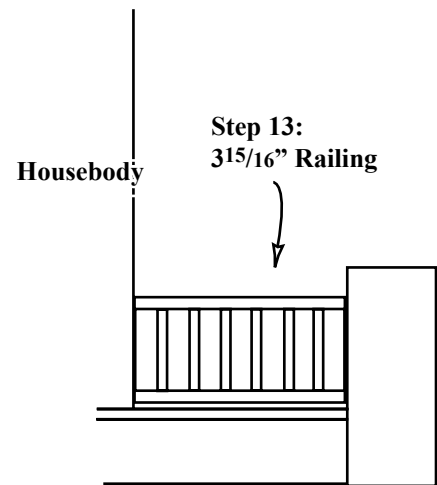

□ 14. Repeat the glue-dot, paint, and glue process for the other side of the porch. Do the “glue-dot” routine with the Front Railing and the Side Railing at the same time. Mark, Texture-paint, and glue both Postbases in place.

Straighten the Postbases with Handy Squares and the Porch Beam. Make sure the Postbases are tight on the Railings, tight on the Porch, straight, and square.

Straighten the Railings.

Let the glue dry.

Finish painting the Postbases and Foundation.

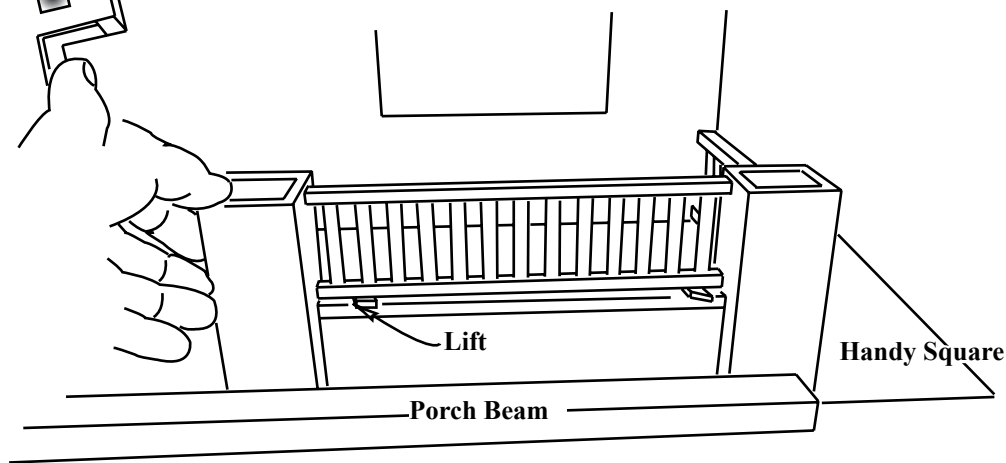
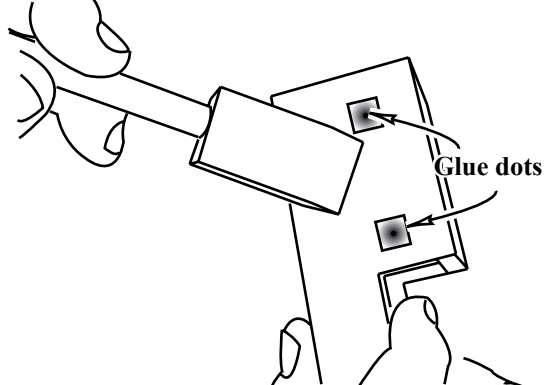
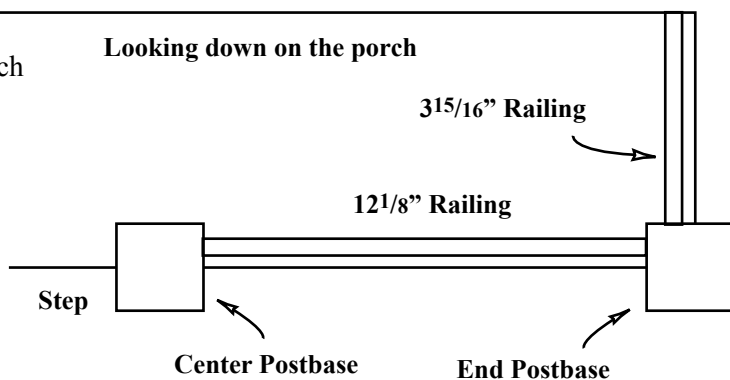

□ 15. Glue a Postbase Cap to the Center Postbase, centered.

Glue Post assemblies to the corner Postbases, centered and straight. Aim the notches for the arches toward each other (toward the center).

Glue the Porch Beam to the Postcaps, lined up with the Posts.

Inspect the Posts carefully and adjust them if necessary to make them straight from the front and from the side.

Step 15:
Side View

Lined up

Note: If the Beam doesn't line up with the Posts front-to-back, the Porch Rafters may not fit

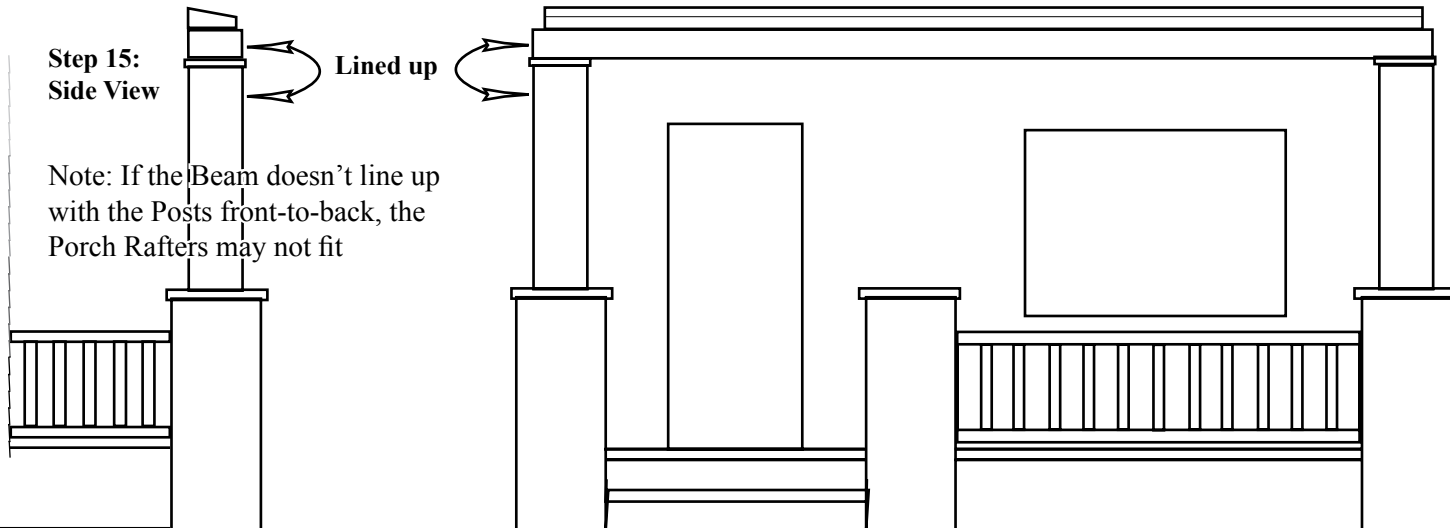

- 16. Cut wide Stripwood ($\frac{3}{32} \times \frac{7}{16}$) for the Side Trim. Hold the Stripwood against the Side, lined up at the back edge and bottom. Use the top of the Side and Front wall as a cutting guide - cut the Stripwood with a fine-tooth saw (like the X-Axto razor saw) Save the cutoffs for Dormer Trim
Cut a Side Trim pair for the other side too. Glue and tape the Trim to the Sides

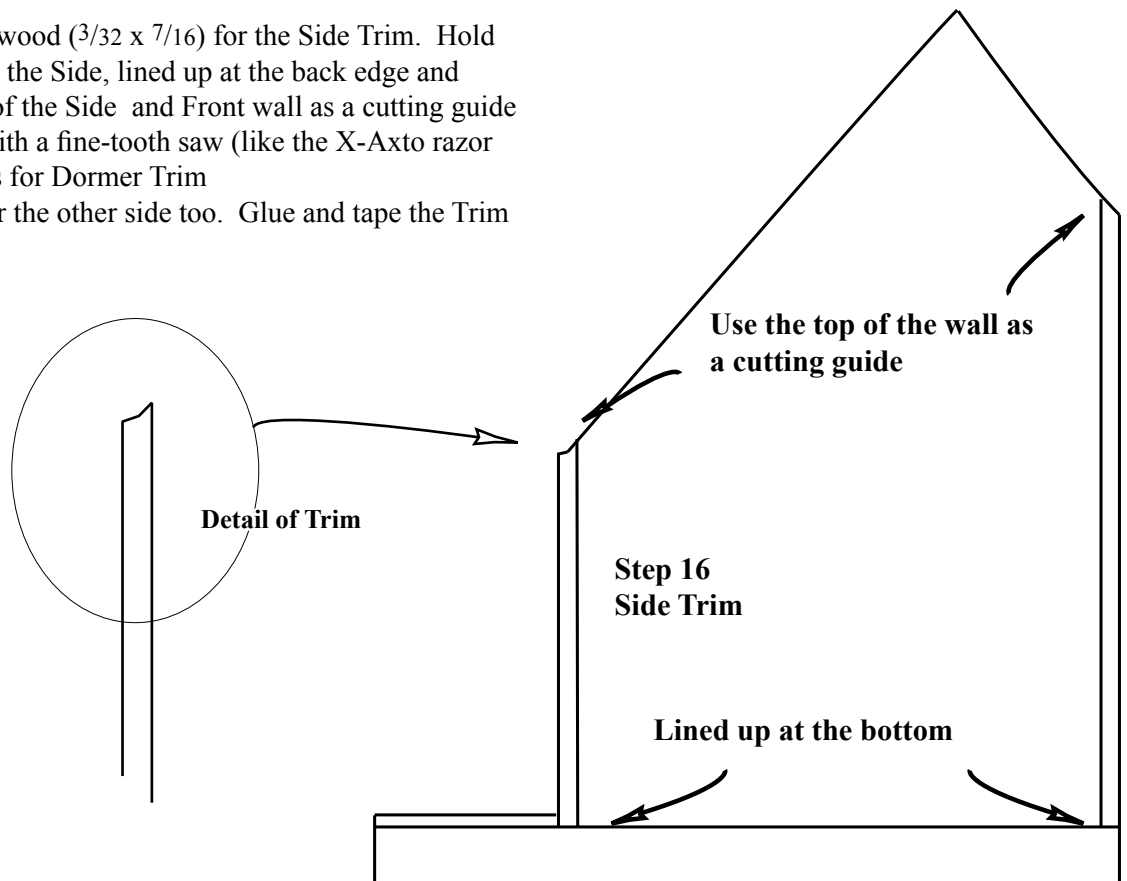

- 17. Glue and tape the Rear Roof to the Sides and Attic Ceiling, lined up at the top and centered side-to-side ($1\frac{1}{2}$ " overhang).

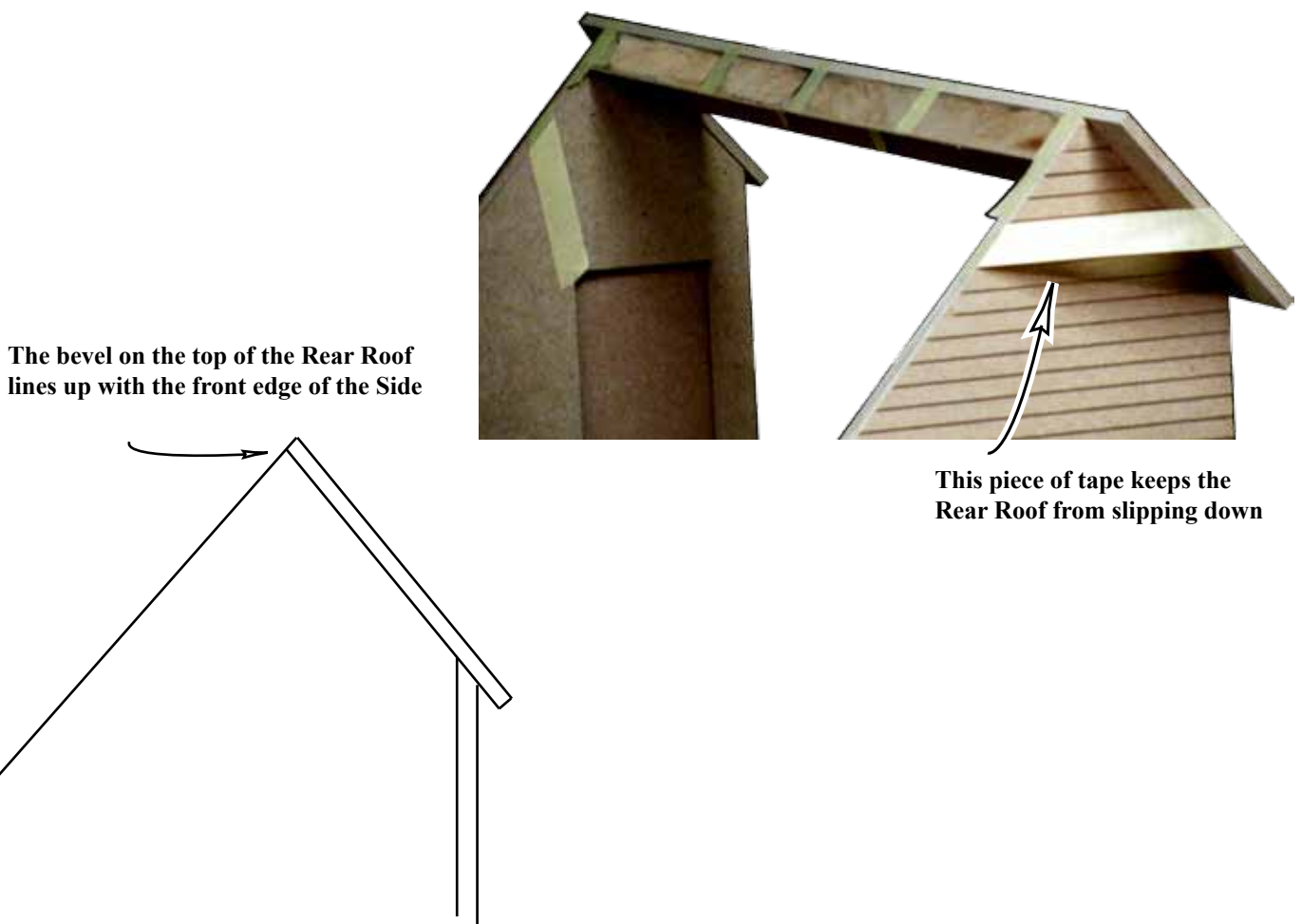

18. Lay out the Front Roof and Porch Roof up-side-down. Tape them together with the points of the bevels touching. Turn them over and spread glue in the bevel where they touch. Without glue, set the Front and Rear Roof on the housebody. Tape over the top and thru the dormer cutout to hold the parts in position as the glue dries.

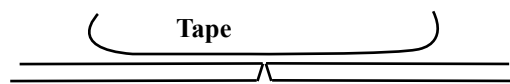

**Step 18: up-side-down
The points of the Bevels
are touching**

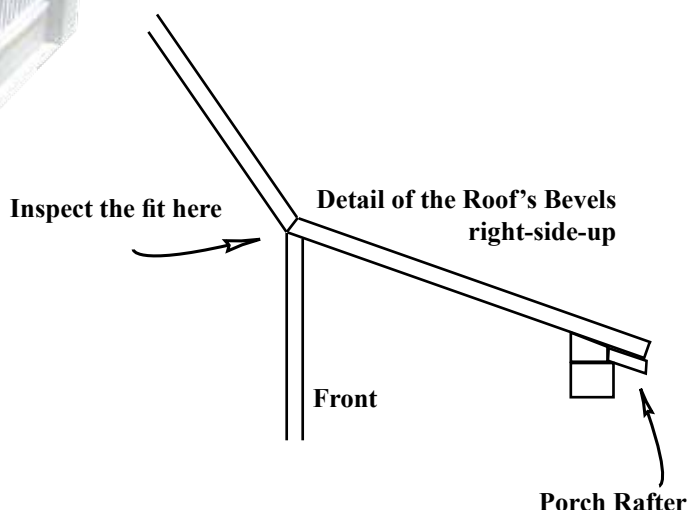

19. When the glue is dry, remove the Roofs and take off the tape; spread glue on the housebody and Porch Beam where the Roofs touched, and glue the Roofs back in place. Inspect the fit side-to-side (1 1/2"), and make sure the Roofs make a good fit with the Front Wall inside the Dormer hole.

Check the Porch Beam's position by holding a Porch Rafter against it on both ends.

The Rafters must fit the edge of the Porch Roof the same on both ends (they do not have to line up with the edge - they do have to fit the same).

**Step 19: Porch Rafters
fit the same on both ends**

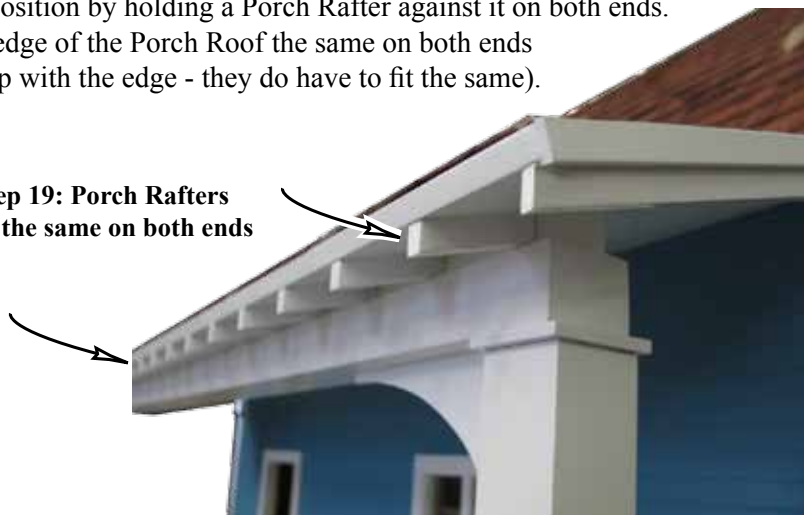

20. Glue and tape the Dormer to the house, lined up on the inside of the cutout.

21. Cut Dormer Vertical Trim for the Dormer. Use $\frac{3}{32} \times \frac{5}{16}$ Stripwood for the side trim, and left overs of the $\frac{3}{32} \times \frac{7}{16}$ Stripwood used on the Side Vertical Trim for the front. Cut the Side Trim first, then the Front Trim. Leave a gap at the bottom for shingles (2 thicknesses of shingles) so you won't have to cut the shingles to go around the Trim.

Glue and tape the Trim in place.

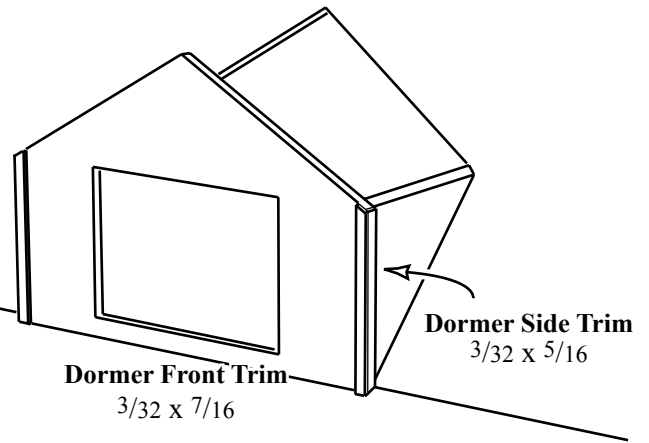

22. Tape together the Dormer Roofs at the peak. Test them in place on the Dormer, and mark the position on the Front Roof. Glue and tape the Dormer Roofs to the Dormer and Front Roof.

Step 22: Dormer Roofs

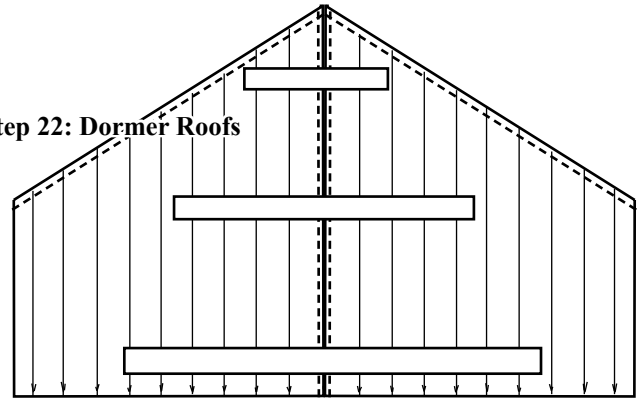

Mark the position

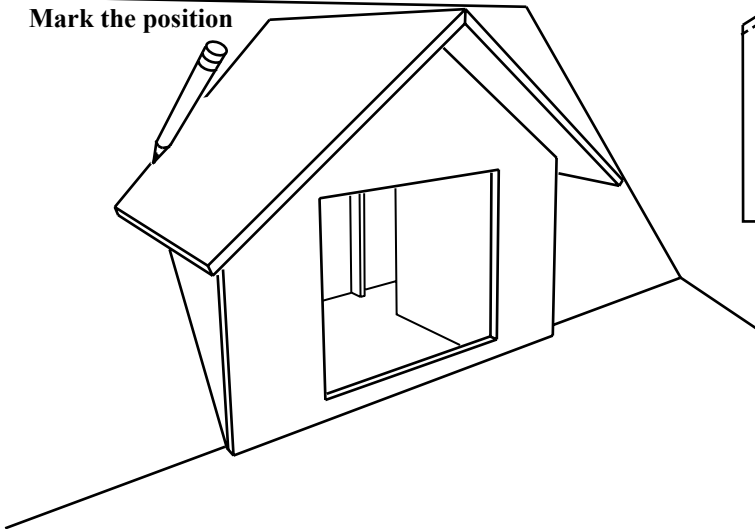

"Down-pressure" tape

Attic Dividers taped together and to the roof

"Down-pressure" tape

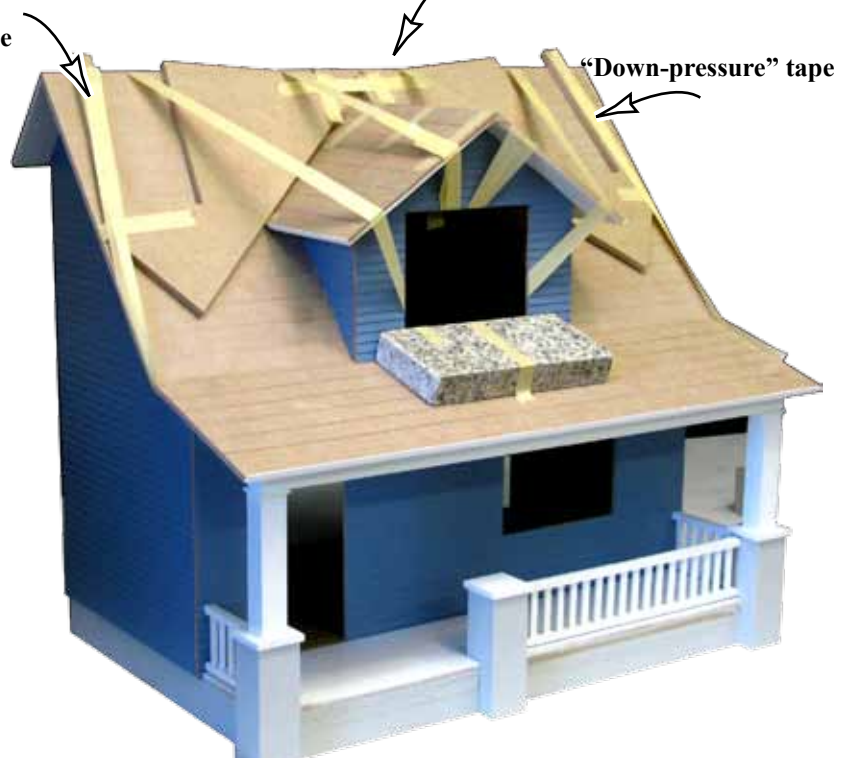

Builder's note: It's always hard getting down-pressure on the back edge of the Dormer Roof. Sometimes I tape weights to the Dormer Roofs; this time I taped two Attic Dividers together and hung them over the Dormer Roofs, then taped them to the roof. After the Front edge of the Dormer Roof was taped down, I looked under the Dormer Roof's overhang, and could see how much down pressure was needed to get contact at the top of the Dormer Side. I pulled down on the outside of the Attic Dividers with long flaps of tape on the left and right evenly until the fit was good.

⇒ **Brackets**

The easiest and strongest bracket construction is with first-coated parts that have been sanded.

☐ 23. Arrange a backstop that makes a right angle (90°) with the work surface. Protect the work surface with waxed paper. Glue together 14 Bracket Bases and Struts. Clean up the glue excess (a paint brush and cup of water); let the glue dry.

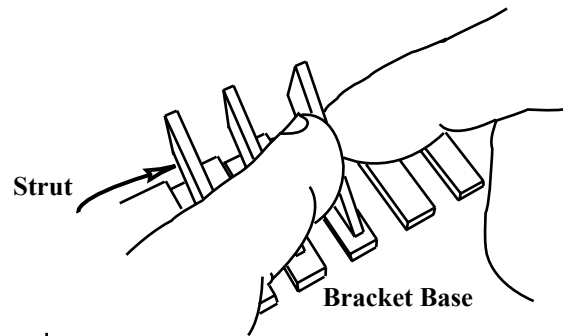

☐ 24. Glue a Bracket Cap to each Bracket Base/Strut. Make:
 5) 49° Brackets Left (flat is on top)
 5) 49° Brackets Right (flat is on top)
 2) 35° Brackets Left (flat is on the left)
 2) 35° Brackets Right (flat is on the right)

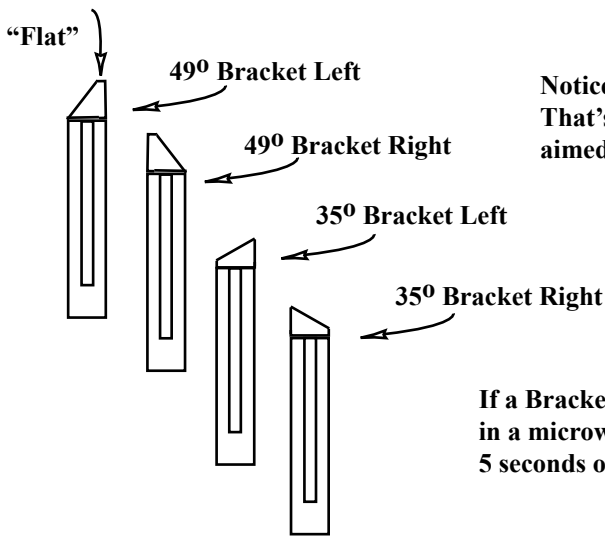
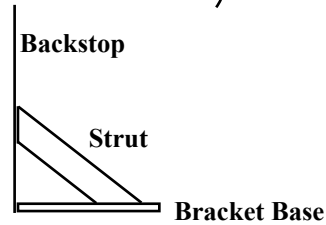

Notice the “flats” on the Bracket Caps. That’s the way you’ll know they are aimed the right direction

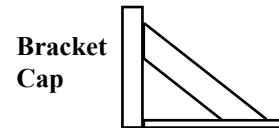

If a Bracket needs a little adjustment to straighten it, a few seconds in a microwave will warm and soften the glue. 5 seconds or so... too much heat will scorch the paint.

Window Assembly:

www.realgoodtoys.help has more window assembly photos

⇒ ☐ 25. Glue and tape together the window frame sets. Turn the frames over and stretch a rubber band around the lip on the inside. Make:

- 1) frame using 6” and 5” Window Frames
- 1) frame using 6” and 4” Window Frames

Turn the Window Frame sets back over, and glue Middle Frames into each window. Space the Middle Frames using the 1 1/2” Spacer.

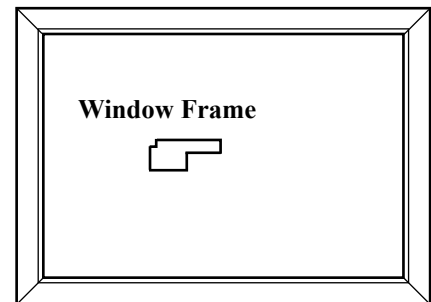

Temporary use of the Spacer to locate the Middle Frames

☐ 26. Glue and tape together Interior Trim. Window Panes and interior trim will be installed as part of the Interior Finishing Plan (see the page 26).

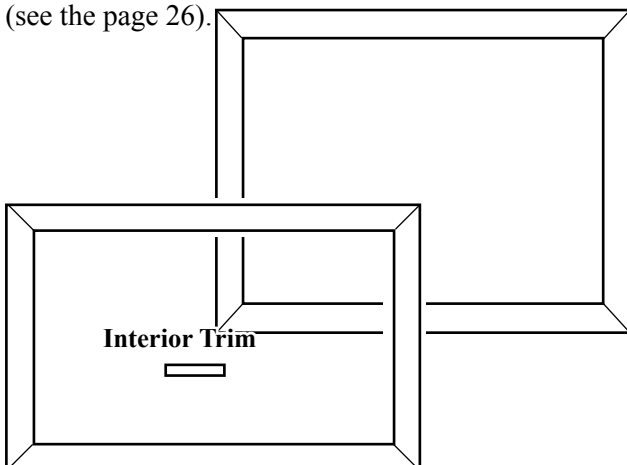
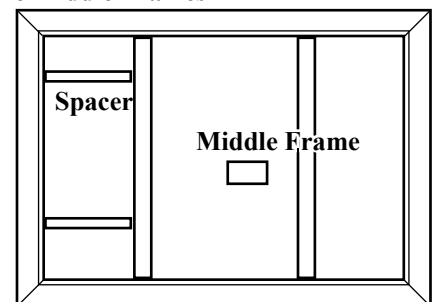

This is a cross-section from the top of how the windows will be installed

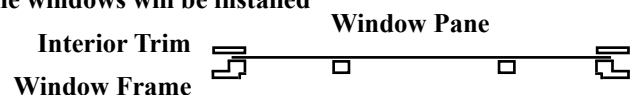

- ⇒ 27. Pull the bottom hinge pin to disassemble the door for painting. Tape the pins under the threshold so you don't lose them (a cut off of a paper clip can substitute for a lost pin). Re-assemble the door when the painting is done. Glue in the pane with a tiny dot of super-glue or silicon glue in each corner.



Rafters

Turn the house up-side-down on several thicknesses of cardboard.

- 28A. **Porch Rafter Ends:** Lightly mark the underside of the Porch Roof every 1 1/2" from right to left, then again from left to right. This will give you pairs of marks 3/16" apart for locating the Porch Rafter Ends.

Glue the Porch Rafter Ends to the Roof and edge of the Porch Beam. Use the Handy Square to keep them straight.

Porch Rafter End

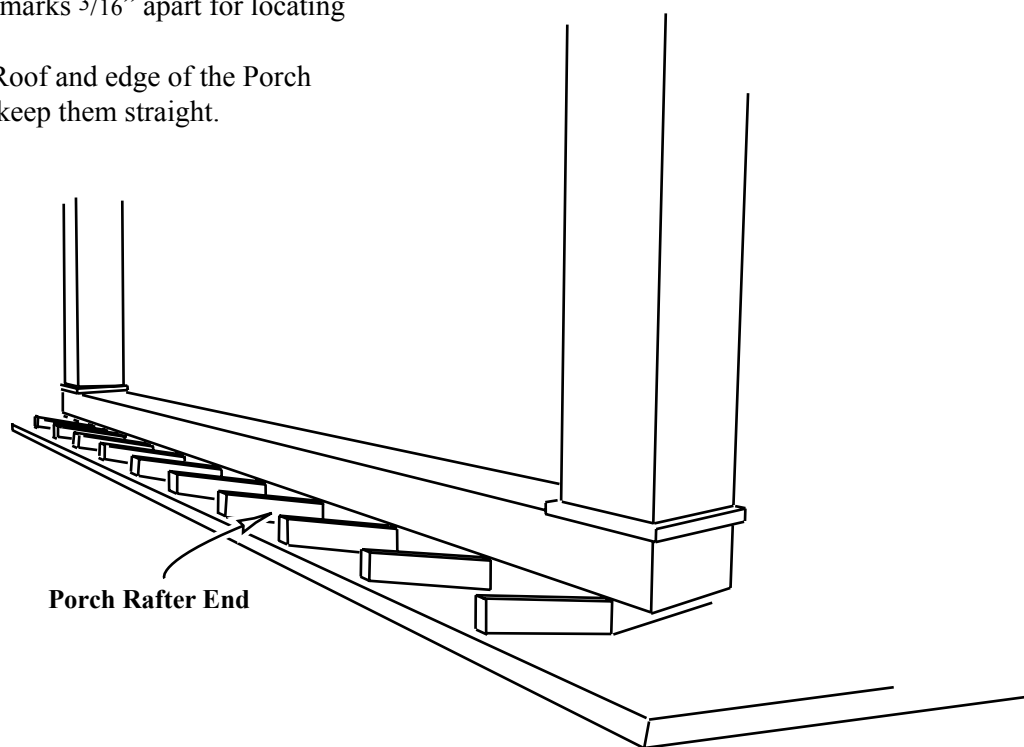

- 28B. **Arches:** Glue Arches to the Posts and Porch Beam, centered front-to-back in the notch.

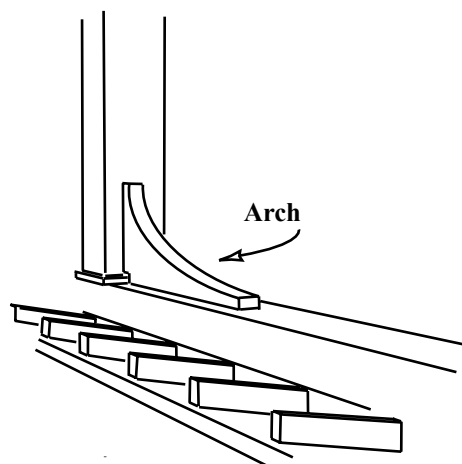

- 29. 49° Side Brackets: A. Glue the rear Bracket to the side and roof, touching the Side Trim at the back edge. Notice the amount of space from the bottom edge of the Bracket to the next clapboard edge. That spacing will be used to place the 2nd bracket.

A. Glue on the rear bracket first

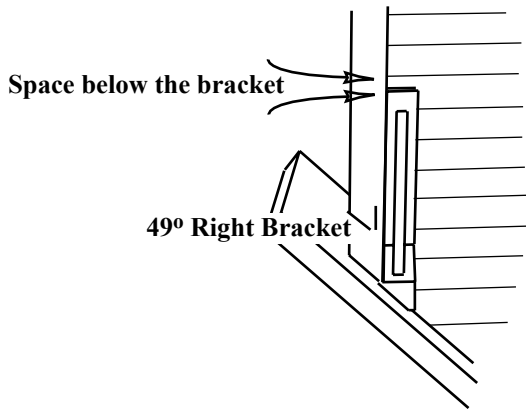

- B. Glue on the second Bracket (notice the Bracket Cap faces the other way) lined up with the first, using the space below the Bracket

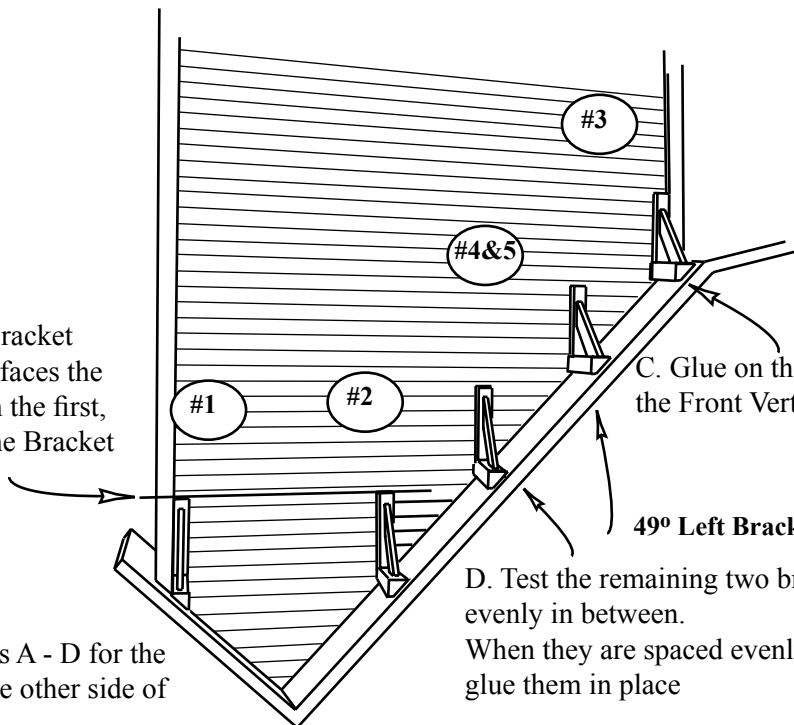

- C. Glue on the third Bracket touching the Front Vertical Trim.

49° Left Brackets

- D. Test the remaining two brackets spaced evenly in between. When they are spaced evenly, glue them in place

- E. Repeat steps A - D for the Brackets on the other side of the house

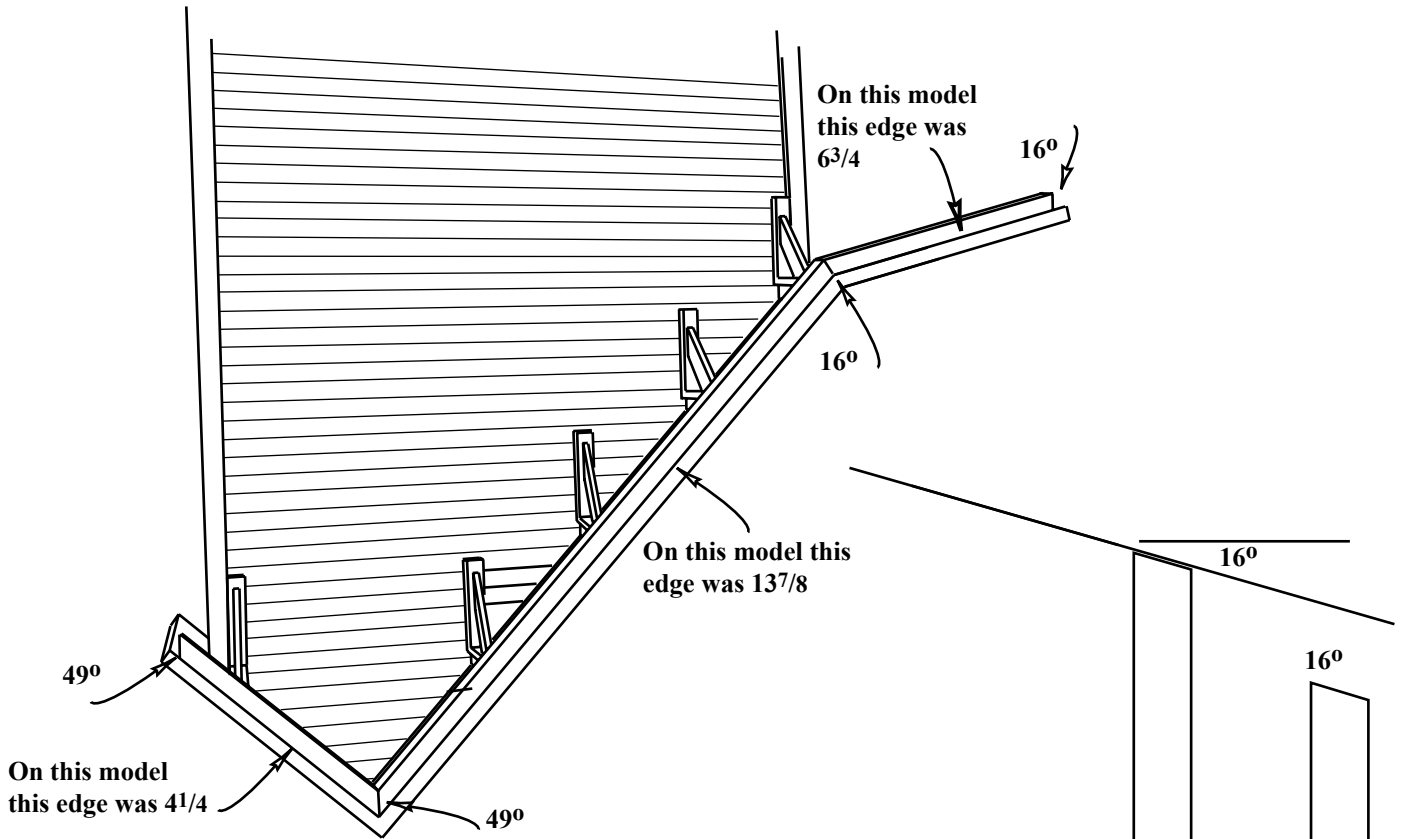

30. **Side Eave Rafter:** Cut Eave Rafters using Rafter Material ($3/16 \times 5/16$). The guide at the right has the right angles, but you must mark the length in place on your house. Use the back of an Attic Divider as a 49° cutting guide. Use the 16° guide on the next page for the 16° angles. (Fine tune the length of the $6\ 3/4$ " Rafter by comparing its end to the Porch Rafter Ends across the front). Glue the Rafters under the edges of the roofs. Repeat for the other side.

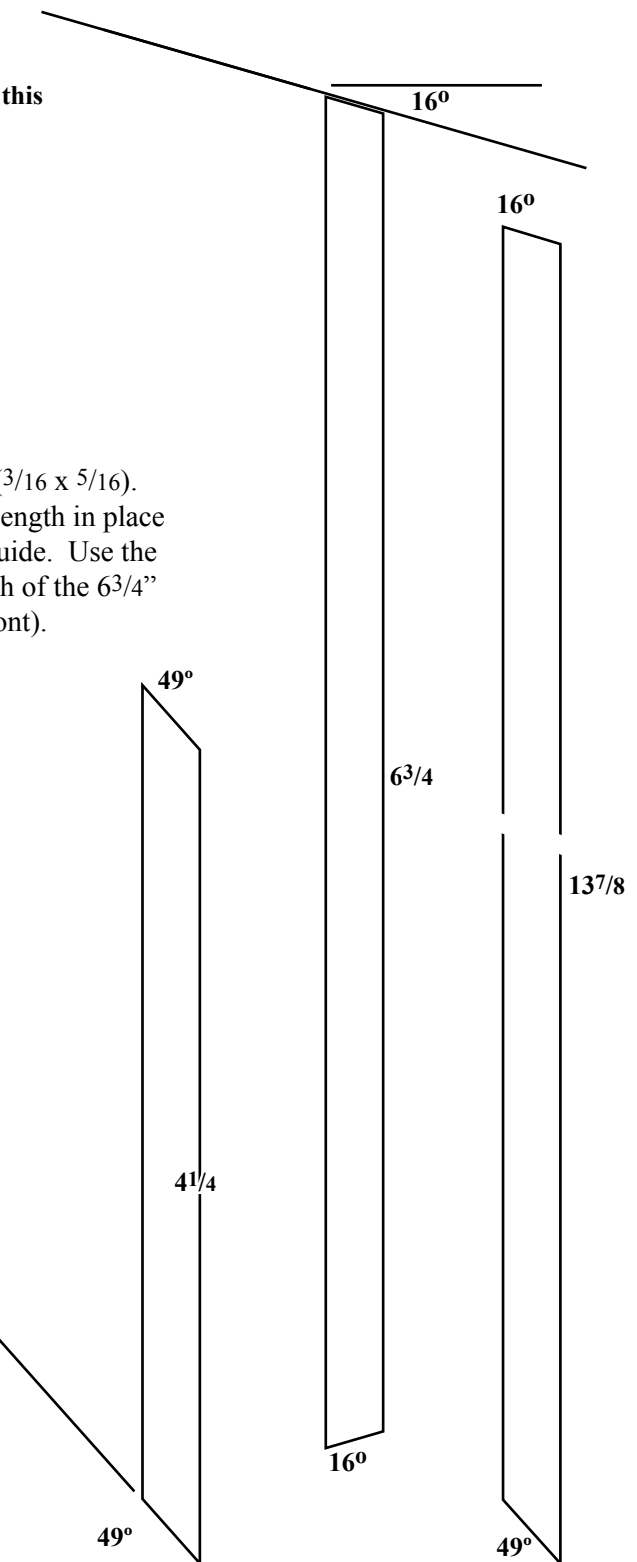

X-acto "Razor Saw" following the cutting angle for Rafters

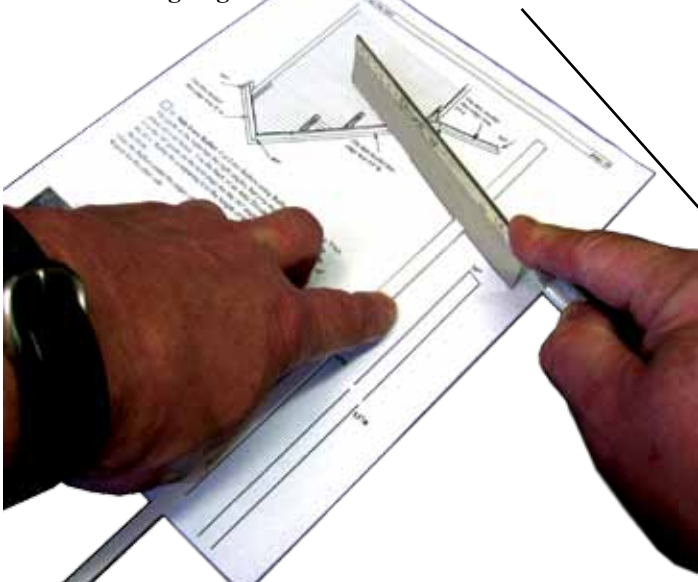

31 A. **35° Dormer Brackets:** Glue the Dormer Window in the Dormer Front.

Glue two 35° Brackets to the Dormer Front and roof, touching the Trim. Glue the other two 35° Brackets centered over the left and right window spaces.

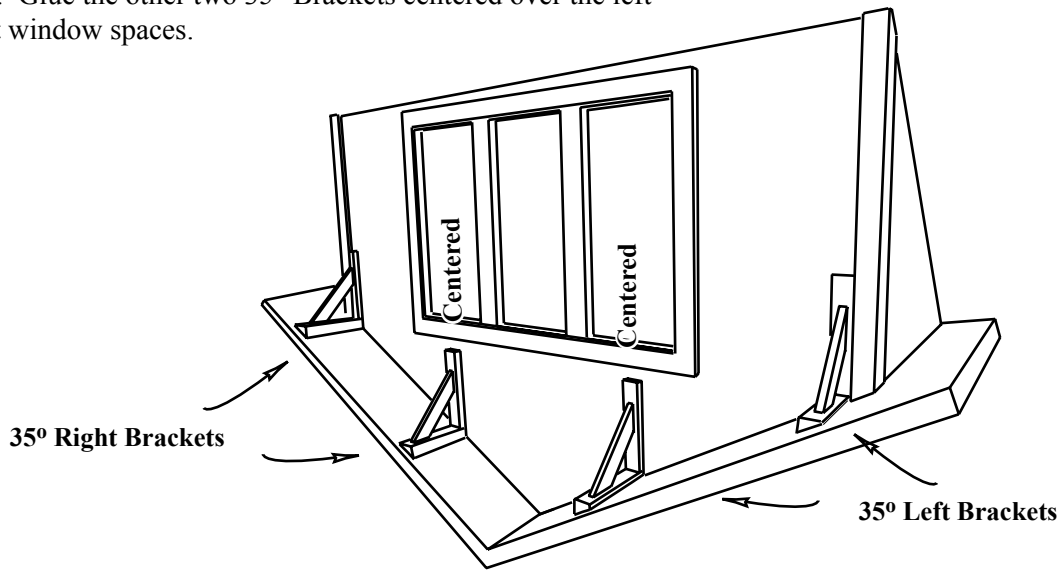

31 B. **35° Dormer Rafter Ends:** Glue three 30° Rafter Ends to the underside of the Dormer Roof, spaced evenly.

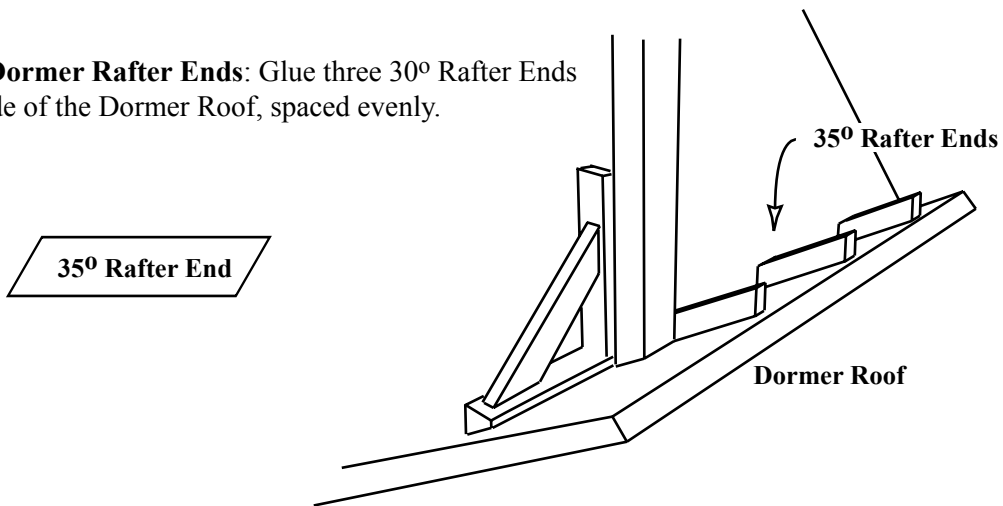

31 C. **Dormer Eave Rafter:** Cut two Eave Rafters using Rafter Material ($3/16 \times 5/16$) see the guide at the right. Glue them under the front edge of the Dormer Roof.

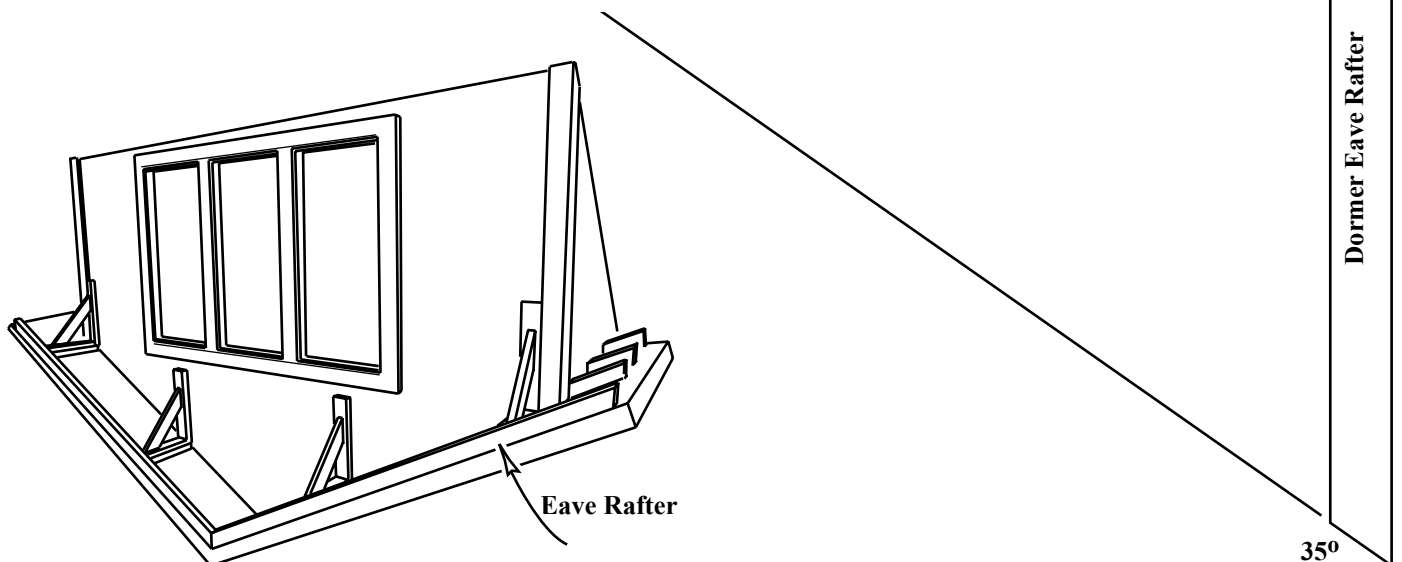

32. **Chimney:** Assemble the Chimneys up side down. Let the glue dry, and paint the Chimneys. Attach the Chimneys 1 1/2" from the edge of the Roof and 2" down from the peak.

see www.realgoodtoys.help for flashing or shingling demos

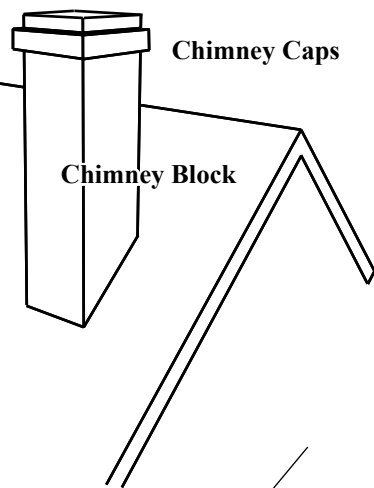

33. **Shingle the Roof:** Glue: Use a thick *solvent-based* (not "water clean-up") panel adhesive available in caulking gun tubes at building supply stores. Trim just a little of the end of the tube for a tiny hole, giving a thin bead of glue. Always use good ventilation with solvent based adhesives. Note: many builders use hot-melt glue for shingling... it does a great job. But the learning process for hot-melt glue always involves burns and lost skin, and I don't suggest it for that reason

A. Cut a "starter course" of Shingles the length from the bottom edge of the Roof to the first Guideline. Glue on the Starter Course lined up with the bottom edge of the Roof.

B. Valleys: Hold a shingle close to a valley and straight up-and-down the roof. Lay a piece of strip-wood in the valley across the shingle to get the angle of the valley. Mark and cut the shingle. Use that shingle to cut shingles for that edge of the valley.

C. Apply a thin line of adhesive just below the lowest guideline all the way across one roof. Press the top edge of a Shingle into the line of glue, squeezing out the excess. Hold the first Shingle and press another Shingle into the adhesive, tight to the first. Hold the next Shingle and press in another... etc. all the way across the roof, cutting the last Shingle to fit

Continue up the roof one row at a time. Start the next row with a half Shingle so that the seam between Shingles weaves back and forth as you go up the roof. Line up the top edge of each row (except the starters) with the guidelines.

Cut the top row of Shingles (1") so that each row will have the same reveal.

D. Finish the top edge with a "Boston Lap": pairs of Shingles laid horizontally. Start at the ends of the peak, and, with each pair overlapping the previous pair, work to the middle.

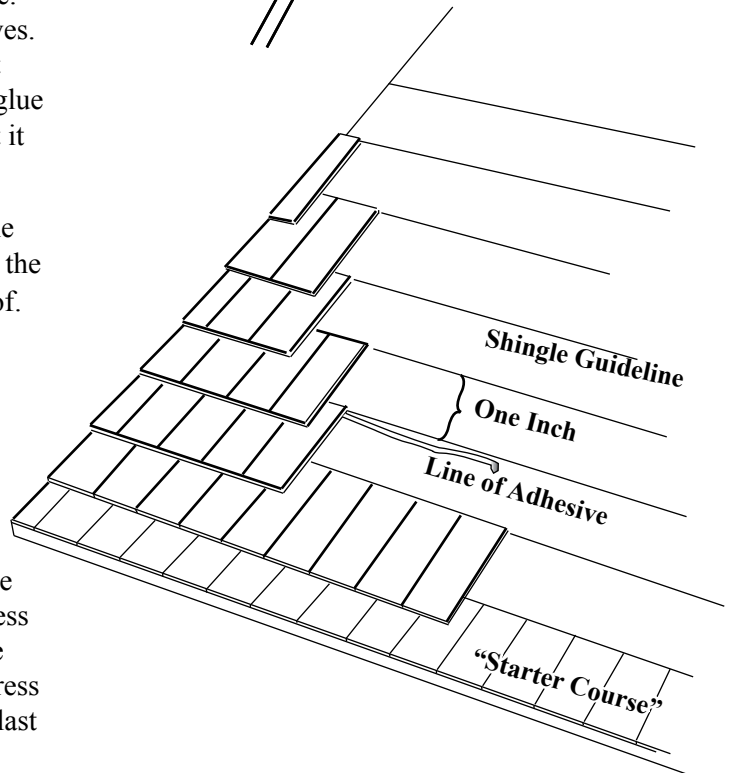

Valley Shingle
Cut with a saw to get two Valley Shingles from one flat Shingle (cutting with scissors splits one shingle of the pair)

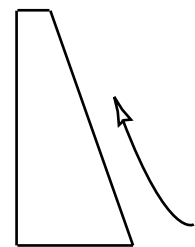

The angle of the valley shingle for each roof is different

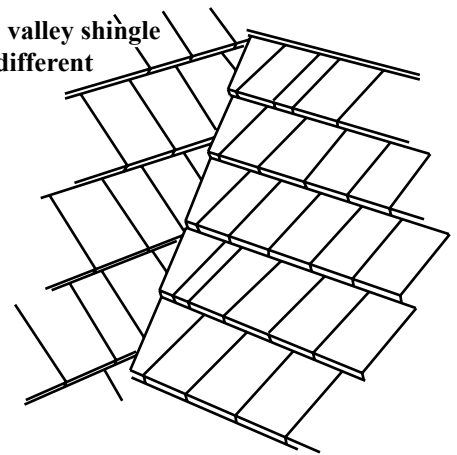
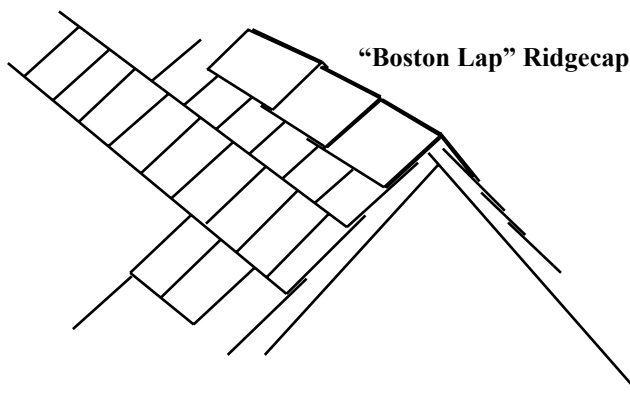

Finish the Outside

34. Install the Door and Exterior Window Frames
35. **Finish the Trim (cut the long pieces first, and the short pieces from the ends:**
Cut and attach Eave Trim ($3/32 \times 5/16$). The Eave Trim uses the same angles as the Rafters (but not the same lengths); it attaches to the edge of the Roofs lined up at the bottom.
Cut and attach trim around the edge of the Porch.
36. Glue on the Front Step and Tread

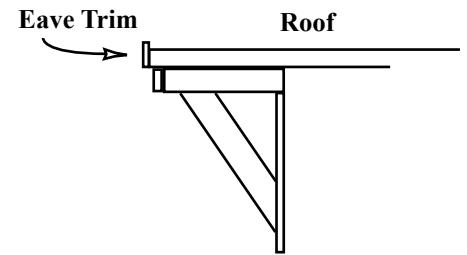

Eave Trim



Trim the edge of the Porch

Front Step and Tread

Finish the Inside...Plan Ahead!

Interior finishing involves so many choices! Will this house be a play-house or a display for miniatures? What accessories will be used and where will they go? Wiring? Banister and Landing Rails? Wallpaper? Tile or carpeting? Every choice makes a difference in the order of finishing. Real Good Toys has provided materials for some basic interior work, but you may choose to do it differently.

- Make your choices
- Get your materials
- Test your layout

With the pieces in your hands, imagine the steps to get to where you want to be.

Now you're ready for **your** order of interior finishing. Here's the order that our assembly pro follows for tackling most custom interior finishing:

- Dividers
- Electrical wiring (using "tape" style wiring)
- Wallpaper
- Interior Window Trim
- Flooring
- Stairs
- Baseboard and crown moldings

□ 34. Lay out the Dividers without glue... straight front-to-back and up-and-down; use a Divider or Attic Divider as a square for positioning a Divider; mark its location, then switch - using the second Divider to mark the first's position, until they are all marked. To glue Dividers in, apply glue, tip the Divider and put it almost all the way in, set the base, lift the floor or roof above for some clearance, tip the Divider upright, and slide it the rest of the way in place, clean-up the excess glue.

□ 35. Set the Window Panes in the cutouts. Glue and tape the Interior Frames to the wall. Look inside the window to line up the inside edge of the interior frame with the inside edge of the outside frame.

Glue and tape the Door Interior Trim to the door and the wall.

⇒ □ 36. Glue and tape together the Top and the Bottom Stair Blocks. Let the glue dry. Glue the Stairs to the floor and wall, lined up with the Mid Floor's top. Test the Stringer on the edge of the Stairs, lined up at the bottom. Mark, then cut the Stringer. Glue the Stringer to the Stairs.

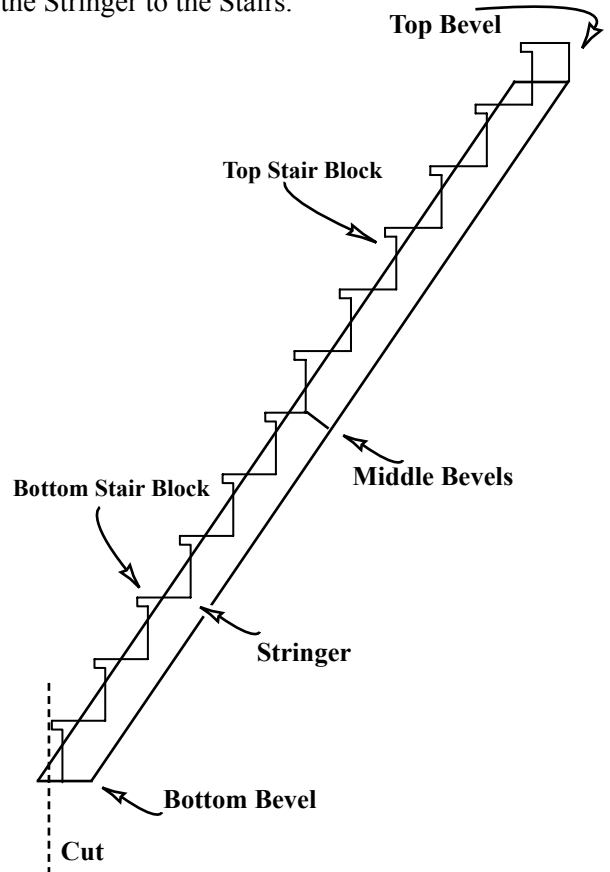

That's it! You're done with the House Assembly part of your dollhouse project.

Have fun with the rest!

Cut and tape together
the layout diagram for
the 12¹/₈" Railing

Cut

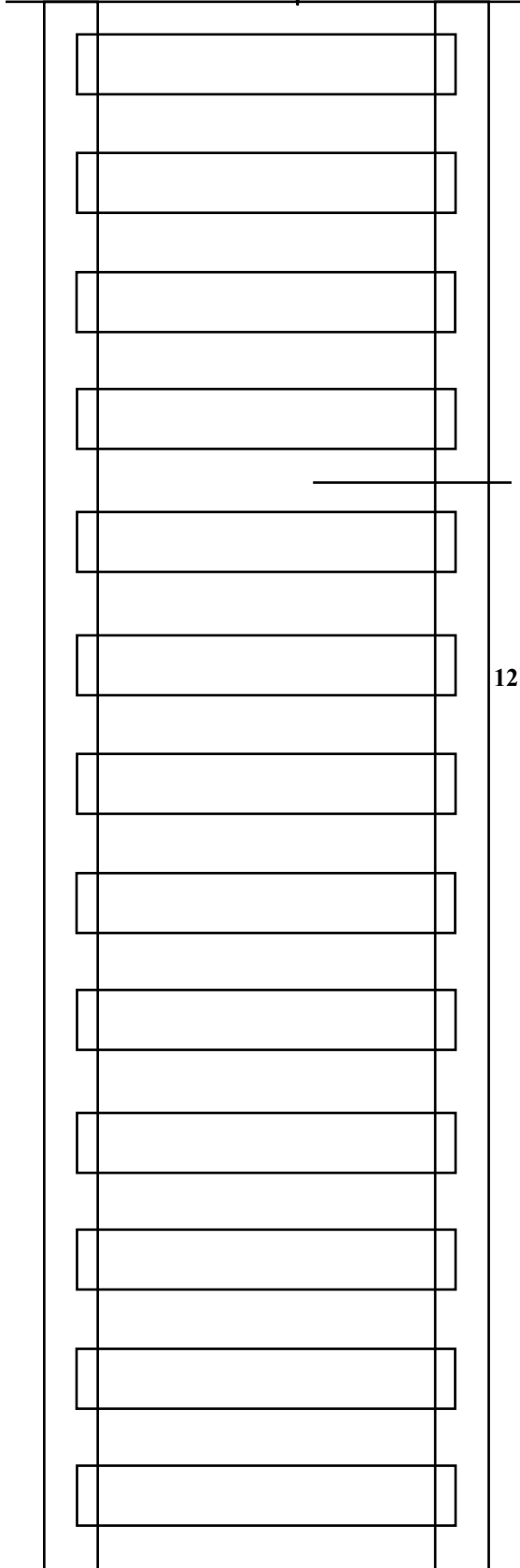

1" Spacing for Shingle Guidelines

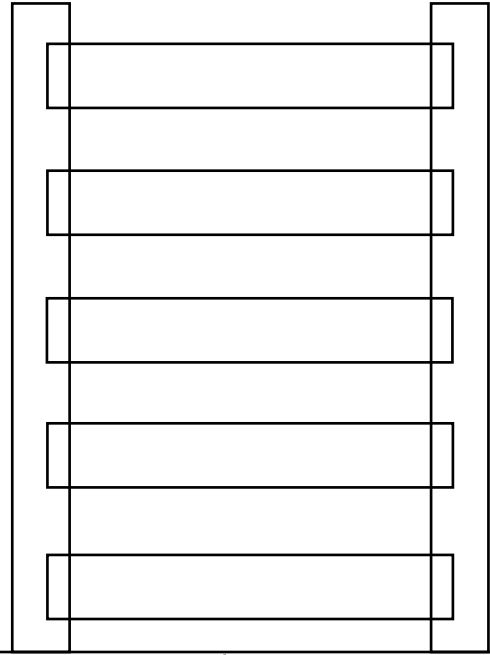

Cut

Editor's Note: Two printers never print exactly
same size... If this illustration is close to the
length of your Rails, center the rails on the
Illustration. If not, space 18 Balusters evenly
using another Baluster to lay out the spacing.

12¹/₈

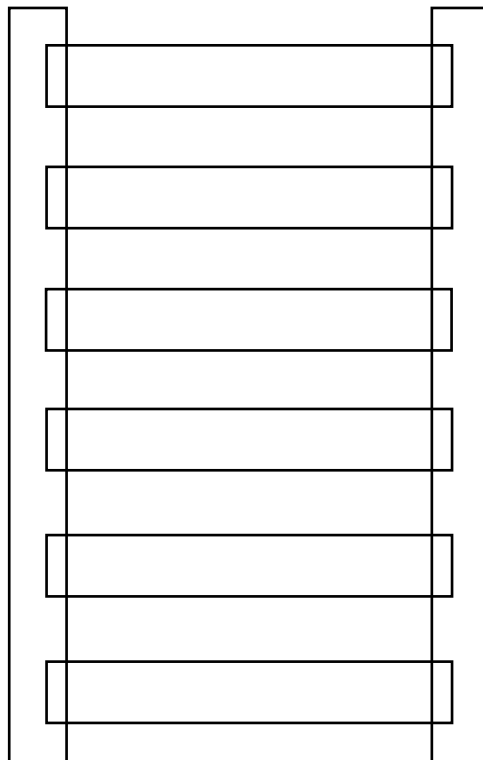

3¹⁵/₁₆

1" Spacing for Shingle Guidelines