

Direct from the "Margaret Woodbury Strong Museum"..

When the world's finest dollhouse museum decided to put their name — and stake their reputation — on a dollhouse kit, they came to Real Good Toys, the oldest manufacturer of quality dollhouses in the country!

Working together, we created the most magnificent Victorian Dollhouse available anywhere! THE ELLWANGER HOUSE, a replica of an historic Rochester, New York mansion. It's all wood, 3/8" construction, covered with gingerbread; it includes wraparound porch, bay window, stairs, porch columns, all windows and door trim and hardware. It's 4' long X 3' high X 21 1/2" deep with 12 rooms! The window openings are cut to accept standard components and there is a finishing kit available.

October 12, 1982 is the Grand Opening of the Strong Museum. This opening will be covered by all the leading miniature magazines and will appear in the media frequently thereafter.

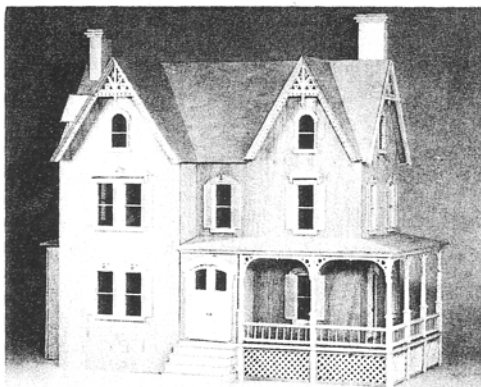

It will be the No. 1 attraction for miniaturists, and it's name will be synonymous with THE VERY BEST! Carry the VERY BEST ... carry The Ellwanger House from the Margaret Woodbury Strong Museum and Real Good Toys.



Box 706
Montpelier, VT 05602
(802) 479-2217

Real Good Toys

Available on a Limited Basis in 1982... wholesale price \$215

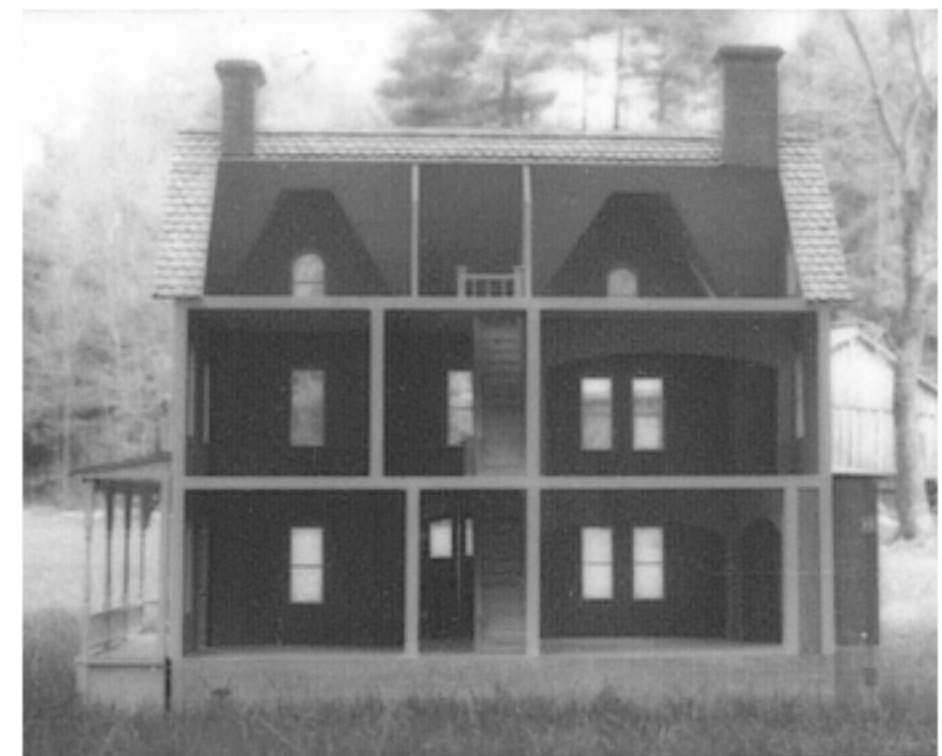
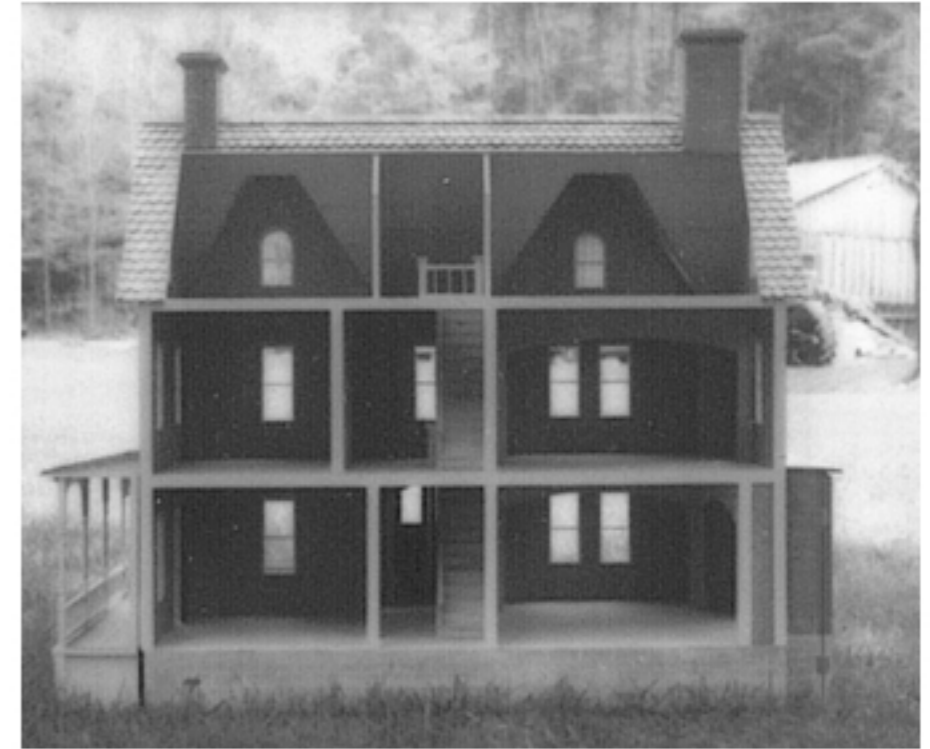
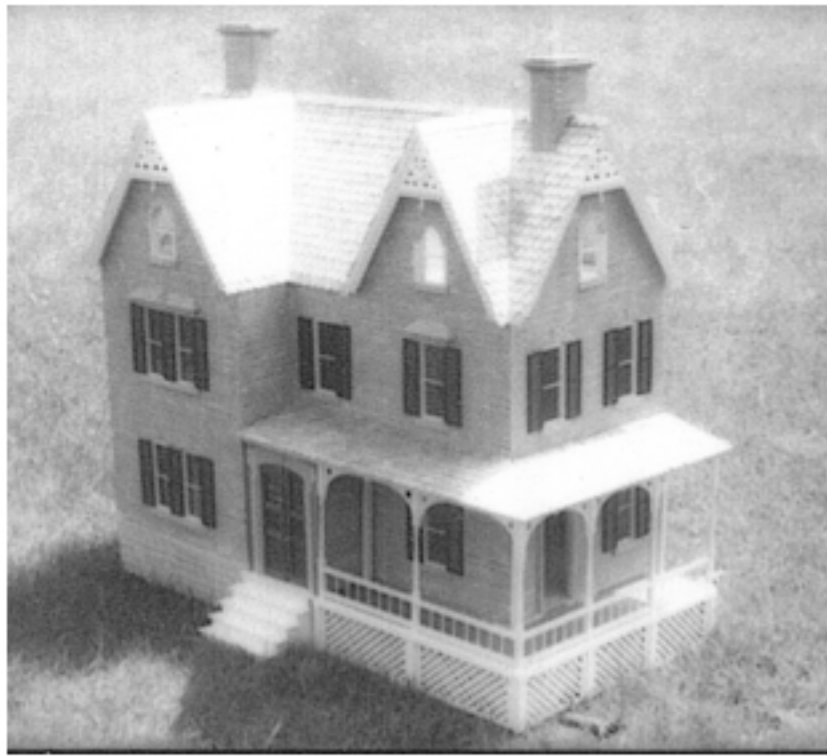

PARTS LIST OF PACKS

#1 Stairs
2 stair backs
26 stair treads

#2 Stair balcony
15 1/8" dowels
4 long rails
2 short rails
5 posts
5 post caps

#3 Bannister
2 stair sides
1 long bannister
1 short bannister

#4 Int. wind. trim
28 wind. verticals
23 wind. horizont.

#5 Inside wind. mold.
28 wind. verticals
14 window tops
28 1/8" strips
14 window mullions

#6 windows
14 plexi windows

#7 - finish. kit
extra window verts

#8 single wind. trim
5 single wind. arches
5 keystones
5 1/8" trim pieces
5 bottom horiz.

#9 - double wind. tm.
2 left arches
2 right arches
2 ctr. triangles
2 keystones
2 window horiz.
2 1/8" trim pieces

#10 - 24 shutters

#11 - angled wind. top and trim
4 long window horiz.
2 short wind. Horiz.
2 long wind. tops
1 short wind. top
2 decorative triangles
2 1/8" short trim pce.
1 1/8" longer trim pce.

#12 Front door trim
1 exter. arch trim
1 inter. arch trim
2 exter. vert trim
2 inter. vert trim
1 keystone
2 side inter. strip
2 top inter. strip

#13 Front door
2 windows
2 large panels
2 small panels
2 angled door sides
2 long door sides
2 arched moldings
2 single-grooved
1 small molding
2 double-grooved
1 small molding
1 center door strip

#14 Hinges and Knobs
6 small hinges
2 large hinges
3 door knobs
24 small nails
8 screws

#15 Gable window trim
8 exterior arches
8 interior arches
16 window verticals
8 interior verts.
8 1/8" bottom strips
8 bottom horiz. pces.

#16 Side door and trim
1 side door
1 exterior trim arch
2 exterior vert. trim
2 interior vert. trim
1 interior horiz. trim

#17 Gable gingerbread
8 vert. "holy" pieces
4 horiz. "holy" pieces

#18 Gable ledge molding
2 sets (left and right) of long moldings
1 set medium moldings
1 set short moldings
1 set dormer moldings

#19 Peak gable qingrbd.
4 triangles
4 "arrows"
4 sets triangle trim
8 circles (lge)
4 center pieces
4 bummy pieces

#20 - peak chimney
2 notched sides
2 ends
2 wide trim strips (long)
2 " " " (short)
2 narrow " " (long)
2 " " " (short)

#21 - sloped chimney
2 slanted ends
2 sides
2 wide trim strp. (long)
2 " " " (short)
2 narrow " " (long)
2 " " " (short)

#22 Entryway stairs
2 side pieces
5 treads
4 regular risers
1 bottom riser
1 rear piece

#23 - Dormer
1 front
2 sides
2 roof pieces

#24 - Dormer window tri
1 exter. arch
1 inter. arch
2 thin inside arches
2 exter. verticals
2 bottom horiz. trim
1 window sill
2 inside verticals
1 horiz. peak trim
1 vert. peak trim
1 exter. wind. horiz.

#25 - gable, dormer win
4 gable windows
1 dormers window

#26 - bay window triang
2 center triangles
2 side triangles

Porch moldings
A. long molding
B. short molding

C. Lattice work
4 lattice frame pieces
5/16" X 7 9/16"
10 lat. frame pieces
3 5/8" X 1/2"
6 lat. frame piece

5 1/2" X 5/16"
38 lat. pces 1/4 X 5 1/2"
20 " " 4 5/8"
20 " " 3 5/8"
20 " " 2 5/8"
20 " " 1 5/8"

D - Pine supports
2 1-grooved pce.
1 2-grooved piece
1 corner grooved pce.

E. 4 rear support panels

G. Railings
4 long railings
6 short railings
1/8" dowels

H. Porch gingerbread
3 short pces
2 long pces

J. - Porch triangles
3 regular triangles
1 corner triangle

K. Porch columns
1 corner column
2 end columns
3 middle columns
3 rear support col.

L. - Porch edge trim
1 pce. front trim
1 pce side trim

PANELS

F - foundation strip
Base floor
2 additional floors (2nd and 3rd)

Panel #1 - left side
#2 - left side inset
#3 - left front
#4 - left front inset (left)
#5 - left front inset (right)
#6 - right front
#7 - right side
#8 - bay window sides (2)
#9 - bay window front
#10 - entryway front panel
#11 - entryway roof
#12 - entryway side
#13 - 1st flr. arched divider (bay side)
#14 - 1st flr. arched divider (front)
#15 - 2nd flr. arched divider
#16 - 1st flr. long divider
#17 - regular dividers (3)
#18 - rear roof strip
#19 - front roof panel
#20 - rear roof vertical (2)
#21 - left gable left roof panel
#22 - left gable right roof panel
#23 - attic dividers (2)
#24 - right gable left roof panel
#25 - right gable right roof panel
#26 - porch floor
#27 - porch ceiling
#28 - long porch roof
#29 - short porch roof
#30 - rear porch foundation
#31 - Bay window front roof panel
#32 - Bay window ceiling
#33 - Bay window roof sides
#34 - 2" divider (for 1st flr. bay arch)
#35 - front foundation piece

HOW TO ASSEMBLE THE "ELLWANGER HOUSE" DOLLHOUSE

This house is a replica of an historic Rochester, N.Y., Victorian mansion called the "Ellwanger House". Located in the Mount Hope section of the city, it was the residence of one of the one of the most prominent Rochester families at the turn of the century. The Ellwangers were co-founders of one of America's most successful nurseries. The house is now owned by the Landmark Society of Western New York, which is planning to restore it fully. It was selected by the Margaret Woodbury Strong Museum and Real Good Toys for its historic value and because it's a beautiful example of the Gothic Victorian style of American architecture.

Real Good Toys has put together a finishing kit to enable you to make your house look exactly like the original model of the Ellwanger House which is on display at the Margaret Woodbury Strong Museum. It includes bricks, copper flashing, paint, glue, etc. Everything you need. If you are going to use it note: You begin using the finishing kit Before the roof is attached. There is a separate set of instructions for the finishing kit which you will want to read before you put this house together.

If you choose to finish the kit some other way, we recommend that you find a local dealer who sells miniature supplies and work with that dealer. One of the nice features of the miniatures hobby is the amount of personal help you can get in your projects from the specialty shops.

THERE ARE A FEW STANDARD RULES THAT YOU SHOULD FOLLOW. We always tell people these things, but we wonder how many listen. If you pay attention here, you will probably save yourself some trouble later.

1. Read these instructions through before you try to assemble the house. Go ahead and handle the parts as you read it, so familiarize yourself with them, but DON'T GLUE! It's really worth the time.
2. When you actually are ready to assemble, read the whole section of an assembly step through before acting, and THEN do a dry run of each step. It may seem tedious, but sometimes instructions jump around a little bit, and you're much better off knowing the whole series of steps than following each little direction blindly.
3. We assume that you have the standard tools and at least a basic knowledge of how to use them. We've tried to explain any terms that might not be familiar (like "pre-set"), but haven't explained how to hammer or clamp. To assemble this house, all you need is: a hammer, (a tack hammer would also be helpful), a measuring tool (yardstick or tape measure), a straight edge (the yardstick is a good one), a pencil, a screw driver, masking tape, glue, and some nails.

About the glue: We always use Elmer's Glue, so we know that it works. But there are dozens more that people use successfully. We do not advise against any glue that you think works for you, but we do suggest that you use a glue that dries clear. When using glue in areas you are going to stain, be extra careful. Glue tends to ooze out of joints, and when it does it seals the wood, keeping the stain from working. Because of the dripping of the glue, it's a good idea to always have a wet cloth sponge, or paint brush around to wipe the glue off with as you assemble.

About the nails: We have not included any, because we're not sure which to recommend. This is an ongoing argument at Real Good Toys. We always use "panel nails", which are nails with rings on them so they hold extra-well, like screws. They are harder to drive straight than standard nails, however, and if you hit them slightly askew, they snap off and go flying. This makes them a little dangerous, too.

The other alternative is $\frac{1}{4}$ " or 1" finishing nails (the kind that don't have a head), which are easier to use than panel nails but don't hold as well. The choice of which to use is really yours, depending on what you feel most comfortable with. You might find it convenient to have some $\frac{1}{4}$ " 18 gauge nails around too, for the times when a large nail is inappropriate.

Masking tape: At Real Good Toys, we refer to masking tape as a "disposable paper clamp". Really, you'd be amazed at the things that masking tape can be used for in assembling a doll house. Its best feature is the way it holds joints together, or small parts in place while they're gluing. Even when we don't specifically recommend tape, you should think about using it.

Before you plunge into this project, you are of course going to consider how and when you should paint or wallpaper the rooms. We have found that wallpapering is easier when the house is already assembled, but the window trim is not in. That is why we have recommended that the window trim be put in last. It would probably be easier if the doors were not in either. However, that would be too difficult to do after the house was assembled, so we recommend the doors be put in before the panels are attached. Again, we advise you to seek help from a local dealer, who specializes in these techniques.

Note: the parts of this house are numbered, to make it easier for you to work with them, and to know if anything is missing.

IF YOU HAVE A MISSING PART, LET US KNOW IMMEDIATELY, AND WE WILL FURNISH IT. IF YOU HAVE QUESTIONS ABOUT THE HOUSE, FEEL FREE TO WRITE OR CALL US AT 802-479-2217. OUR ADDRESS IS: REAL GOOD TOYS. BOX 706, MONTPELIER, VT. 05602.

We are proud of our reputation for being personally involved with every house we produce - for caring about our products, and our customers. We are proud, too, of the quality of our work. We guarantee your satisfaction with every part, or we will replace that part. If you think you have a defective part, send it to us with your name and address, and we will send you a replacement right away!! Oh, and by the way - we are always interested in seeing pictures of the houses that people create. If you feel like it, send one along!

HOW THE INSTRUCTIONS ARE LAID OUT:

There are two separate sections - written and illustrated. They should be read together. The illustrated section of the instructions is labelled with the Roman numeral and letter of the corresponding description in the written section. "I-B", for example, would be the "B" section of the group of written instructions under the "I" section. A cursory glance at the instructions will make this clear.

I. PREPARE FOR ASSEMBLY

A. Line up and identify parts, using parts list and drawings.

1. separate packs and panels
2. lay out in numerical order, so parts are accessible, and so you can tell if there are any parts missing. IF SO, CONTACT US AT ONCE. Don't forget to check the parts in the pre-packs.
3. Try to identify the inside and outside surfaces of the panels
4. Sand any of the openings (window, door, etc.) that you think need to be sanded. It saves time later.

B. Square off corners of openings (see diagram)

1. most of the openings have round corners, which need to be square for the pieces that go inside them to fit
2. They are squared off by simply cutting the corners out with a knife (kind of like whittling). A sharp pocket knife is a good tool here.
3. This is a fairly tedious job to do all at once, but easier to do now than a little at a time. Still, you can do this operation as you go, if you choose.
4. A tip: be sure to start the cut far enough back to insure a good, square cut.
5. A list of openings to square off: 14 regular windows, 4 gable windows, 1 dormer window (in pack #23), upper corners on door in panel 7, upper corner on door in panel #10, bottom corners on opening in panel #1, interior corners on floor panels, entryway stair sides (pack #22, and if you choose, the openings for the stairs
6. As you assemble, you will probably find that some of the openings need to be squared a little more - So always check before you put parts in the openings, and have the knife handy.

C. Identify the 4 main wall panels, and the 3 smaller wall panels (called "insets" on the parts list)

1. They are panels #1 through #7
2. Identify the inside and outside surfaces of the panels
3. To help you tell which side is which, we have numbered these panels on the bottom, inside edge.

D. Mark the location and position of each of the 3 floors on the inside of the wall panels

1. This is a preliminary step that will enable you to attach the floors in the right place with a minimum amount of work
2. You will need a yardstick or tape measure, and a pencil
3. With a pencil, make a mark on the panels IN 2 OR 3 PLACES at each of the following heights: 3 5/8", 4", 14", 14 3/8", 24 3/8", 24 1/2"
4. Connect the marks horizontally, using a straight edge
5. You now have six lines on each panel - 3 sets of lines 3/8" from each other. That 3/8" represents the position of a floor.
6. The lines do not have to be perfectly exact, but the closer they are to being accurate, the less margin for error there will be.

E. Pre-punch nail holes in the walls where the floors will be attached

1. This will help assure that when you nail the floors in, you will nail into the center of the plywood edge
2. You are going to nail a nail into the wall panels, from the

inside (centered between the 3/8"), all the way through so it emerges on the outside surface. Then you are going to remove the nail. Since nails sometimes bend when you pull them out, you may need to keep switching nails.

3. Nail as straight as possible, centering the nail between the lines that are 3/8" apart
4. When the hole is punched through the panel, with the nail still in it, turn the panel over and push down the splinters around the nail. This assure that there will be a visible hole from the outside surface when you remove the nail
5. Turn panel back over, remove the nail
6. Put three holes in each wide panel, one or two in the narrow panel

II. Attach parts to main wall panels before shell assembly

A. Attach side door and trim to panel 7

1. You need pack #16; 1 door knob, 2 small hinges, 8 nails from pack #14.
2. Lay panel #7 down, with outside surface up
3. Square off corners (or make sure the top of the door is square enough)
4. Run bead of glue on grooved side of door top and on its ends, then insert into the door opening as shown. Press up to get good bond.
5. Surface should be flush with the panel surface on both sides, door top perpendicular to door side edges
6. Insert door into opening, slide towards door top. Adjust door top to relative squareness with top edge of door
7. Run bead of glue on back of door top trim
8. Place door top trim as shown; straight edges at bottom are even with bottom edge of door top. Piece is centered over the door.
9. Run bead of glue on door sides, apply to panel as shown. Inside edge of doorsides is flush with the edge of the door opening. Top edge is up against the door top trim.
10. Exterior trim is now on. Remove door from opening, wait until glue sets, turn over panel.
11. Sand the door top surface smooth, so door top trim will sit flat
12. Run bead of glue on interior door top trim
13. Apply door top trim as shown, flush with door top edge, centered over the door opening
14. Apply door sides as shown, flush with the inside edge of the door opening
15. Allow trim to dry

B. Hang Side Door

1. You'll need a tack hammer, and, if you desire epoxy cement
2. Attach hinges (they are on the back of the door, which swings in)
 - a. Decide if you'd prefer to nail the hinges on, using the 3/8" nails we've provided, or epoxy them on. Either works fine. Hinges will be attached 1/2" from the top and bottom edges of the door as shown
 - b. Place hinge on door. Fold hinge over, so that the pin rests against the door. The hinge must be straight, or the door will not swing.
 - c. Glue or nail the hinge to the door
 - d. repeat with the other hinge
 - e. Turn the door over, attach the knob as shown; The knob is threaded and may be screwed in or tapped in with a hammer.

- f. Lay panel #7 face down
- g. Lay the door inside the door opening face down
- h. Line the hinges up on the right side trim, making sure that the door is straight in the opening and that there is a slight gap on the unhinged side so that the door will swing freely
- i. Make sure there's a gap at the base of the door as shown
- j. When you're satisfied with the positioning, nail or glue hinges in place.
- k. Test the door to make sure it's hung squarely. Readjust if necessary

C. Attach Bay Window Pieces to panel #1

- 1. You'll need pieces #8, #9, #32, and the two large hinges and 8 screws from pack #14
- 2. Lay panel #1 down, good side up
- 3. Attach bay window sides to panel #1
 - a. run bead of glue on edges of bay window sides (panel #8)
 - b. place on outside surface of panel #1, flush to the bottom edge of the panel, and flush to the inside edge of the opening
 - c. After it sets (when the glue is tacky), turn the panel over and nail through the panel, into the sides
- 4. Attach the bay window ceiling
 - a. locate ceiling (panel # 32)
 - b. run bead of glue on top of bay window walls, and the rear edge of the bay window ceiling
 - c. Place the bay window ceiling on top of the walls, flush with the walls' edges
 - d. Nail through ceiling, into walls

D. Attach Bay Window Front to Panel #1

- 1. Attach hinges to bay window front panel (panel #9)
 - a. Note top and bottom of panel (see diagram)
 - b. Decide on front, rear surfaces
 - c. Stand panel #9 on its side as shown
 - d. mark a pencil line on the edge of panel #9 (as shown) at 1" from the top, 1½" from the bottom
 - e. place hinge on edge at line, as shown. Make pencil mark in holes of hinge, so when you remove the hinge, there will be a mark where each of the screws will go.
 - f. Repeat with 2nd line, 2nd hinge as shown
 - g. Punch holes with nails at marks you made in hinge-holes, to start the hole into which you will screw to secure the hinges
 - h. Remove nails
 - i. Replace hinges, screw them onto the bay window front as shown

2. Attach the Front to Panel #1

- a. Lay panel #1 flat
- b. Lay bay front on it, as shown, with the left edge flush with the left bay window wall, up against the top edge of the bay window ceiling
- c. Hinges are hanging down over the left side
- d. With a pencil, trace the hinge-holes onto the left bay window side (as you did on the front panel)
- e. Remove the front
- f. Gently use nail to prepunch holes at traced holes
- g. Replace front panel
- h. Screw in hinges
- i. Stand panel #1 up straight. The bay window should swing freely. If not, make adjustments now.

III Pre-assembling the wall panels (easier with 2 people)

A. Before assembling the main house shell, 2 sets of wall panels must be pre-assembled

B. Attach Panel #6 and panel #5 together

- 1. Preset 2 nails in rear left surface of panel #6, 3/16" in from the edge as shown (Note: preset means to lay the panel down, and hammer the nail in place - but don't let it come all the way through the panel. This makes assembly easier, since you don't have to hold the nail)
- 2. Run bead of glue on one edge of panel #5 about 10" from the corner as shown
- 3. With one person holding panel #5 up (with glued side up), lay panel #6 on it as shown; hammer in the nails. Edge of panel #6 should be flush with surface of panel #5, top edge also flush with top edge of panel #5. Keep panels square to each other.

C. Attach Panel #6 to Panel #7

- 1. lay panel #6 down, preset nails (3) along right side as shown, 3/16" in from the right edge
- 2. Run bead of glue along front edge of panel #7. Note diagram to assure yourself that door is in correct position
- 3. With one person holding up panel #7 (glued edge in the air), lay panel #6 on it to form a corner. Bottom edges of the panels must be flush. Panel #6's right edge is flush with right surface of panel #7.
- 4. Hammer in nails. Keep panels square to each other

D. Attach panel #2 to Panel #1

- 1. Preset nails in panel #2 as shown, 3/16" in from the edge
- 2. Run bead of glue along right edge of panel #1
- 3. Lay panel #2 on it, bottom and side edges flush as shown
- 4. Hammer in nails. Note: for positioning reference, the angle on panel #2 continues the slope of the peak of panel #1

IV. Assemble the Main House Shell (a 2-person job!)

A. Attach base to rear foundation strip (panel F)

- 1. Run bead of glue along the foundation edge
- 2. Place base on foundation as shown, with rear and side edges flush
- 3. Nail through base, into foundation

B. Attach front foundation piece to base (panel #35)

- 1. Run bead of glue along foundation edge
- 2. Rest base on foundation as shown, with front edge flush, corner edge flush
- 3. Nail through base, into foundation

C. Attach #1 and #2 panels to the base and foundation

- 1. Before proceeding, make sure the bottom corners of the bay window are sufficiently squared off, as well as the rear inside corners of the base, as shown. This is important.
- 2. Run bead of glue along bottom edge of bay window opening in Panel #1
- 3. Put glue on the end of the foundation as shown
- 4. Insert the base into the bay window opening in panel #1. Make sure it's in all the way

5. Nail down through the base, into panel #1 (the bay window opening edge). To make nailing easy, hold a ruler (or straight edge) against the panel (#1) from the inside, and draw a pencil line across the opening of the bay window. Use this line as a reference. Nail 3/16" in from it.

6. Nail sideways through panel #1, into the foundation

7. Nail sideways, through panel #1, into the prepunched holes, into the base

D. Attach panels #6 and #7 to the base

1. Run bead of glue along base edge where panels 6 and 7 will go, and on the bottom edge of panel #5

2. Push the panels against the base tightly, giving special attention to the corner (make sure it's tight). One person should be on the inside to make sure that the base is approximately even with the lines you drew on the inside of the wall panels

3. Holding it tight, nail through the prepunched holes in the walls, into the base. Keep the nails as straight as possible

4. Panel 5 should be resting on the base panel when assembly is complete

5. Nail through panel #7, into the rear foundation strip

E. Attach panel #3 to the base

1. Run a bead of glue along the front left edge of the base panel, and along the front edge of panel #5

2. Preset 3 nails on right side of panel #3, in 3/16" from the edge, as shown

3. Hold panel 3 up in place, butting against panel 5 with its right edge flush with the right surface of panel 5. Left edge of panel 3 overlaps the base by 3/8".

4. Nail through prepunched holes into the base

5. Hammer in the preset nails into panel 5, keeping the edges flush and the bottom of panel 5 on the base

V. ATTACH THE SECOND AND THIRD FLOORS

A. Line up room dividers (panels # 13-17) against the walls as shown, to use them as spacers to hold up the 2nd floor while you nail it in

B. Lay the 2nd floor in place on the dividers to check the fit. When a good fit is ascertained, remove the floor

C. Run a bead of glue along the edge of the second floor, replace in position

D. Nail through the prepunched holes in the walls, into the second floor. One person should be spotting on the inside to make sure the second floor is approximately even with the lines drawn on the inside of the walls

E. Repeat this process with the third floor

F. Note: use damp cloth to wipe off excess, dripping glue

G. Attach Panel #4

1. Run bead of glue along both long edges of #4, and the exposed edges of the floors where #4 will go (front left corner)

2. Insert #4 into the slot between panels 2 & 3

3. Nail through prepunched holes of panel 4, into the floor panels

4. Nail through panels 2 & 3, into panel #4 as shown

VI. Attach the Rear Roof Strip (panel #18)

A. Mark Its Position

1. Determine the inside and outside

2. Lay it flat, with inside edge up

3. Measure in 1" from both ends

4. With pencil, draw a line a 1" where you've measured

B. Attach to roof

1. Run bead of glue 2 1/2" long, down from peak, on rear edge of peak as shown

2. Place rear strip on house as shown, lining up 1" lines with the edges of the house sides (panels 1 and 7)

3. If the 1" is not exact, then even the ends up so the overlap is equal

4. Bevelled edge must be as shown, with bevel continuing the front edge of the peak (roof line)

5. Nail in place

IF YOU'RE USING OUR FINISHING KIT, STOP HERE AND OPEN THE FINISHING KIT - TAKE OUT THE INSTRUCTIONS AND FOLLOW THEM

VII. Attach the Front Roof Panel (Panel #19)

A. Locate and position roof panel

1. Place roof panel in position on the house

2. With a pencil, mark the position of panels 1 and 7 on the back edge of the roof. Draw a line marking each side of the panels

3. Remove the roof panel

4. Lay it face down, so you are looking at the lines

5. Prepunch holes between the lines, centered and evenly spaced

6. Three holes for each side. Remove nails

B. Attach Roof

1. Run bead of glue along the front edge of the peak and along the top bevelled edge of the rear roof strip

2. Replace the roof in correct position, with ends even with rear.

3. Nail through the prepunched holes

4. Put four strips of masking tape across the top as shown. Pull tight to make a good, firm bond between the front and rear pieces

VIII. Attach rear roof vertical strips (panel #20)

A. Locate panels #d 20. Note bevelled edge-this will be at the rear, facing down as shown

B. Run Bead of glue along rear edge of peaks (panels 1 and 7)

C. Put strips in place, with their outside edge lined up with the outside edges of the rear roof strip, and the top edge pushed up against the back edge of the rear roof strip

D. Nail them in place

IX. Prepare Gable Roofs for Assembly

A. Put Gable Roofs in place, as shown (dry run)

1. Left panel overlaps right
2. Top edge of left panel is flush with the surface of the right panel
3. Back edges of both roofs are flush against the front roof panel (adjust until all of the above are true)
4. When in place, draw a line on the under side of the gable roof panels where they meet the front edge of panels 3 and 6 (as you did with the front roof panel, for prepunching holes)

B. Prepunch holes in roof panels

1. Remove panels, lay them with the line facing up
2. Prepunch holes as shown, 3/16" from the line (as you did with the front roof panel)

C. Do this with all four panels from the left and right gable roofs, then set them aside for awhile

X. Assemble the Dormer (packs #23 and #24)

A. Open the packages; from pack 23, take the front piece. Sand the opening, and square off the bottom corners of the window opening (if not already done). Identify the different pieces.

B. Run a bead of glue on the front edge of each of the dormer sides, and attach them to the dormer front

1. The outside edge of the sides will be flush with the edge of the dormer front
2. Important: the angle of the bevel on the top edge of the dormer side will match the angle of the dormer peak, and line up with it as shown
3. Allow to dry

C. Attach Dormer Roof

1. Lay dormer on its back, with the window opening facing you
2. Identify right and left roof panels, as shown
3. For dry run, test them in place (left overlaps right), and remove
4. Run glue on dormer peak, on the tops of the dormer sides,
5. Lay the right dormer roof panel in place. It rests on the bevel of the right side. Roof bevel lines up with the left side of the peak, forming a continuation of it. Press back, so the back edge of the roof is flat on the table (along with the back edge of the sides)
6. Run a bead of glue along the inside top edge of the right roof panel
7. Put the left roof panel in place. It is flat on the table, with the rest of the unit, and the top edge is flush with the surface of the right roof panel
8. Put pieces of masking tape across the roof panels (as you did with the main roof), pulling tight to keep the joint closed while the glue dries
9. Allow to dry

D. Apply Dormer window trim

1. Insert bottom window trim (from pack #24)
 - a. These are 2 1/8" X 1/8" strips that fit flush in the bottom of the window opening
 - b. each one fits flush to a wall surface (outside, inside)
 - c. there is a space between them that is for the window pane to sit in
 - d. before trying to insert them, make sure the bottom of the window is squared off enough
 - e. Insert as shown, putting a small bead of glue on the bottom edge of each piece
 - f. You may have to trim this piece with a knife to make it fit. Do this rather than forcing it, since the piece is very fragile
2. Strip paper off window pane (from pack #25 - this is the smallest of the windows in this pack - the others are gable windows)
3. Slip the side trim over the edge of the window pane, as shown
4. Insert bottom edge of window pane into space between bottom window trim pieces
5. Run small bead of glue on window sides, push window into opening as shown, with the sides fitting snugly in the opening. The front edges of the window sides must be flush with the front surface of the dormer
6. Insert the thin window arches into the window openings as shown, bending them slightly to fit into the opening. NOTE: This is a tricky move. The arches are fragile and can break easily. Do not force them. Run glue on the upper edge of the thin arches, bring them as close to the surface of the panel as possible (inside and outside surfaces)
7. Glue on the outside arch, leaving about 1/8" lip of the inside arch showing. The bottom edge of the outside arch is parallel to the bottom edge of the dormer front panel
8. Glue on the window verticals as shown, flush with the outside edge of the outside arch, parallel to the outside dormer walls
9. Glue the bottom trim molding on, butting up against the window verticals, parallel to the bottom of the dormer front
10. Glue the interior arch in place as shown, slightly overlapping the seam with the verticals

E. Attach Dormer to Left Gable Roof Panel (panel #21)

1. Make sure bottom corners on dormer opening on panel 21 are squared off
2. Lay panel 21 flat, with the outside surface up
3. Lay dormer on roof panel, over opening. Adjust til it's evenly placed over the opening, with its bottom edge flush with the bottom edge of the opening, sides flush with sides, etc.
4. With pencil, lightly trace around dormer front and walls, to note location
5. Remove dormer
6. Run bead of glue along rear edge of dormer - on roof, sides, bottom edge of dormer
7. Replace dormer in position - even it up, and make sure it's in position properly
8. When dry, turn the panel over and sand the edges of the dormer opening wher they meet
9. Glue the window sill from pack #24 to the edge of the gable opening as shown, butting up against the bottom trim

F. Attach dormer gable molding

1. Locate pack #18, remove the two smallest pieces from it. These are the dormer ledge molding pieces
2. Run a bead of glue on the front edge of the dormer roof
3. Put glue on the inside angle of the ledge molding, as shown.
4. Attach molding to the front edges of the dormer roof, flush to the top surface of the roof.

G. Attach Gable cross-pieces (from pack #24)

1. Glue horizontal cross-bar in, as shown
2. Allow to dry
3. Put dab of glue on top of vertical cross-bar, and in the center of the horizontal cross-bar
4. Glue in vertical by slipping it under the molding peak, and over the horizontal piece

XI. ATTACH GABLE ROOFS TO HOUSE (a two-person job)

A. Put roofs in position

1. You have already prepunched holes in both gable roofs (4 panels)
2. Attach roof for right gable first (no reason, but you have to start with one of them)
3. Run beads of glue along both sides of the peak on panel #6
4. Run bead of glue along the back edges of panels 24 & 25, and along the top edge of panel 25
5. Two people needed here: each person take one of the panels, hold them in position (rear edge against the front roof panel, left panel overlapping the right panel, making an even line)
6. Nail into the prepunched holes
7. To hold the joint at the top of the roof together, use masking tape pulled tight
8. Repeat the entire process with the left gable (panels # 21 and 22, on the peak of panel #3)

XII. ASSEMBLE THE INSIDE WINDOW TRIM

Before you get into this, we have a few notes for you to consider.

-The inside window trim is a frame that fits into the window opening, It is the first part of the window trim

-We are advised by our experts on dollhouse finishing that it is in your interest to apply the window trim after the house is assembled, and after it is wallpapered (wallpapering is easier after the house is together)

-This does, however, make the application of the window trim a little harder, so here are a few pointers to offset the extra work:

- It's easier to apply the trim with another person's help- one person on the inside of the house, the other on the outside. The reason for this: the inside trim needs to be flush with both the inside and outside surfaces of the walls. So while you're pushing from the outside, your friend can keep the trim from being pushed too far and frustrating you by constantly falling out

- Be sure to try each window without glue before actually gluing it. That way you'll be sure it fits

- Keep a knife handy while inserting the window trim. You may need to square a corner off more than you thought, and perhaps trim a piece to make it fit perfectly

OK. Now back to the instructions.

A. Open pack #5, separate the parts. Note the difference between the two 1/8" X 1/8" pieces. The shorter ones are the mullions.

B. Attach bottom trim

1. These are the 1/8" X 1/8" pieces that fit in the bottom edge of the window opening
2. You will insert 2 pieces in each window, each flush to a surface of the wall panel (inside or outside)
3. The space between them will be for the window pane to sit in
4. Make sure window corners are square before you try to insert the pieces
5. Run small bead of glue on the bottom edge of each of the pieces
6. Insert each piece into the window opening. Note: It's possible that you may have to trim the piece with a knife. Do this rather than forcing it, since the piece is very fragile
7. Allow bottom trim to dry in place before proceeding

C. Attach top section of trim

1. Strip paper off windows (these are pack #6)
2. Take the window sides, slip them over the window pane as shown
3. Slip the bottom edge of the window pane (still holding the window sides over it) into the space formed by the bottom window trim, slanting the window back
4. Put a dab of glue on the top of each window vertical
5. Slip the top trim over the top edge of the window pane, so it meets the window sides
6. Run a light bead of glue on top and along the sides
7. Push the whole unit forward, so it fits snugly into the window opening
8. All edges are flush with both inside and outside surfaces of the wall panels
9. Repeat process on all windows
10. Insert mullion between window vertical trim, putting a dab of glue on the sides or back if you desire

XIII. ATTACH THE EXTERIOR WINDOW TRIM

(There are four kinds of exterior window trim - 2 single windows, 2 kinds of double windows)

A. Arched single window trim

1. Open pack #8
2. Attach keystones to arches as shown
 - a. put dab of glue on back of keystones
 - b. apply keystones to arches in center, with bottom edges of each flush
 - c. Allow to dry
3. Attach arch to window
 - a. Put glue on arch back
 - b. apply arch to panel
 - c. The flat bottom edges of the arch are even with bottom edge of inside window trim top
 - d. Important: inside top edge of arch covers the joint where inside trim meets the window opening
4. Attach shutters (pack 10)
 - a. apply glue to backs of shutters
 - b. attach shutters as shown, parallel to the inside window trim side

5. Attach bottom trim
 - a. there are 2 different bottom pieces: a thin 1/8" X 1/8" piece, and a wider 1/4" piece
 - b. Put glue on one edge of the 1/8" X 1/8" piece, place it between the shutters, just below the inside trim. Bottom edge is even with bottom edge of shutters
 - c. Glue 1/4" piece below thin piece, up against bottom edges of shutters, spaced evenly between them as shown

B. Arched Double Window trim

1. Open pack #9. These will be the lower windows on panel #3, and the windows on the bay window
2. For panel 3, tilt the house back so you can lay out the parts without having to glue them first. For the bay window, tilt the house sideways. Placement of these pieces is important.
3. Glue keystones to arches as shown
4. Place arches, with center triangle, in place as shown.
 - a. Outside bottom edges of arches are approximately even with bottom edge of inside window trim top
 - b. arches cover joint between inside trim piece and window opening
 - c. arches meet center triangle, but do not necessarily butt up against it
 - d. adjust until even - do not glue until the entire window trim (including shutters) is laid out
5. Place shutters in position. Center shutter is set evenly between windows, outside shutters are parallel to vertical inside trim
6. Place thin bottom trim pieces between shutters as shown
7. Place 5 1/2" long bottom trim piece as shown
8. When whole trim assembly is laid out, remove piece by piece and glue.

C. Double window trim with awning

1. Open pack #11. These will be the upper windows on panels #3 & 1
2. Apply upper horizontal trim piece as shown.
Glue so bottom edge is flush with bottom edge of inside window trim, evenly spaced on the sides
3. Glue shutters in place, outside shutters parallel to inside trim. Inside shutter is spaced evenly between the windows
4. Glue thin trim between the shutters, bottom horizontal trim below the shutters as shown.
5. Sand the 2 decorative triangles
6. Glue them on each of the long awnings as shown
7. Glue roofs in place, about 1/4" above the assembled window trim unit as shown

D. Single window with small awning

1. From pack #11. This is the upper right window on panel #6
2. Follow same steps as C (double window with awning) There is no center triangle.

XIV. ATTACH INTERIOR WINDOW TRIM

- A. Open pack #4, separate horizontals from verticals. Sand them where desired (round off edges, take fuzz off ends)
- B. Attach trim
 1. Run bead of glue along backs of 2 horizontals, 2 verticals
 2. allow to get a little tacky (sticky)
 3. Apply bottom horizontal, centering it so each end sticks out an equal amount, with about 1/32" of the inside frame showing
 4. apply 2 vertical trim pieces, butting them against the bottom horizontal, flush with its outside edges. About 1/8" of the vertical inside molding should be showing
 5. Apply top horizontal trim. It rests on the top ends of the verticals, with approx. 1/32" (equal to the bottom horizontal) of the inside trim showing
 6. These should be even and square. As you apply them, compare them to each other to maintain uniformity. Also, step back from each one to check it out and see that it's square.

XV. Attach Gable Window Trim

- A. Open pack #15. Use the four larger windows from pack #25. Check the bottom corners of the window openings to see that they are square enough.
- B. Insert bottom trim pieces, flush with the front and back surfaces of the panels, as you did with the standard windows
- C. Attach Window Pane
 1. Strip paper off windows
 2. slip window sides over the edges of the window panes, as you did with the standard windows
 3. Slip bottom edge of the window pane (still holding the window sides over it) into the space formed by the bottom window trim, slanting the window back
 4. Put glue on the outside edges of the window sides, then push forward in to the opening until the sides are flush with the surfaces of the panels (inside and out)
- D. Insert the Inside Window Arch
 1. This is a tricky maneuver. To get the arch to fit, you have to flex it (bend it) a bit. All you need to do is get it in, and up as far as it seems natural to go. Don't force it.
 2. Hold one side of the inside window arch against the inside edge of the window opening
 3. Gently bend the trim piece until it fits into the opening
 4. Rotate the trim piece until it's even
 5. It should be flush with the surface of the panel (both)

E. Attach outside arch trim pieces

1. Put glue on the back of the arch
2. Place it over the inside window arch, so about 1/8" of the inside arch is showing.
3. Bottom edges should be parallel to the bottom edge of the window opening, and even with the bottom edges of the inside window trim.
4. Repeat on the reverse side

F. Attach arch vertical trim

1. Glue verticals as shown, covering the seam between the window opening and the inside window vertical trim
2. Repeat on other side
3. Trim is butted up against outside arch trim

G. Glue bottom trim in place, butting up against vertical trim as shown. Glue on both inside and outside surfaces.

XVI. ASSEMBLE ENTRYWAY STEPS

A. Open pack #22. take out sides (with step cutouts), square off the inside corners of the pieces

1. lay notched pieces face down (these are the risers)
2. put dab of glue in the notches of the smallest riser
3. put glue on the ends of the large rectangular piece
4. stand up one of the sides, attach rectangular piece as shown, back edge flush with back edge of sides
5. stand up smallest notched piece, attach as shown
6. Try to make sure unit is square
7. Let unit stand for a few minutes, until glue is tacky

B. Put glue in the notches of the rest of the risers, and apply to stair unit as shown (be gentle, as unit may tend to shift out of square, and then it will fall apart - you'll have to start over again !)

C. Glue treads on as shown

D. This unit goes in the front of the house, up against the front foundation piece, and in front of the entry way. If you choose, you can glue it to the house.

XVII. ATTACH BAY WINDOW ROOF

A. Open pack #26

B. glue longer triangles to bay window ceiling, as shown, using outside edges of the windows as positioning guide. Glue shorter triangles as shown, starting at the corner edges

C. Glue on roof panels

1. note bevel on back of large roof panel, in joint where small panels connect to large one. Dry run: place panels in position, making sure bevels are as shown. Panels rest on triangles.
2. When you're sure of how they go, remove the panels
3. Run bead of glue on the top edges of the triangles, the back edge of the long roof panel, the edges of the small roof panels that connect to the large one, and the back edges of the small roof panels.
4. Replace pieces in position
5. To secure the joint between the large and small roof panels, use masking tape, pulled tight across the joint until the glue is dry
6. Note: roof is flush against house

XVIII. CHIMNEYS

A. There are two different chimneys - the peak chimney, on the left, and the sloped chimney, on the right. They are in packs #20 and #21, respectively

B. Assemble Peak chimney

1. Open pack #20, sand panels
2. Lay one side (a piece with the notch in it) flat
3. Help! I'm trapped in a dollhouse factory! (Just kidding, folks)
4. Run bead of glue on side of each end piece, attach as shown. Top and outside edges are flush
5. Lay opposite side (notched piece) on the unit, keeping top and sides flush, and keeping unit square
6. Let dry. Sand corners smooth
7. Apply top trim
 - a. Glue wide trim around top as shown, even with the top edge. Short trim is applied first, even with the edges of the chimney. Longer trim overlaps on the end.
 - b. Let dry, then sand smooth
 - c. Glue narrow trim over wide trim as shown, centered on the wide trim
8. Chimney sits on peak at left

C. Assemble sloped chimney

1. Open pack #21, sand panels
2. Repeat assembly procedures, following diagrams
3. Chimney sits on rear roof strip, on right, as shown

XIX. SET UP THE DIVIDERS

A. There are 4 dividers with doors cut in them, panels # 16 (1st floor divider, slightly longer) and #17 (3 of them - one for 1st floor, 2 for 2nd)

B. There are 3 dividers with arches cut in them: #13, which is attached to panel #34 to form a corner that fits in front of the bay window #14, which goes in the first floor, and #15, which goes in the 2nd floor.

C. Attach panel #13 to panel #34 - run bead of glue along edge of #34, join the 2 panels as shown. Nail if you like. top and corner edges are flush:

D. Put dividers in place, as shown. If you think of an arrangement you like better, however, go right ahead! When you decide where you want them, run a bead of glue on the tops and bottoms, and slide them into place

XX. ASSEMBLE THE STAIRS

A. Open Pack #1.

- B. Lay out stair assembly
1. Lay plywood stair back with bevel face down on a table
 2. Lay out 13 stair treads on each stair back
 3. Note slight space between stair treads necessary to make it come out to the end on both ends.

C. Assemble Stairs

1. Remove treads from stair backs
2. Apply glue to entire surface of stair backs
3. One by one, starting at the top, put treads back in place.

Complete this step before glue is dry. Remember: steps are about 1/32" apart

4. When dry, rub the stair edge on sandpaper to flatten the sides.

XXI. ASSEMBLE THE BANNISTER

A. There are 2 sizes of bannisters - the first floor has a larger bannister, as shown

B. Attach staircase side

1. Run bead of glue along edge of staircase, as shown
2. Glue side to staircase. Bottom of side is flush with surface of stair back. Grooved side is up.
3. Important: bevels of side should line up with bevels of stair back
4. If necessary, nail to staircase

C. Assemble bannister

1. Run bead of glue in groove of staircase side
2. With assembly flat (as shown), insert dowels in groove, making sure they are perpendicular to the side piece. Dowels may be spaced regularly by using the stair treads as reference points
3. Put a dab of glue on the top end of each dowel
4. Take top rail and place grooved side down on the dowels. Dowels will fit in the groove
5. Make sure all dowels are straight and set in the groove
6. Before the glue is completely dry, shift the upper rail so that the dowels are perpendicular to the stair treads, as shown

D. Attaching Stairway and bannister to the unit

1. Square off stair openings
2. Fit stair way into opening, with top step even with floor surface. Glue in place if you desire.

XXII. ASSEMBLE THE STAIR BALCONIES

A. Open pack #2, separate railings according to size - match them up in pairs.

B. Assemble railings

1. With pencil, mark a railing piece on its grooved side at 7/8" intervals
2. Run a bead of glue in the railing groove
3. Stand the railing dowels in the groove at the pencil marks. Keep the dowels as straight as possible
4. Run a bead of glue in a matching railing
5. Put the top railing on the railing assembly. Be particularly careful, as dowels may tend to fall. If they do, still concentrate on fitting the top rail over the remaining standing dowels. When this is complete, then gently straighten the fallen dowels.
6. Lay the assembly on its side
 - a. Push one end of the assembly against a straight edge. Ends should now be even. This is important

b. If necessary, straighten dowels. Gently push top ends upright until all dowels are parallel.

7. Set railing assembly aside to dry
8. Repeat with all railing pairs

C. Glue caps to columns, as shown

D. Glue columns to rails as shown. For the second floor, there is only one railing with two columns. For the third floor, there is a corner balcony.

E. After stairs are in place, glue balconies in place.

XXIII. ASSEMBLE THE FRONT DOORS

A. Open pack #13, lay the pieces out as left and right doors, as shown. Remove 2 door knobs, 4 small hinges, 16 3/8"-nails from pack #14

B. Glue the door together

1. Mark a pencil line 5 1/4" from the bottom of each door side (pieces A & B, as shown)
2. Work with one door at a time
3. Run a bead of glue in the grooves of pieces A (from the 5 1/4" line to the bottom) and C
4. Put a dab of glue on one end of piece C, attach to piece A as shown, forming a right angle. Bottom edges are flush
5. Slide short panel D into the grooves of side A and bottom piece C, keeping the good face of the panel toward the outside. Keep the bottom edges flush
6. Run a bead of glue in both grooves and on one end of the middle piece E, and put it in place as shown. Take care to keep the whole unit square, and the bottom edge flush
7. Slide long panel F into the grooves of side A and middle piece E as shown
8. Run glue in one groove and on one end of middle piece G. Put in place with the glued groove over the edge of the long panel F, glued end against side A
9. Run bead of glue along the uncovered edge (the edge on which the side has not been attached) of the door, as shown. Run bead of glue in door side B groove.
10. Attach side B to assembled unit as shown
11. Making sure surface is as flat as possible, and that the bottom piece C is flush with the bottom edges of sides A and B, wrap a rubber band around the bottom section as shown
12. Peel the paper off the window piece, and slide it between the grooves of sides A and B, resting in groove of middle piece G
13. Put glue on the ends of arched piece H
14. Slide its groove over the window, with glued edges between sides A and B. The top should be flush
15. Check out the picture of what the finished doors should look like
16. Set it aside to dry
17. Repeat process with the other door

C. When the doors are dry, sand them flat (and sand off any excess glue)

XXIV. ATTACH FRONT DOOR TRIM

A. Open pack #12, lay out and identify the parts. You also need the doors, and panel #10 (the entryway front). Make sure the corners are adequately cut out of the door top. The door trim won't fit otherwise. It's better on these corners to over-cut than under-cut.

B. Place the inside-edge trim on the door opening

1. Put top trim in
 - a. This is very fragile. You are going to bend the smaller pine strip to fit into the arch of the front panel as shown
 - b. Put one end in one top corner of the door dutout
 - c. Bend gently, moving the other end up toward the other corner. **DO NOT FORCE IT!**
 - d. When in place, it should rest against the top arch edge with both corners tight & flush to the front surface of the panel
 - e. Remove it, run a bead of glue along one surface, and replace it in position

NOTE: AN EXTRA PIECE IS PROVIDED IN CASE YOU BREAK THE FIRST ONE

2. Glue the inside vertical trim in place as shown, flush with the front surface of the panel. The bottom should be flush with the bottom of the panel (trim it if it's not flush)

C. Attach exterior door trim

1. Lay the front trim on the front panel as shown
2. Bottom edge of arch overhangs the top of the door
3. The vertical trim is flush with the side and bottom edges of the door opening
4. Note on diagram: the position of the slant on the vertical trim
5. Remove the trim, apply glue to the back edges of the pieces, and replace in position
6. Glue the keystone in the center of the arch, as shown
7. If the top arch warps, and doesn't want to stay in place, put some weight on it

D. Attach Interior Molding

1. Turn panel over (face down)
2. Lay trim on it, as shown
 - a. Sides are flush to the bottom edge and to the inside edge of the door opening
 - b. The top arch is centered over the door opening, flush against the tops of the side trim
3. Remove the trim, apply glue to the backs of the pieces, and replace in position, attaching the vertical pieces first

E. Attach Hinges to the doors as shown, following the directions for putting hinges on the side door.

F. Attach knobs as shown, following directions of side door

G. Hang Front Doors

1. Lay front panel (#10) face down
2. Fit the doors in the opening, with the tops hitting the inside-edge trim. Make sure there's a little clearance on the bottom between the bottom of the doors and the side trim.
3. Gauge a practical distance to space the doors from the sides, so hinges will be effective, doors will swing. Do the same on top. doors do not have to be flush up against the top arch.

4. There will be a space between the doors at the center. Don't pay too much attention to it now, except to make sure that it's big enough to allow the doors to swing. It will be covered later
5. When you have the doors set in the space properly, nail in the hinges, as you did with the side door
6. Remember: the doors open in

H. Turn the front panel over, so it's face up

1. Close the doors
2. Glue the last piece, which covers the space between the doors, onto one of the doors as shown, so it's exactly in the middle of the door opening. Make sure it doesn't impair the door's ability to open and close.
3. Let dry.

XXV. ASSEMBLE AND ATTACH ENTRYWAY

A. You'll need: panels # 10 (front), #11(ceiling), and #12 (side)

B. Assemble entryway

1. Run a bead of glue along a short edge of panel #12
2. Lay panel #11 on it, forming a corner as shown. Edge is flush with surface of panel #12. Nail in place
3. Lay assembled unit on its back
4. Run a bead of glue along the top edges (around the corner)
5. Lay the front panel (#10) on the glued edges (make sure it's right side up !!), nail it to the unit. Edges are flush

C. Attach entryway

1. Run a bead of glue along the bottom front edge, the left side edge, the back and top edges of the entryway
2. Put it in place as shown, snugly in its corner.
3. You can nail it from inside panel #6 and #3, but it is not necessary; If it needs some help keeping it in place while the glue dries, use masking tape or prop something up against it.
4. Note: right bottom edge of the entryway hangs down, unsupported. This will rest on the porch floor later.

XXVI. ASSEMBLE PORCH

A. Assemble Lattice Work

1. Open Pack C. Separate parts according to size (refer to parts list)
2. On a flat surface, lay out the lattice frames. There are two 3 5/8" X 8 1/2" frames, and three 3 5/8" X 6 3/8" frames
3. Make the frames one at a time
 - a. Put glue on the ends of the longer frame pieces
 - b. Attach the end pieces to the longer frame pieces; squeeze them together, making the glue ooze out a bit at the joint.
 - c. Make sure the frames stay square, and don't stick to table
 - d. Let all 5 frames dry
4. When frames are dry, sand one surface smooth and flat. This will be the outside.
5. Open pack D. Sort out the parts according to size (refer to parts list)
6. Take a larger frame, attach two of the pine supports to it, as shown
 - a. run a bead of glue in the grooves of the pine support as indicated
 - b. Line up the top and bottom edges - make sure they're flush
 - c. Stand up the frame assembly, as shown, to make sure the bottom is even
 - d. Remember: outside edge of the pine supports is the narrow side
7. Open pack C. Separate the parts according to size
8. Lay them on the frame, as shown in diagram, approximately using the width of one of the sticks as a spacer
 - a. begin with 2 sticks, each with an end in a corner, as shown
 - b. lay out the rest of the sticks without gluing, to get a clear idea of how they go
 - c. Next: remove the sticks one at a time, putting a dab of glue on the back of each end, and replacing it as you go.
 - d. Continue until all the sticks are in place, glued to the frame.
9. When the first long frame is set, take the other long frame, run a bead of glue in the groove of the pine support already attached to the first long frame, and insert the 2nd long frame into it as shown
10. Find corner support (with corner grooves in it). Insert other end of second long frame into corner groove. DO NOT GLUE IT ON!
11. Glue lattice sticks onto frame, following same instructions as the first frame. Leave to dry
12. Repeat entire process on small lattice frames, following diagrams. When you get to the last one (the one with the corner support), remove the corner support from the long frame unit (remember, you didn't glue it on) and use it with the small frames. This time you can glue it.

B. Assemble the lattice cross-pieces

1. Lay the first 2 cross-pieces down in the corners, as in step 8a, above (as shown)
2. With a pencil, draw a line along one edge of each cross-piece
3. Remove the pieces one at a time, and put a dot of glue on each of the lattice pieces along the pencil line (as shown)
4. Replace each cross-piece. You now have 2 pieces glued in place. You will use them as a reference to assemble the others
5. Repeat the operation with all the other cross-pieces
 - a. lay them out without gluing, using the approximate width of one cross-piece as a spacer between the pieces that will be glued.

- b. draw a pencil line along one edge of each cross-piece
 - c. Remove the pieces one by one, applying glue along the pencil line and replacing the pieces
6. Do this with both long frames, and then set the entire unit aside to dry. To do this with the long frames, you must remove the corner support from the small frame and put it on the large frame again. When the unit is dry, you will move it back to the small frame and this time, glue it
 7. Repeat the entire process with the small frame unit, as shown. Let dry.

NOTE: WHEN ASSEMBLING THE LATTICE PIECES TO THE FRAMES, IT'S A GOOD IDEA TO HAVE A STRAIGHT EDGE ON BOTH SIDES OF THE FRAMES SO THE PIECES DON'T STICK OUT PAST THE EDGES (IF THEY DO, YOU'LL HAVE TO SAND THEM)

C. Attach lattice work to porch base

1. Lay porch base with bottom up as shown
2. Dry run: put lattice work on porch base as shown, with front edge of the pine supports flush with the edge of the porch base. Slide the long frame into the groove of the corner support (so the entire lattice work is connected as a right angle)
3. Remove and run bead of glue along top edge of lattice work. Replace in position as shown
4. Even up outside edge of supports with edge of porch base - for reference: corner support is flush with porch base corner
5. Open pack E (foundation blocks)
6. Run bead of glue along the end and edge of the foundation blocks.
7. Place against pine support as shown. Note: these support the porch base and are used to square off the lattice work (to keep it from tilting in) Foundation blocks are flat on the porch base.
8. Attach panel #30, the rear porch foundation, as shown
9. Set aside to dry

D. Assemble railings

1. Before building the railings, use one to mark a "line" on each column side that has a groove on top. Pencil line is 1/4" from the bottom, as shown. It marks the position of the railings.
2. Find appropriate matching railings in pack #G (each one should have a mate)
3. With pencil, mark one of the railings on the grooved side at 7/8" intervals
4. Run a bead of glue in the railing groove
5. Stand railing dowels (also from pack G) in the groove at the pencil marks. Keep the dowels as straight as possible
6. Run a bead of glue in the matching railing
7. Put the top railing on the railing assembly. Be particularly careful, as dowels tend to fall. If they do, still concentrate on fitting the top railing over the remaining standing dowels. When this is complete, then gently straighten the fallen dowels
8. Lay assembly on its side. Push one end of the railing assembly against a straight edge. The ends should be even. THIS IS IMPORTANT. If necessary, straighten dowels. Gently push the top ends upright until all dowels are parallel.
9. Set railing assembly aside to dry

E. Put together column-railing subassembly

1. Check out how porch columns will go - see diagram to understand how they line up
2. Each side with a groove on it is marked at 1/4"

3. Put glue in grooves of columns 1 and 2 (according to diagram)
4. Line them up on straight edge (a panel will do)
5. Place large piece of gingerbread from pack H between the columns, slide it into the grooves
6. Put glue on ends of one of the longer porch railings, place between the columns as shown; to keep the rails at the same exact height, you might want to use a $\frac{1}{4}$ " piece of wood to space the rail from the straight edge. Otherwise, use the lines you drew at $\frac{1}{4}$ " from the bottom. This would be bottom edge of the railing when it's in place.
7. Squeeze the columns together, with railings flush to the spacer (or pencil line)
8. Check to make sure the top edge of the porch gingerbread is even on top, and still in the grooves
9. Wait until unit dries - make sure it's square and even
10. Next step: similar to the step using the corner porch support - you will attach one end of a railing to a column permanently, and leave the other loose. You will attach one end of the gingerbread permanently, and one end of it in the groove of a column UNGLUED.
 - a. Put glue in the other groove of column 2
 - b. Find corner porch column (column 3)
 - c. Slide a piece of long porch gingerbread between the columns as shown (column 2 and 3). The left side will be glued, but the right side is only there for support
 - d. put glue on one side of the other large railing, and insert it between column 2 and 3 as shown. Make sure it's even with the pencil line, or that you're using the $\frac{1}{4}$ " spacer
 - e. Squeeze the columns together so there's pressure on the railing that's glued
 - f. Leave the unit to dry.
11. Repeat the steps E1 through E9 with the smaller railings and porch gingerbread, lining up the columns as shown in the diagram.
 - a. When you get to the last column (you're working with the small gingerbread and railings), that is column #3, the corner column.
 - b. Remove the corner column from previous assembly (remember, you didn't glue it), and use it as shown (it's important that the grooves go exactly the right way). You may glue it to the small railing assembly
 - c. Be careful when you remove the corner column from the long railing assembly, as that assembly is a little fragile

F. Glue on porch edge trim, pack L, as shown

G. Glue porch floor to house

1. Run bead of glue on inside edges of porch floor, and on left edge AND on bottom edge of entryway side
2. Butt left edge against entryway floor, under entryway side (but touching it). Inside edges are flush against the walls
3. Rear porch foundation is also glued to rear of house
4. Allow to dry.

H. Glue rear porch supports in place

1. run bead of glue along one side, one end of supports
2. glue in place, as shown, against the house but resting on the porch floor. Note: when you glue these onto the house, it may make finishing the outside more difficult. Consequently, you may want to trace around the porch supports, do your exterior finishing and then come back to this step. It's up to you.
3. Allow to dry

I. Attach columns to porch floor

1. Stand up the two railing-column assemblies, and attach them at the corner the way you did with the lattice-work. Glue the long rail and gingerbread that is unattached to the corner porch column as shown. Use masking tape to secure it until dry.
2. Keep the whole assembly unit square and vertical
3. Position the columns on the porch floor.
4. Remove them, put glue on each of the bottoms (or each of the railings too, if that's what you've chosen), and replace in position

J. Attach Porch ceiling

1. When columns are tacky, but NOT DRY on the bottom, place porch ceiling on the unit. The reason you do not want to wait until the columns are dry is that they will probably need to be adjusted.
 - a. Put glue on top of each column, and on the porch support columns
 - b. Run bead of glue on inside edges, left side of porch ceiling
 - c. Butt ceiling against entryway, inside edges against house, rear end resting on the porch support columns
2. Adjust columns by pulling them out flush to the front edge of the porch ceiling, keeping them vertical and in position
3. Allow to dry

K. Attach Porch roof

1. Open pack J
 - a. run bead of glue on bottom side of triangles
 - b. put in place as shown. The only tricky one is the corner triangle, which is the largest, and has two bevels. This can be lined up easily by sighting down the line from the corner of the house to the corner of the porch. The line between the bevels on the corner triangle should correspond with the house-to-porch line.
 - c. Make sure the triangles are set so their backs are flush to the wall of the house. If they're upside down, the triangles will angle away from the wall
2. Lay roof panels on the triangles before they're dry. If the fit is good, remove the panels and put glue on the top surface of the triangles, then replace the panels, butting on the left against panel #5
3. Sand the joint between roof panels when dry.

L. Attach Porch Molding

1. Pieces A and B are the porch molding
2. Run bead of glue on the back of each & on the top edge, & corner
3. Put in place, as shown. Molding meets at mitered corner
4. Either use small nails, or masking tape to keep pieces in

place while they dry

XXVII. Attach Gable Gingerbread

A. Assemble gable gingerbread triangle

1. Open pack #19, sort out parts
 - a. 2 larger triangles, larger "arrow", longer trim pieces
 - b. smallest triangle goes with smallest parts, medium-sized triangle goes with medium-sized parts
 - c. circles don't need to be sorted yet
2. Procedure for gluing trim is the same for all four triangles
 - a. lay out trim as shown. Do not glue, but fit the pieces together to see how they go
 - b. Again without gluing, lay appropriate triangle on the trim, with bottom lip of trim sticking out past triangle 1/8"
 - c. See how it goes? (check the diagram)
 - d. Now remove the triangle & glue the three outside pieces to the "arrow" at the joints. IMPORTANT: the only joint the you've got "slop" on is the top angle, because you don't see that one once the triangle is glued over the trim. So leave that with a gap, if necessary, but make sure that the other joints are tight.
 - e. Run bead of glue on the back of the appropriate triangle, and put it in place. Remember: 1/8" lip on the bottom
 - f. Glue all the triangles and trim, doing a dry run first to make sure you've got the right pairs
 - g. let dry.
3. Glue on circles as shown. Dry run will allow you to match up the right circle with the right triangle before gluing
4. Open pack #18, sort the 4 pairs of ledge molding (there's a left and right piece of each)
 - a. the longest (2 pair) go on the end gables (panels 1 and 7)
 - b. the middle size goes on the left front gable (panel 3)
 - c. the shortest goes on the right front gable
5. Glue the molding on the gable roofs
 - a. run bead of glue on the back edge of the left and right pieces of one of the molding pairs - wait a minute, we forgot to tell you to hold the molding up to the gable roof first, so you see how it goes. OK, now do the glue. Put dab of glue on the edge of each piece of molding at the top where they meet
 - b. Put a piece of masking tape in each spot shown in the diagram, leaving the end wrapped over the top of the molding, but loose
 - c. Put moldings in place as shown, pulling the end of the tape tight to hold the molding flush against the roof edge while it dries. At the peak, the molding should meet snugly as shown
 - d. Glue all four sets of ledge molding in place, let dry
6. Glue horizontal "holy" gingerbread onto triangles
 - a. Once again, line up the appropriate piece with the appropriate triangle, in order of size
 - b. Run bead of glue on the overhanging lip on triangle trim
 - c. Put gingerbread in place as shown. Center it on the triangle - equal amount of lip showing on right and left

7. Glue on vertical trim piece
 - a. locate trim pieces (all the same size)
 - b. put dot of glue on end of piece, put on triangle back as shown, hanging down from the assembled triangle (with "holy" gingerbread)
 - c. Glue diamond on tip of vertical piece
3. Attach triangle to gable
 - a. match appropriate triangles to appropriate gables
 - b. run bead of glue along outside edges, top edges of triangles
 - c. put triangle up under the edge of the ledge moldings, as shown; you will have to remove the tape from the ledge molding first. Push the triangle firmly up into the peak of the gable, until the glue begins to ooze out (don't forget - you have to wipe this off before it dries)
 - d. Put masking tape on triangle, as shown, beginning underneath and behind the triangle, and coming up 2" onto the roof. This will hold the triangle in place as it dries. Pull tight.
 - e. Let dry. But make sure the triangle is in proper position, and check it a few times to make sure it hasn't slipped or that the masking tape hasn't come off. And again, wipe off the excess glue before it hardens.
9. Attach long "holy" gingerbread pieces. Sort out by size. The longer pieces may vary a little, but it's almost imperceptible, and doesn't matter. The shortest set is very noticeable.
 - a. Match appropriate long "holy" gingerbread to appropriate gables. To do this, remove the tape holding the triangles up (after the triangles are dry, of course), and hold the gingerbread up to the triangle AS SHOWN. It's important that the correct end be held up. Match the correct angle. If the angle's right, the piece is right.
 - b. Run bead of glue on the outside edge and top edge of each piece, as shown. Put a dot of glue at the point at which the long gingerbread meets the horizontal gingerbread
 - c. Put long "holy" gingerbread in place, up against underside of the gable roof panel, butting up against horizontal gingerbread
 - d. Put masking tape as shown, attaching from the back of the gingerbread, but not pulling tightly. You have to be careful to hold the gingerbread in place without slanting it forward, or moving it away from the joint with the horizontal.
 - e. do all the gables, then let dry.
 - f. remove tape. Voila! Your house is done!

SECTION I

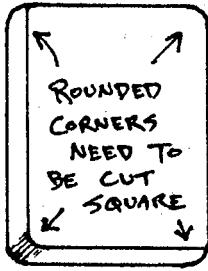

B-1

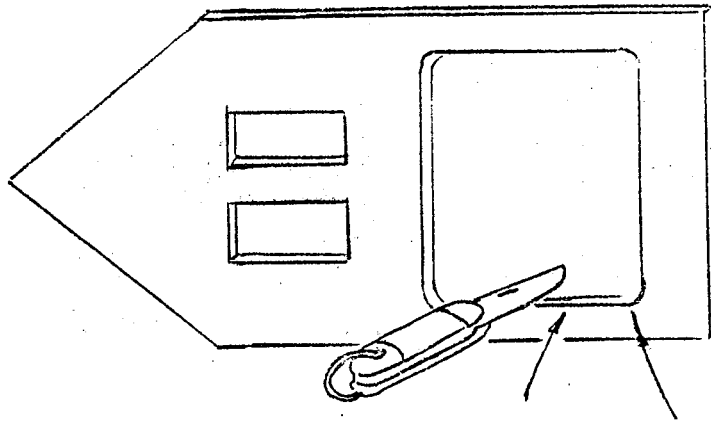

START CUT HERE... NOT HERE

B-4

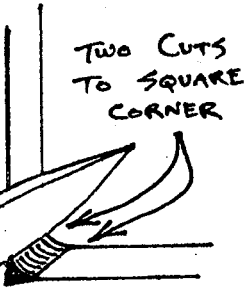

B-2

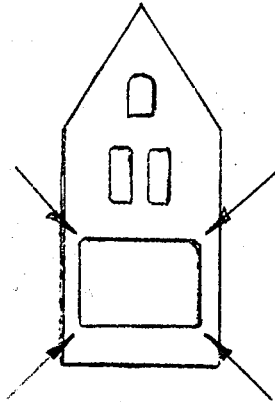

B-5

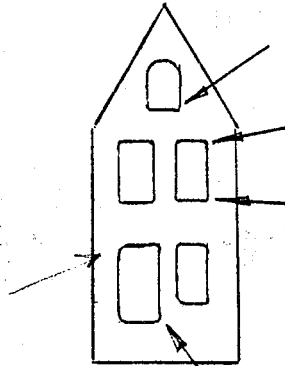

B-5

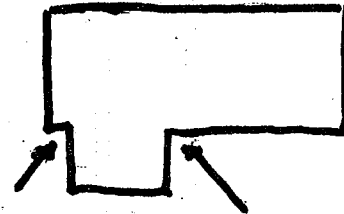

B-5

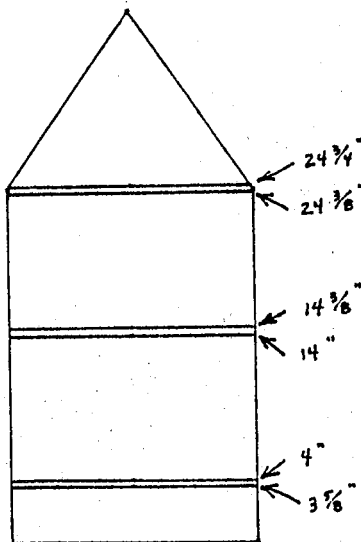

D3-5

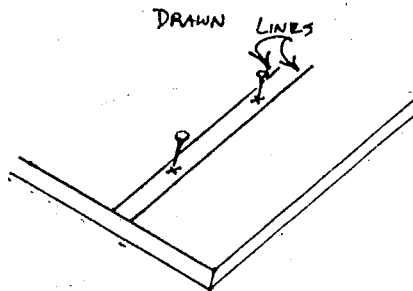

E-3

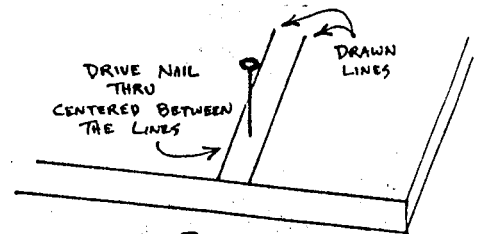

E-3

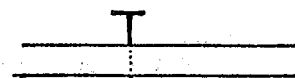

E-2

SECTION II

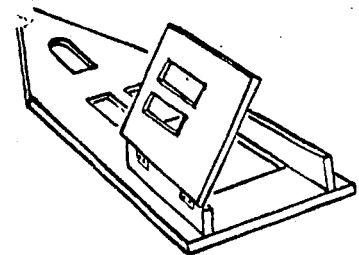
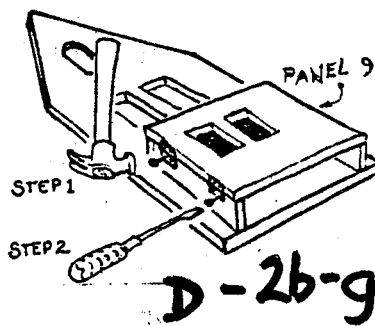
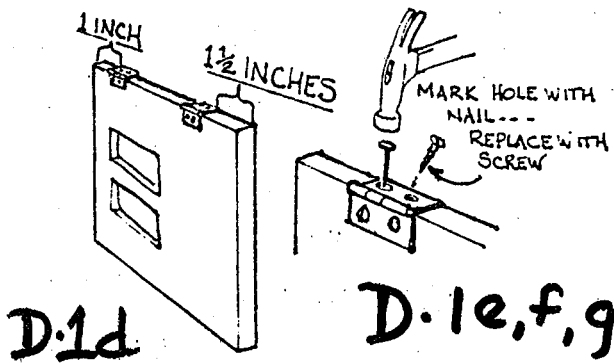
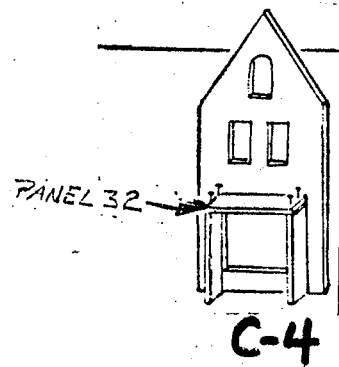
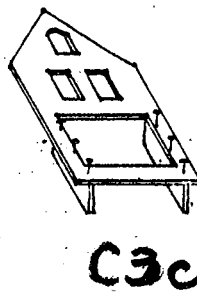
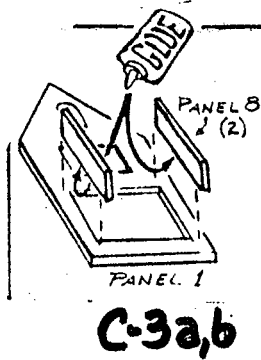
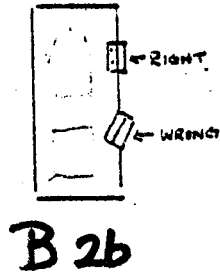
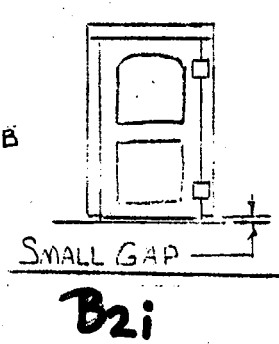
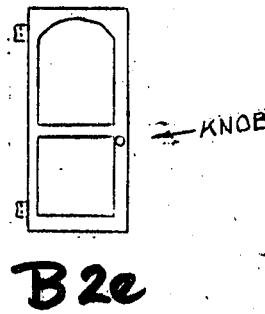
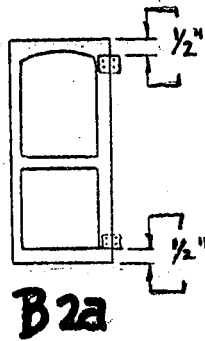
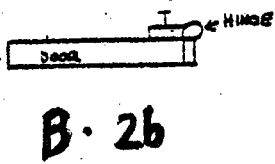
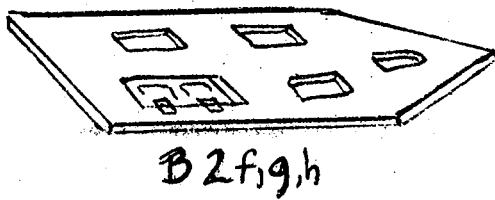
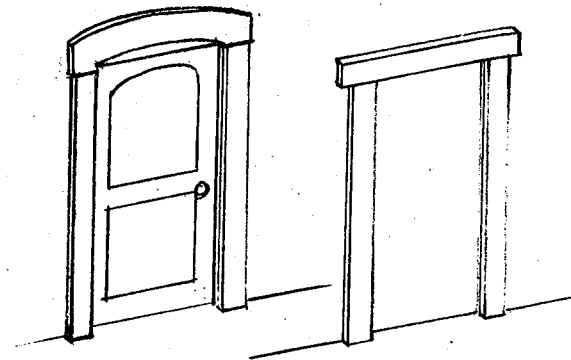
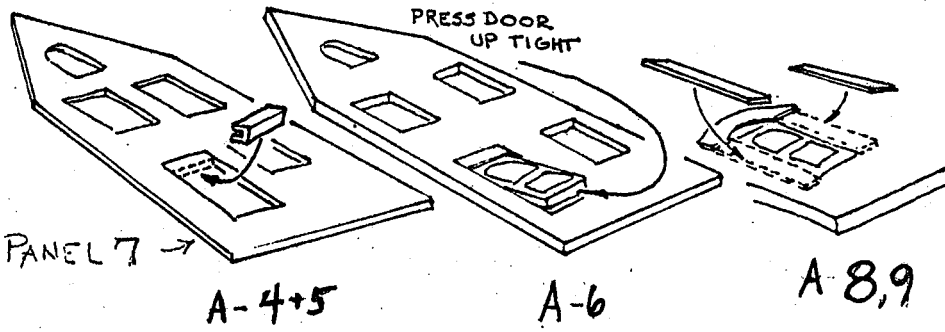

SECTION III

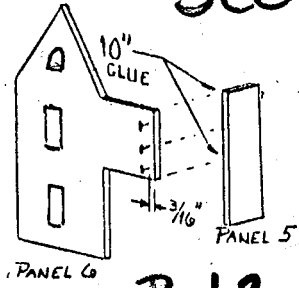

B-1,2

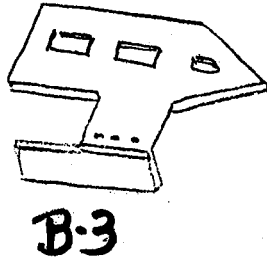

B-3

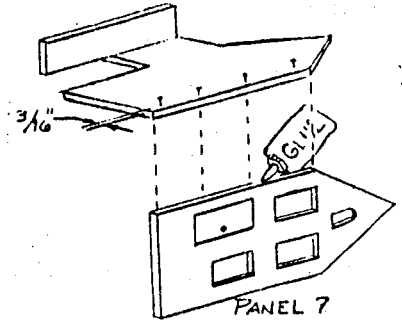

C

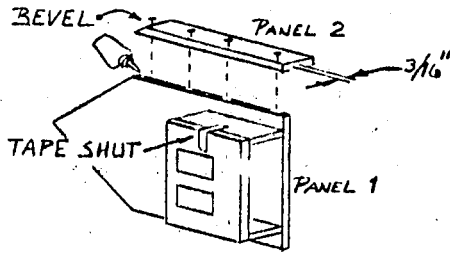

D

SECTION IV

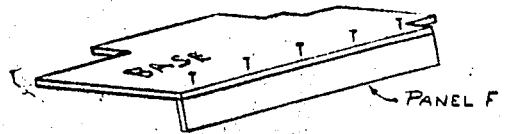

A 2-3

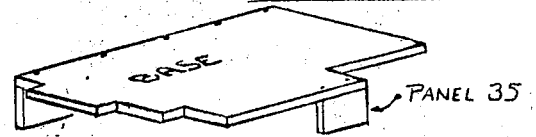

B 2-3

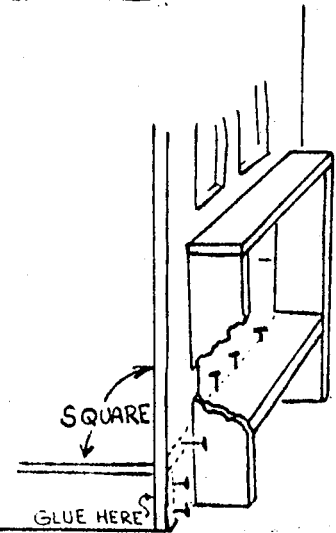

C-3-7

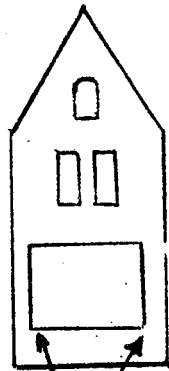

C-1

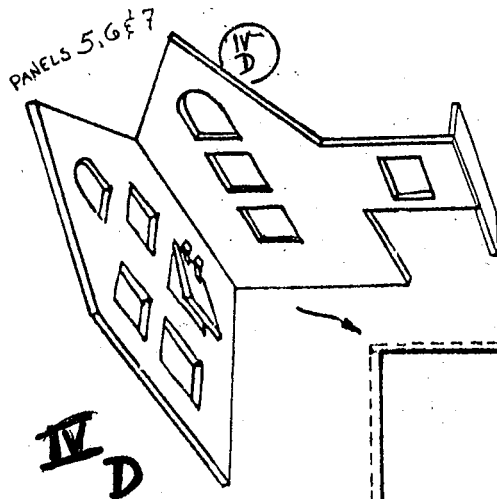

IV D

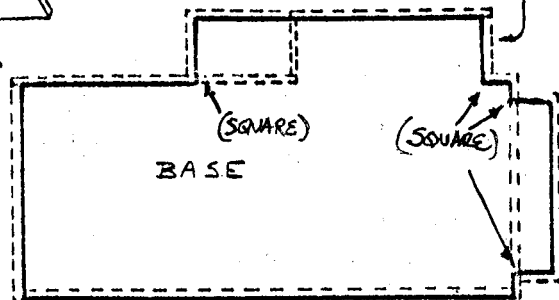
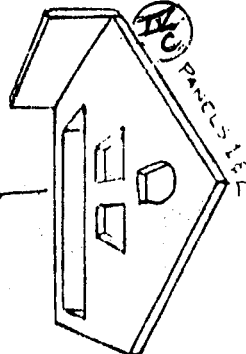
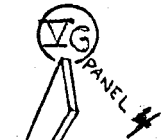
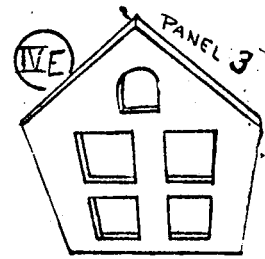

BASE

SECTION IV

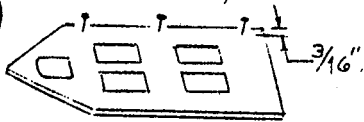

E-2

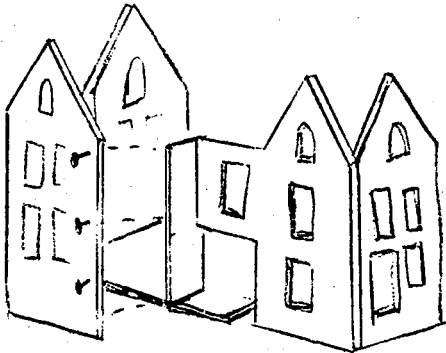

E-3-5

Section V

(A)

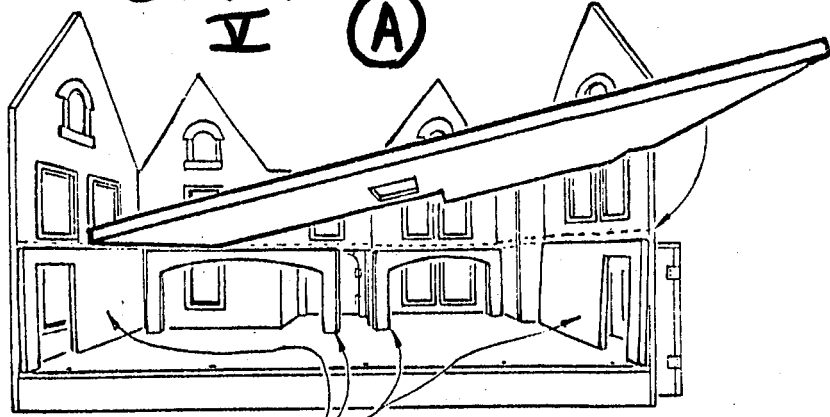

SET ROOM DIVIDERS HERE TO SUPPORT FLOOR TEMPORARILY WHILE NAILING IN PLACE

SECTION VI

Section V

(G)

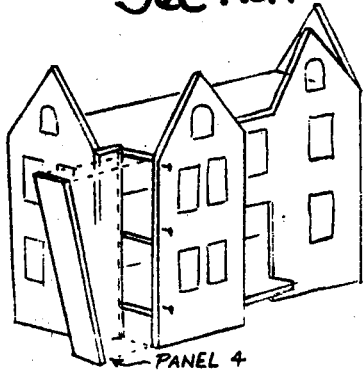

PANEL 4

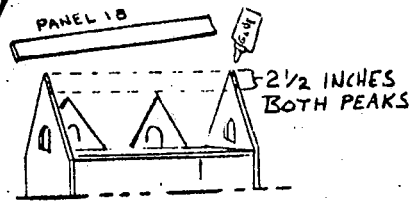

B-1



B-4

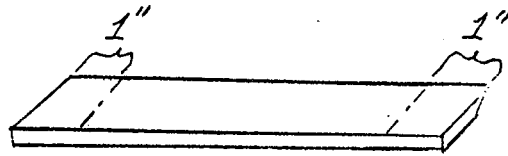

A-4

Section VII

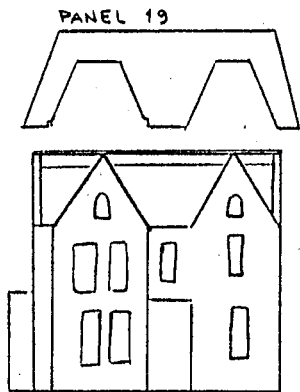

A-1

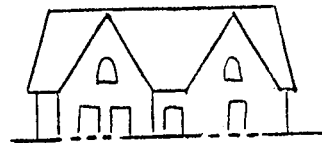

A-2

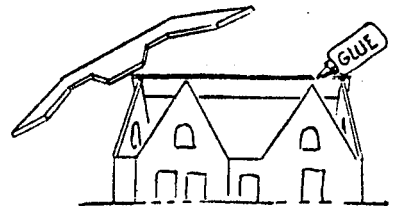

B-1

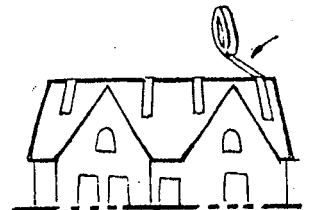
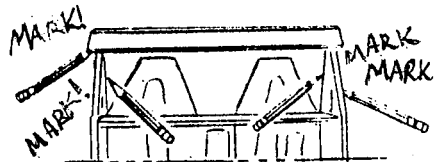

B-4

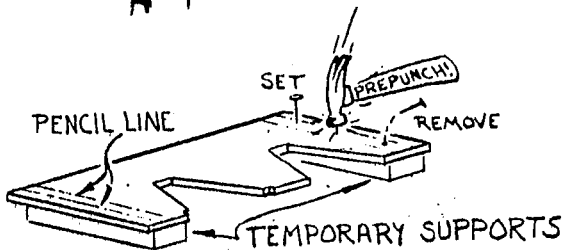

A-5

Section VIII

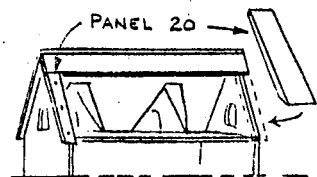

A-C

SECTION IX

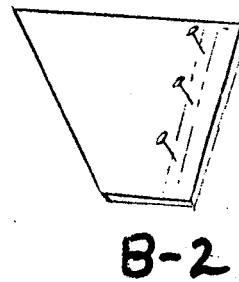
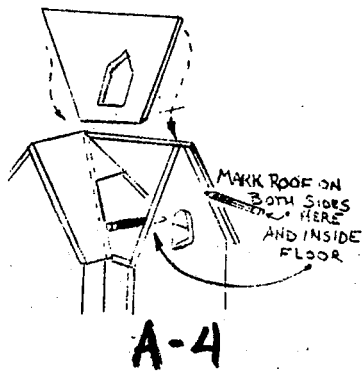
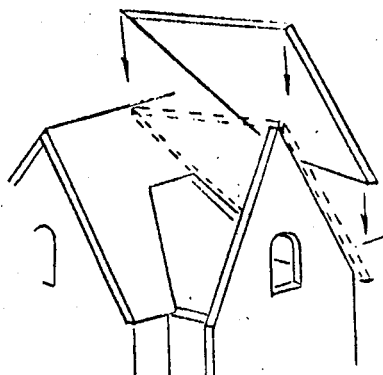

B-2

A-4

SECTION X

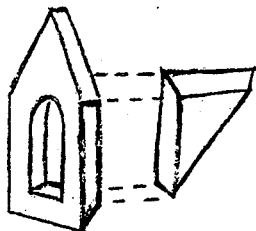

B-1

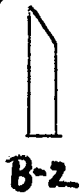

B-2

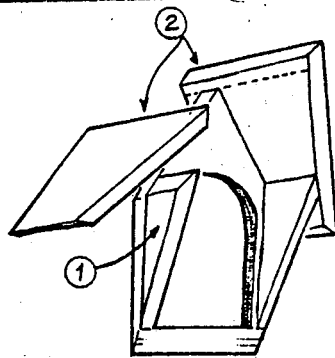

B+C

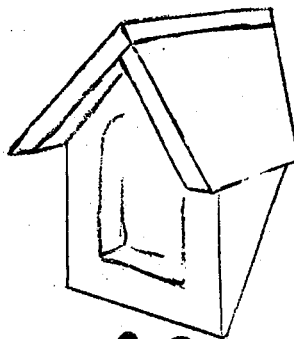

C-3

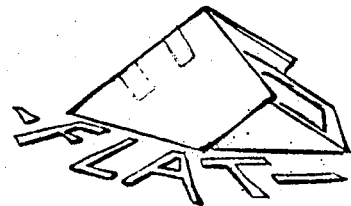

C-7+8

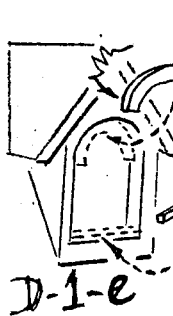
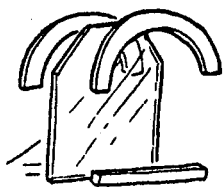

D-1-e



D-3

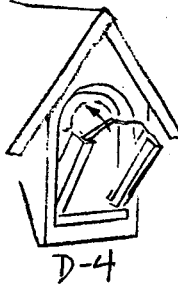

D-4

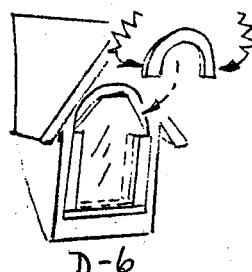

D-6

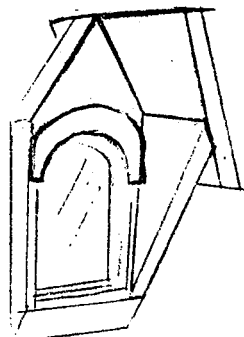

D-10

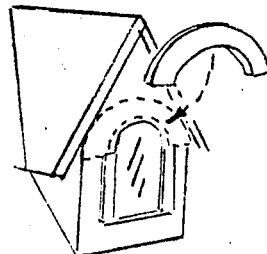

D-7

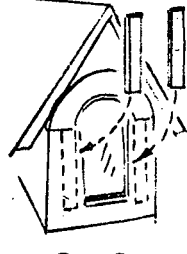

D-8

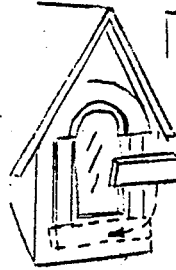

D-9

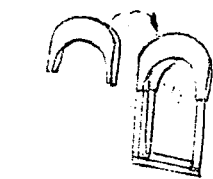

INTERIOR D-10

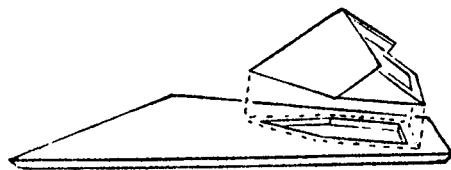

E-2-7

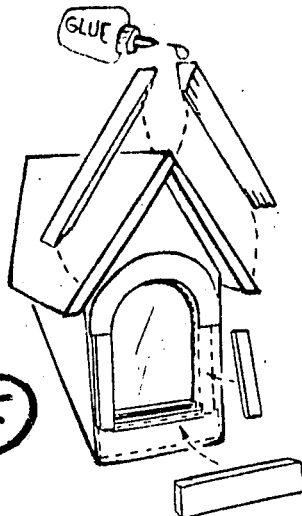

F

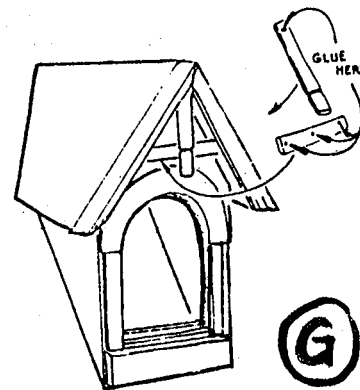

G

SECTION XI

A-8

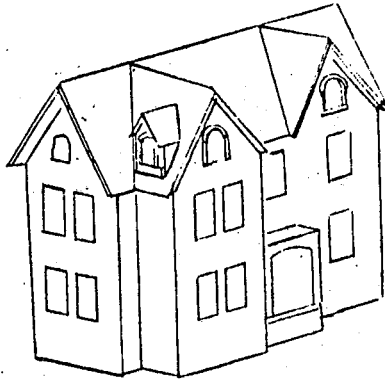
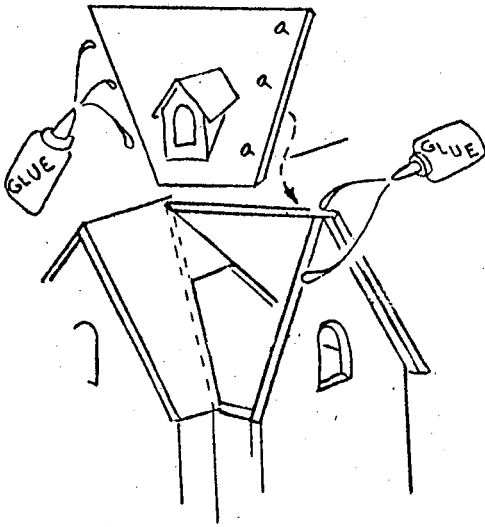

A-7

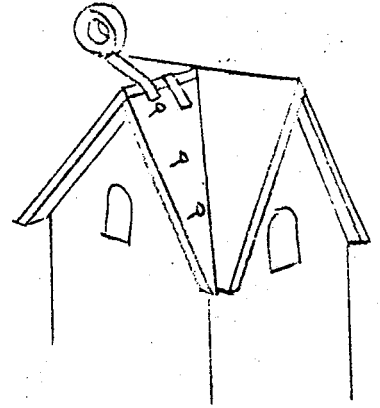

SECTION XII

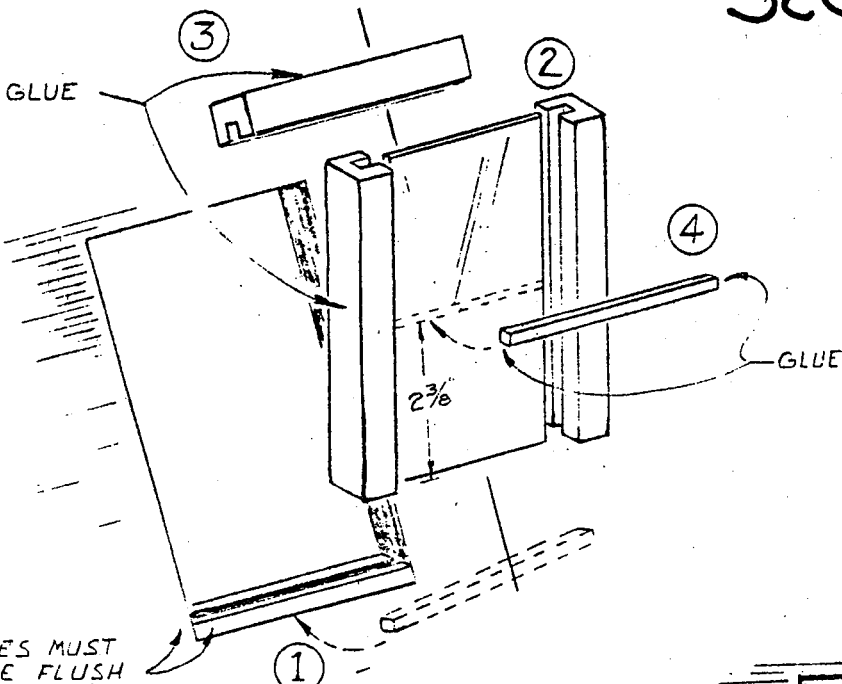

B-C

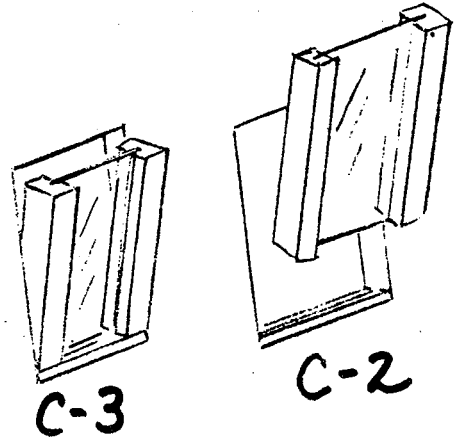

C-3

C-2

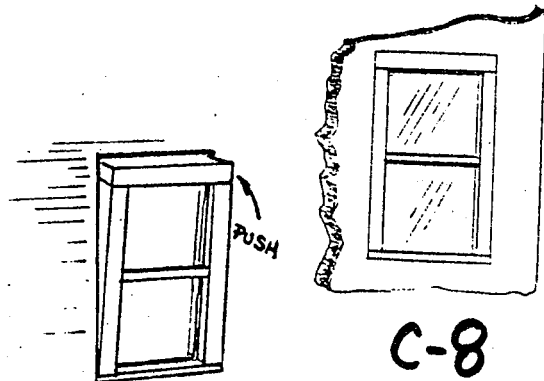

C-7

C-8

SECTION XIII

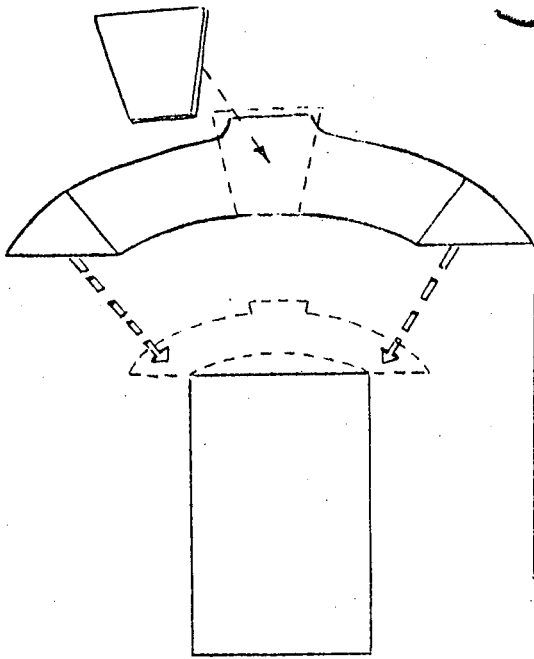

A 2-3

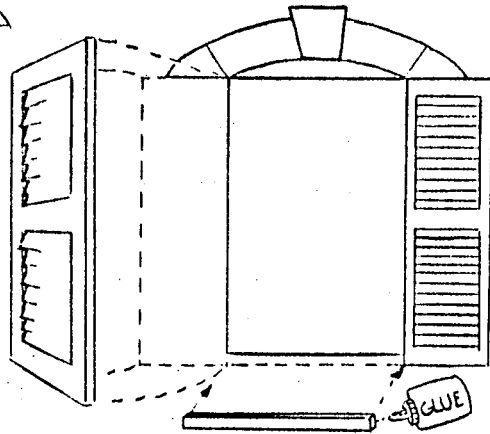

A-4+5b

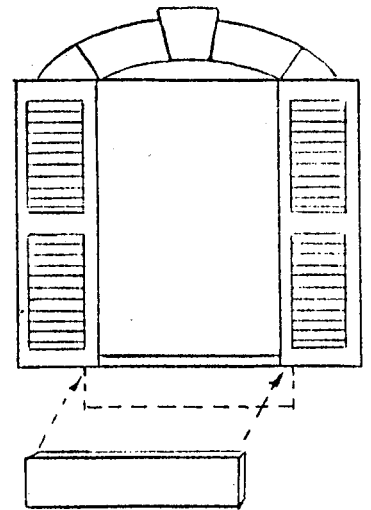

5c

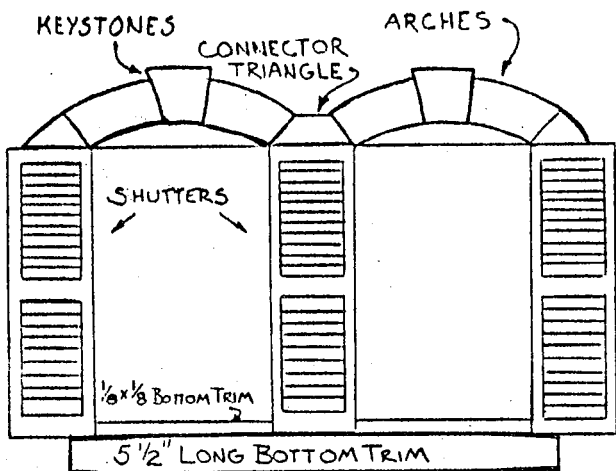

(B)

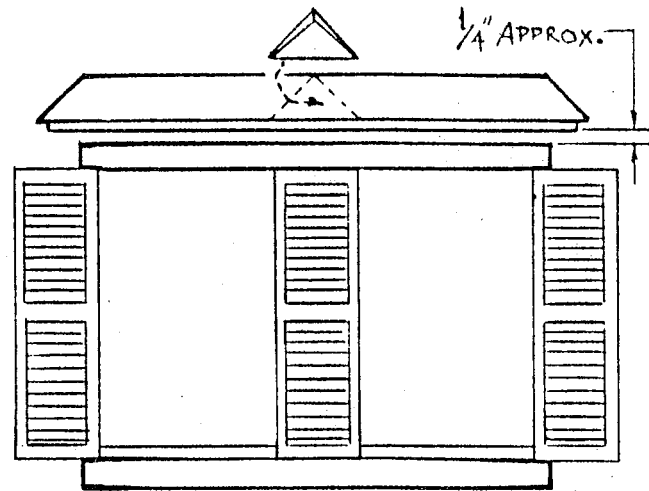

(C)

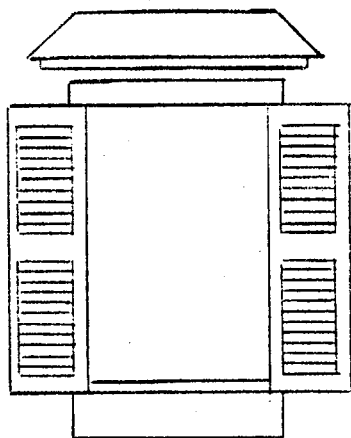

(D)

SECTION XIV

(B)

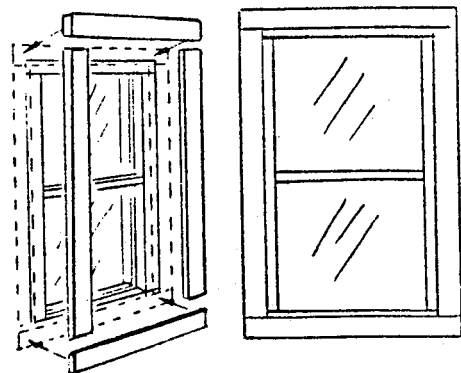

SECTION XV

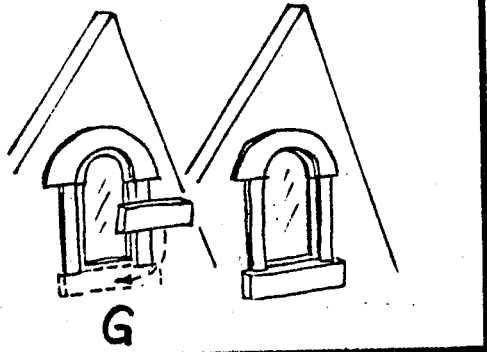
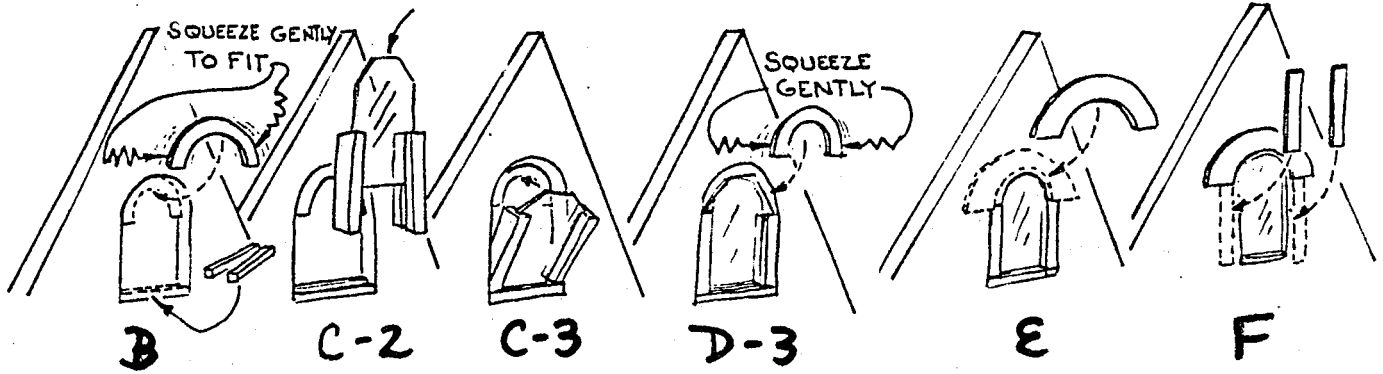

SECTION XVI

SQUARE OUT CORNERS

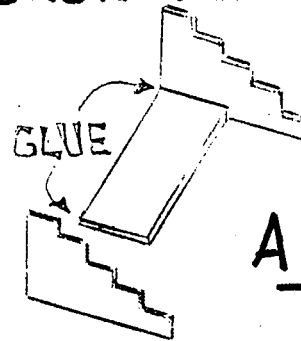
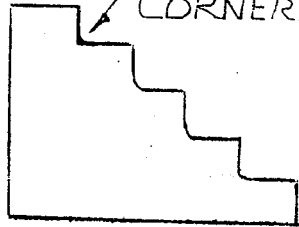

A

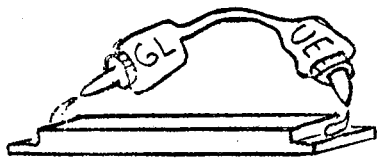

A-2

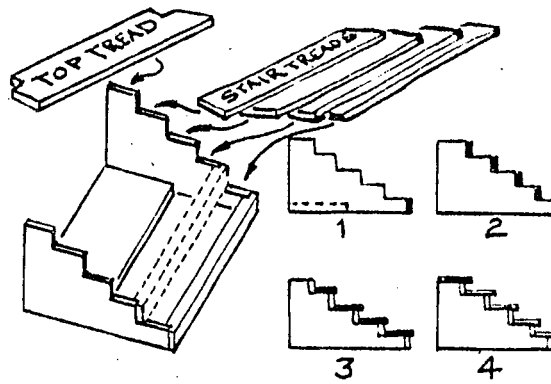
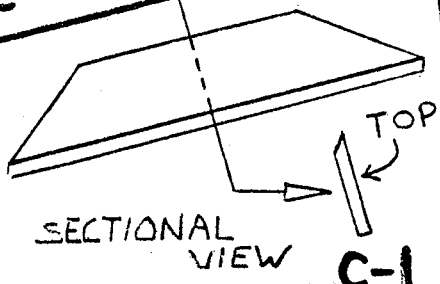

SECTION XVII

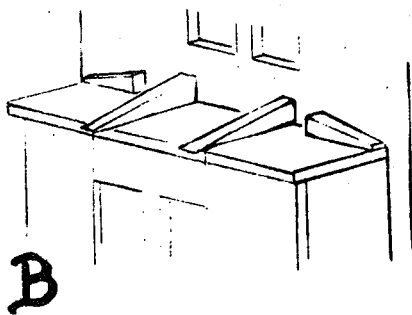

TAPE JOINTS TIGHT

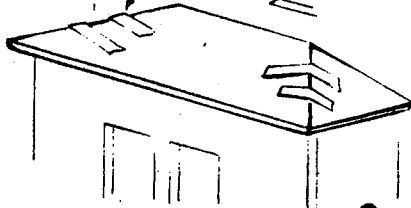

WOOD GRAIN CONTINUES IN SAME DIRECTION

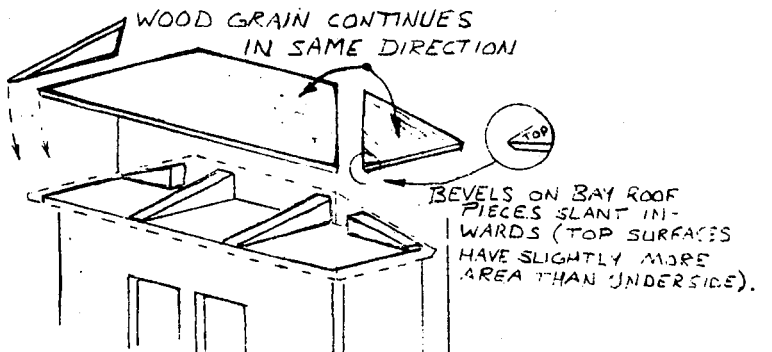

C-1

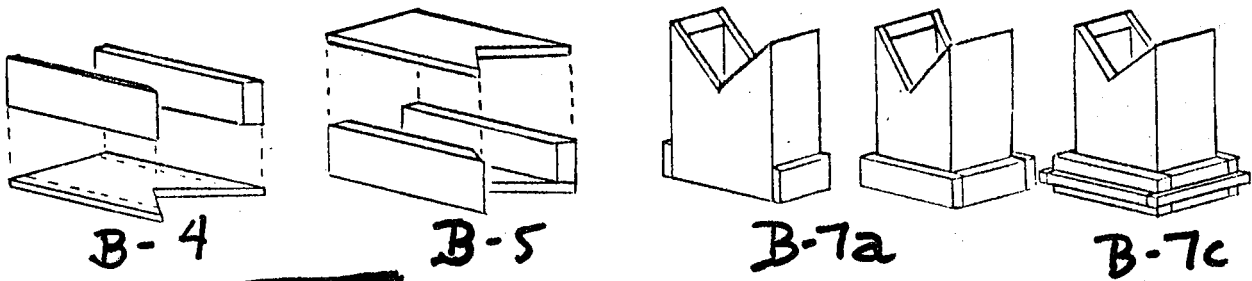

SECTION XVIII

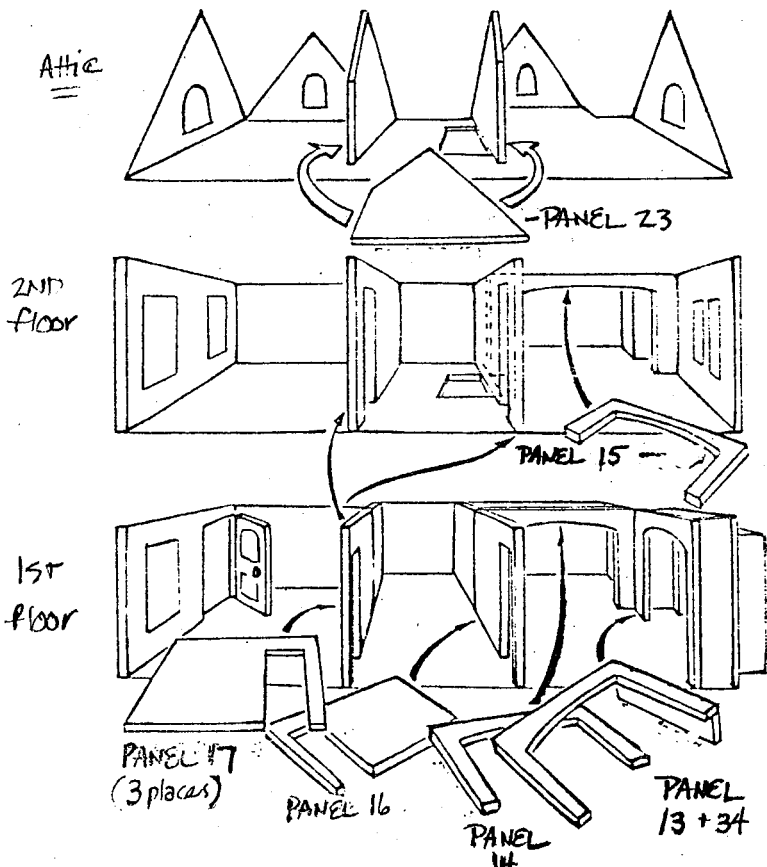
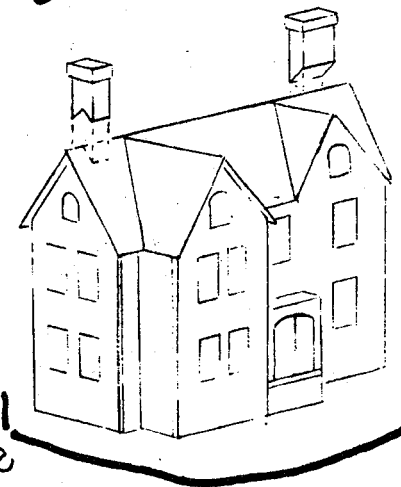
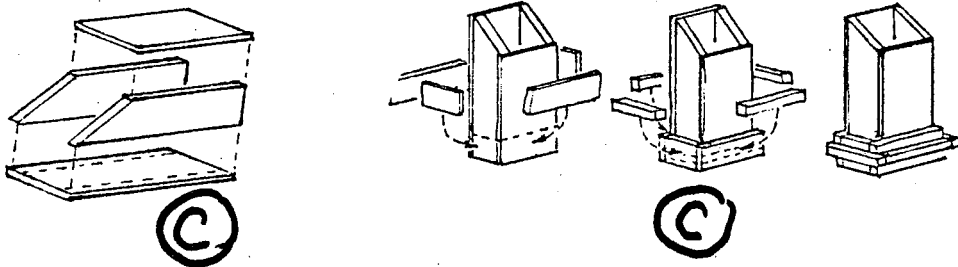

SECTION XIX

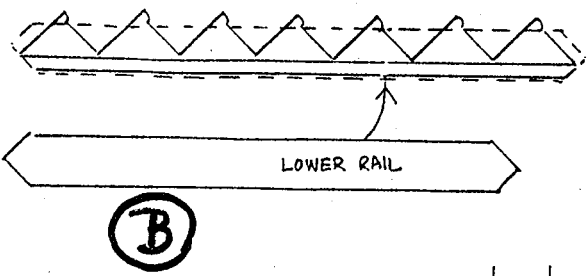

B

C-1

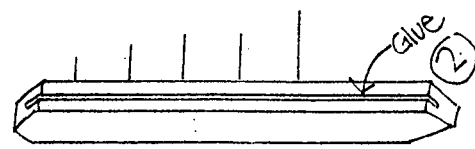

SECTION XX

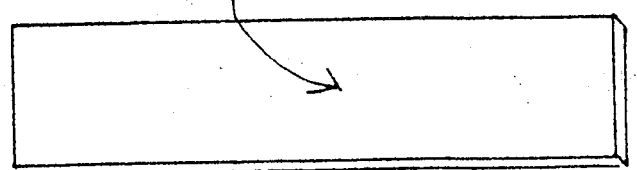

C-2

B-2

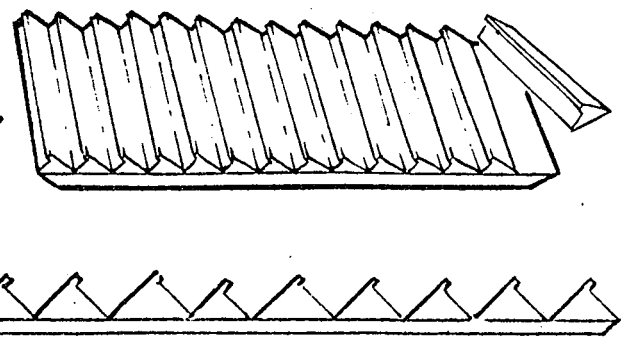

C-4

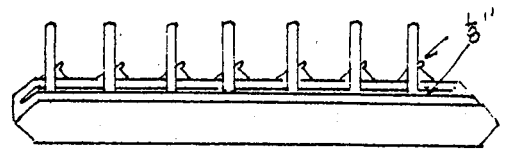

SECTION XXI

C-6

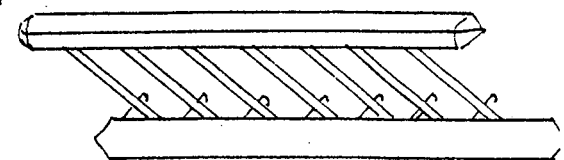
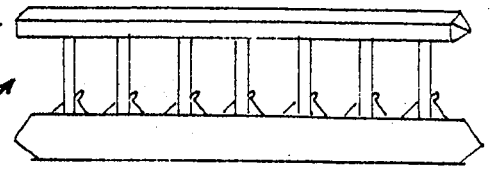

SECTION XXII

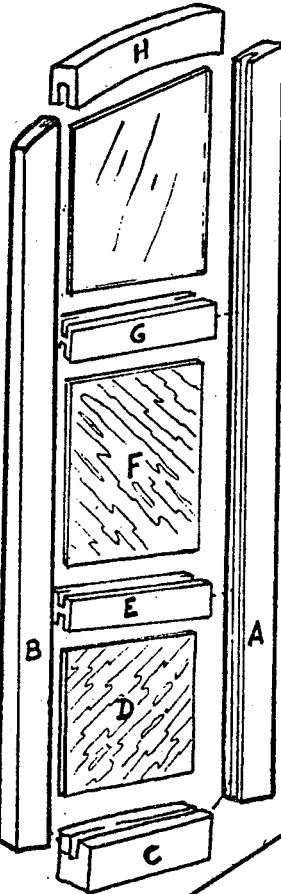
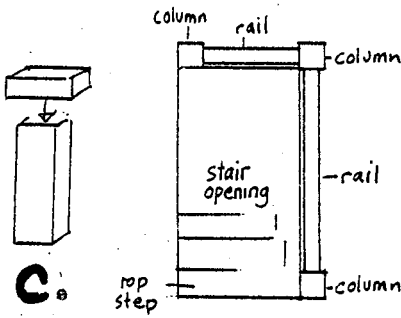
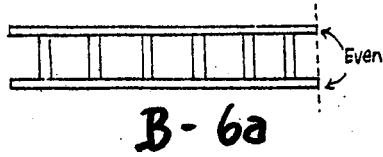
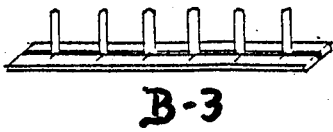
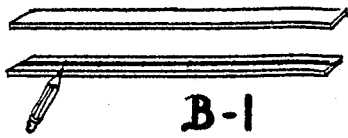

SECTION XXIII

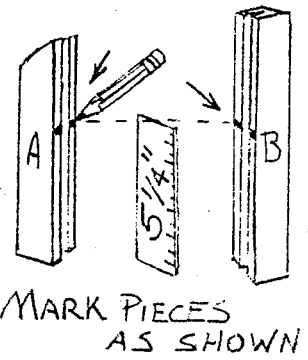
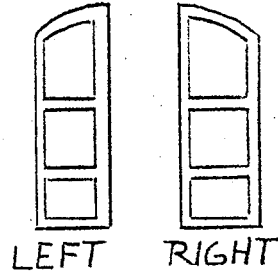

(A)

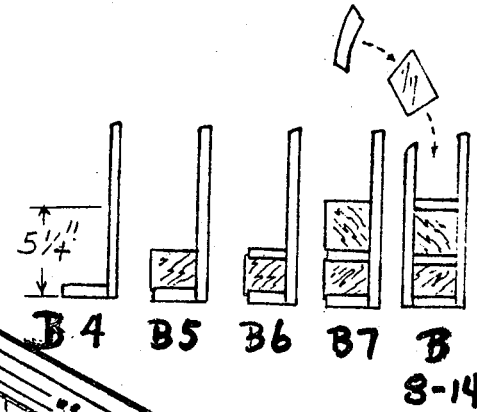

SECTION XXIV

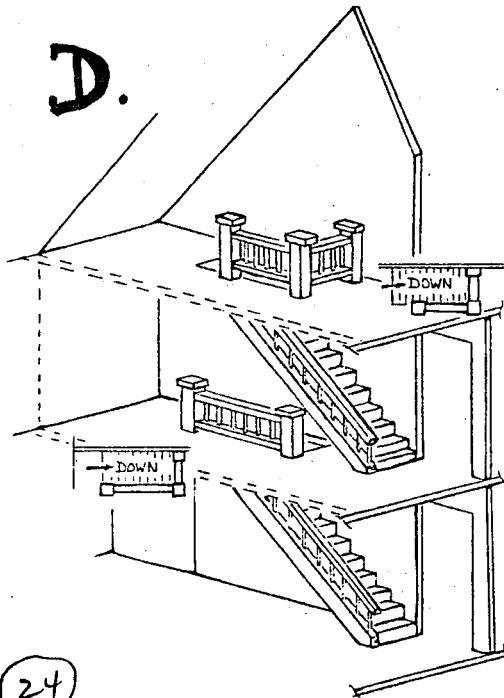
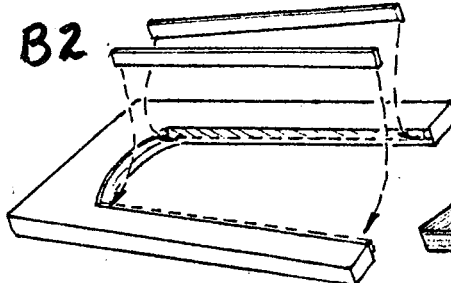
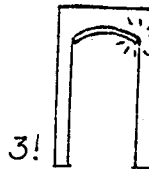
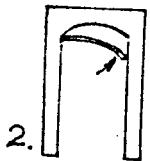
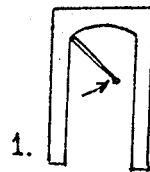
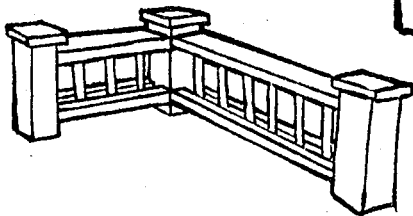
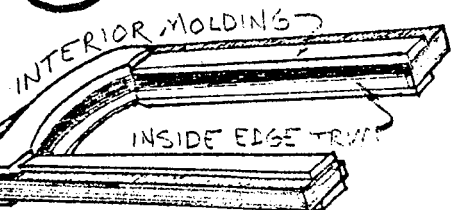
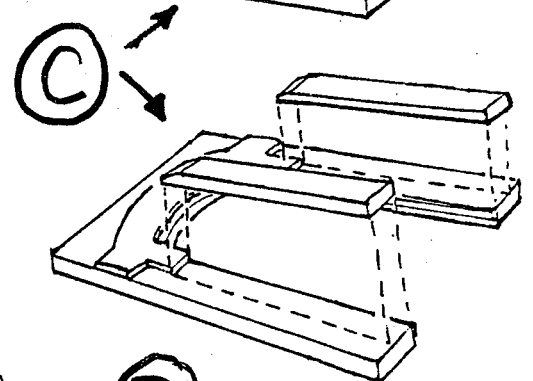
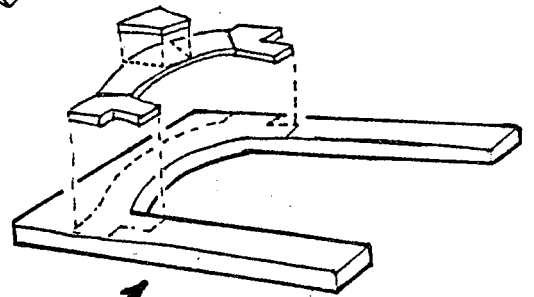
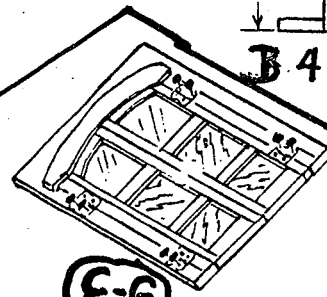

XXIV - G

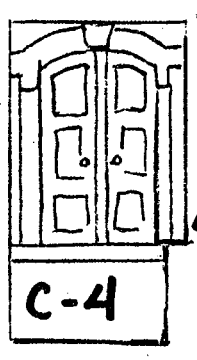
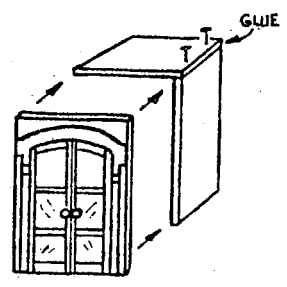
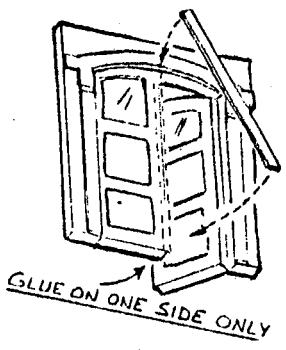

C-4

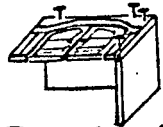

SECTION XXV

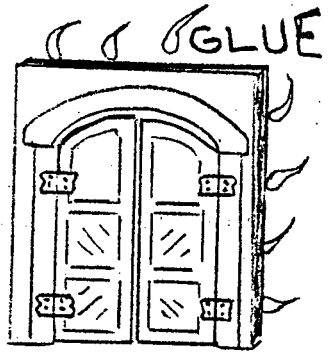

INSIDE VIEW C-1

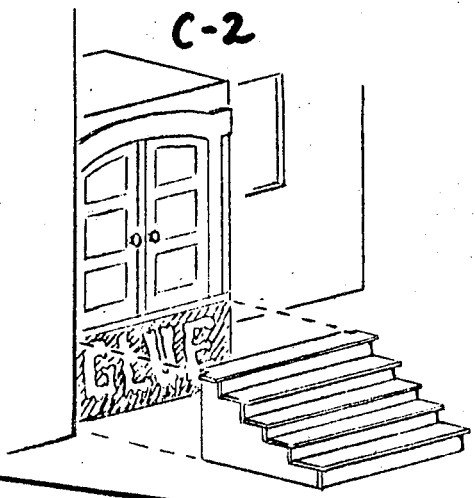

C-2

(A)

Steps 2-6

GLUE CORNERS FIRST

SECTION XXVI

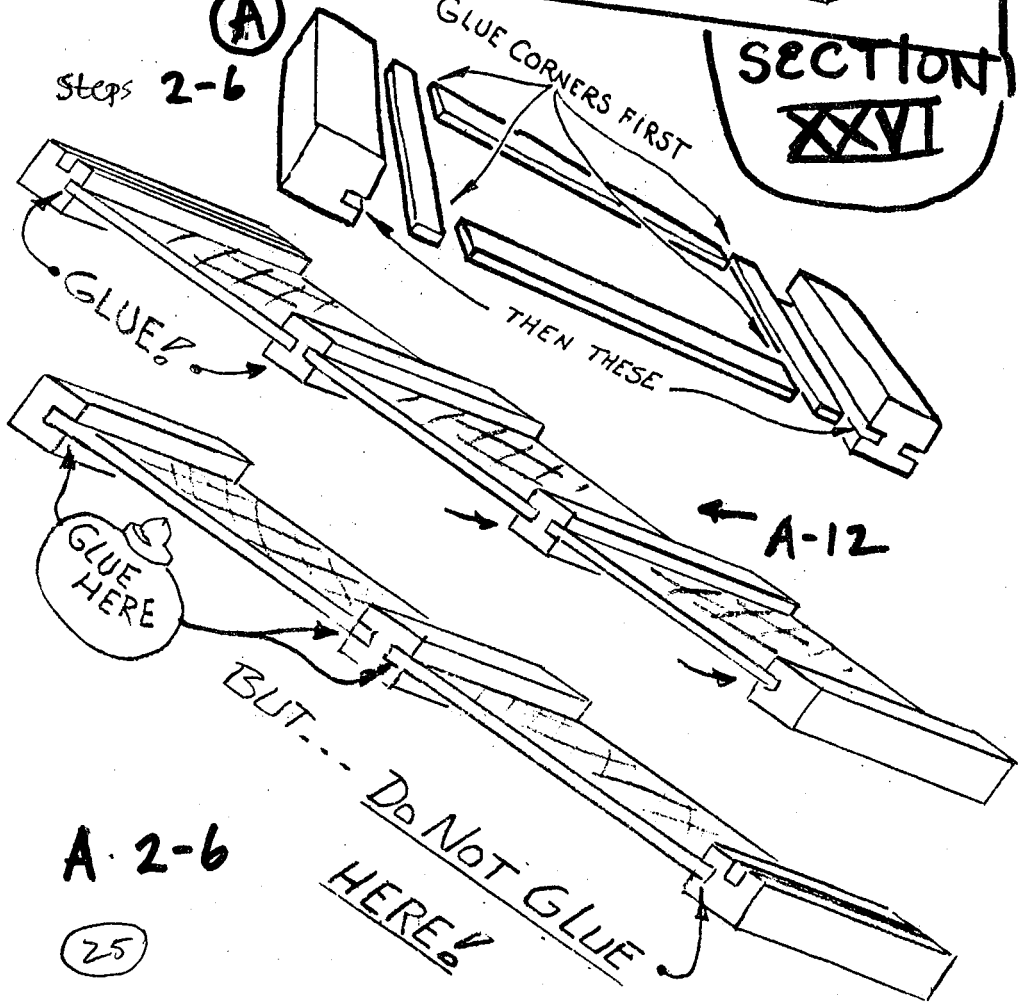

A-2-6

(25)

A-8a

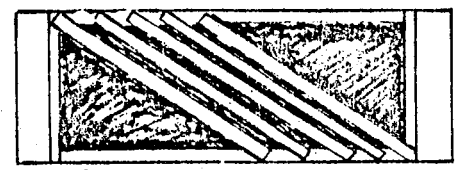
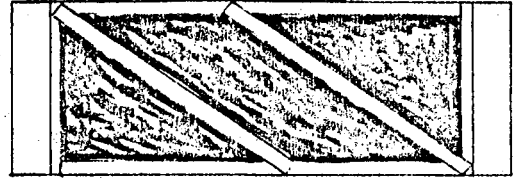

↑ A-8b, c, d



MARK LINES ON EITHER SIDE

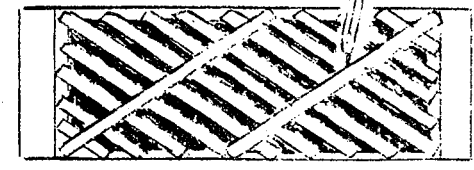

B-2

DABS OF GLUE



B-3

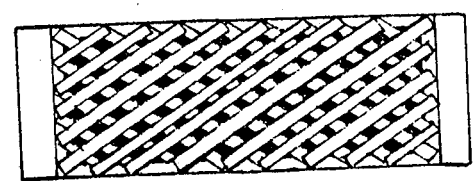

REPEAT IN OPPOSITE DIRECTION

B-6

SECTION XXVI

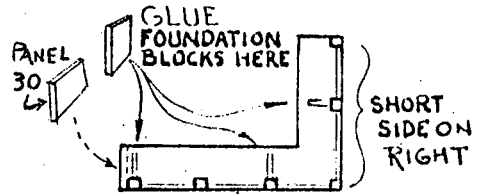
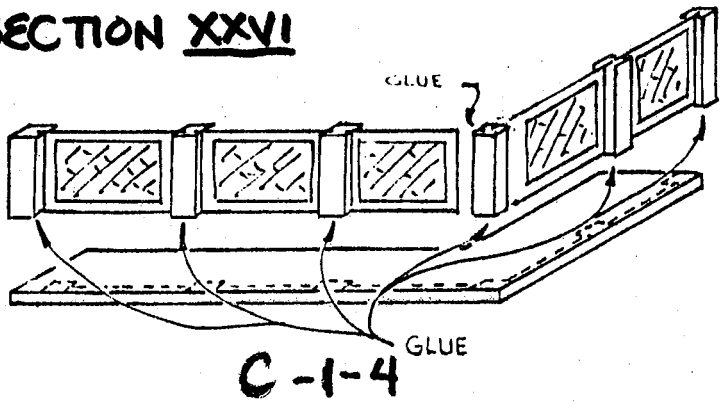

MAKE SURE YOU ORIENT PORCH FLOOR THIS SIDE UP TO ASSEMBLE

C-7.8

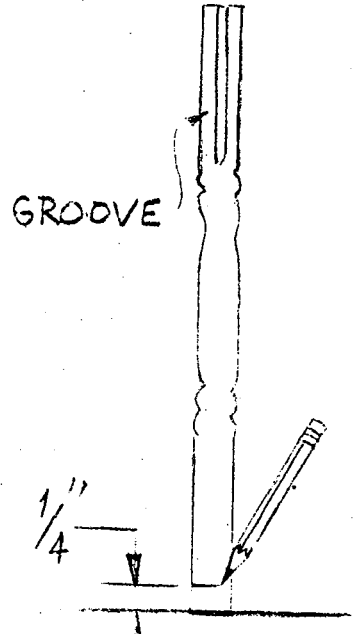
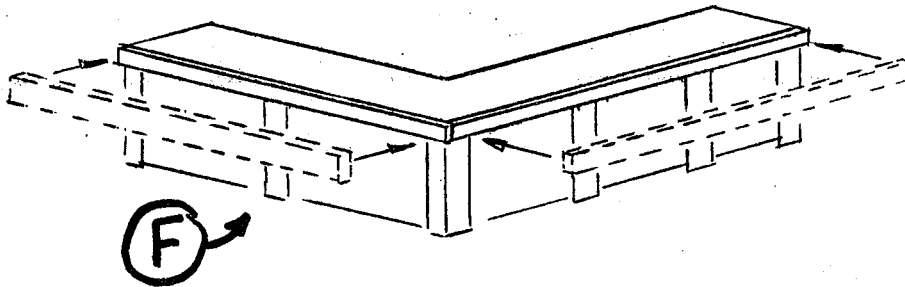
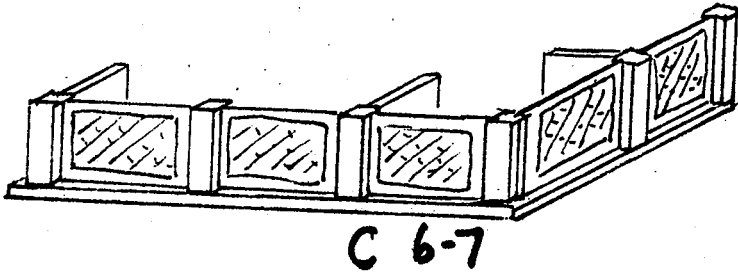

E-2

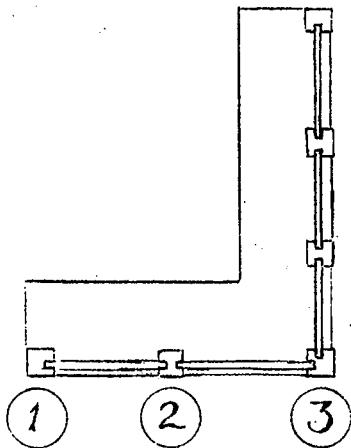

E-3

E-4

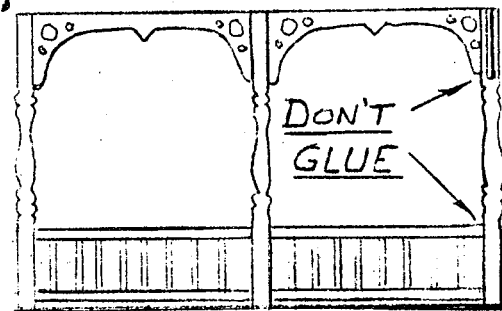

E

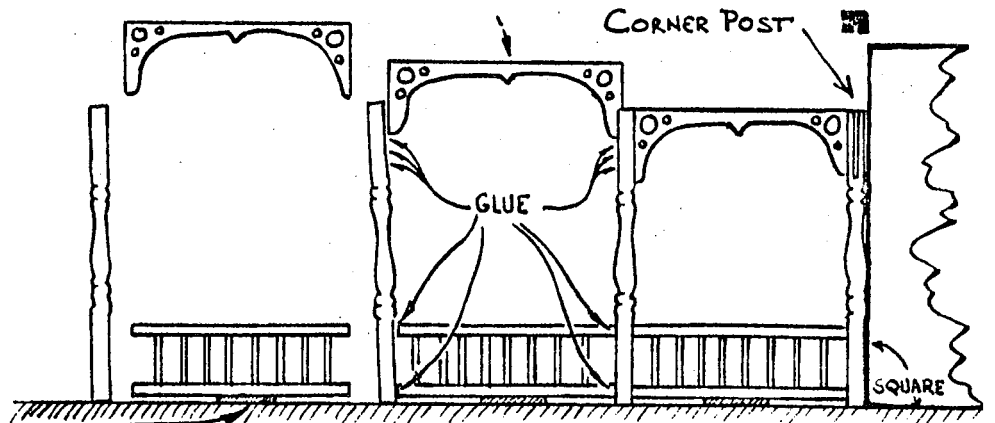

USE 1/4" THK. SPACERS TO SPACE RAILING ASSEMBLIES AT PROPER LEVEL WHILE GLUING.

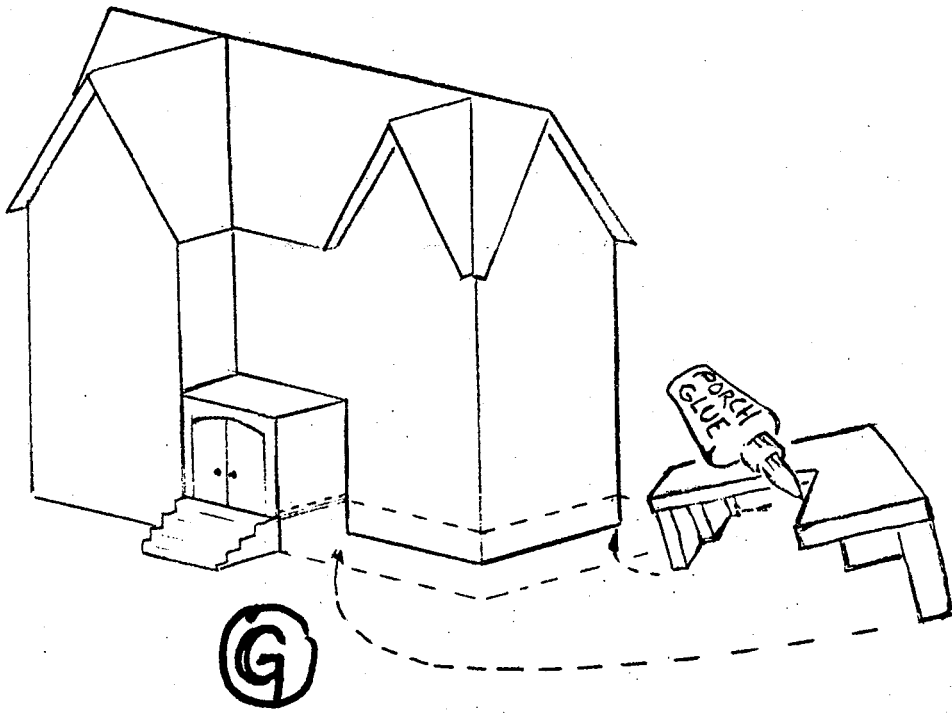

ASSEMBLE THESE SECTIONS SEPARATELY...

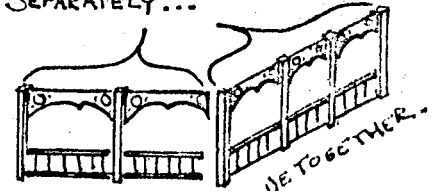

STAND UP AND GLUE TOGETHER...

I-1

USE PANEL NO. 27 TO KEEP PORCH RAILING SQUARE WHILE GLUING

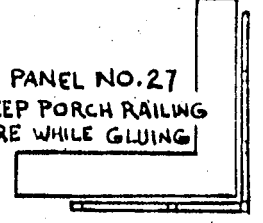

I-2

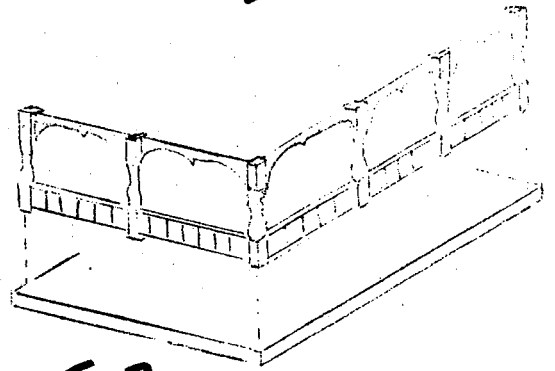

I-3

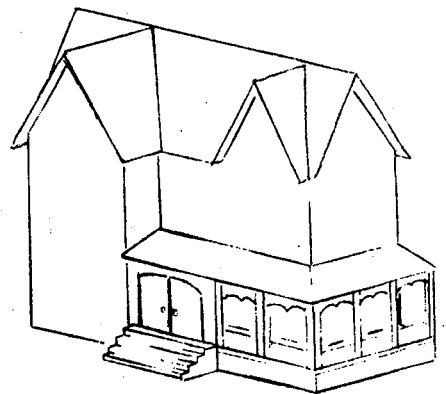
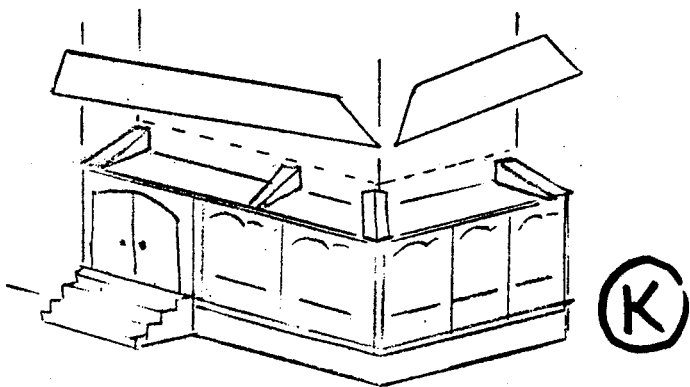
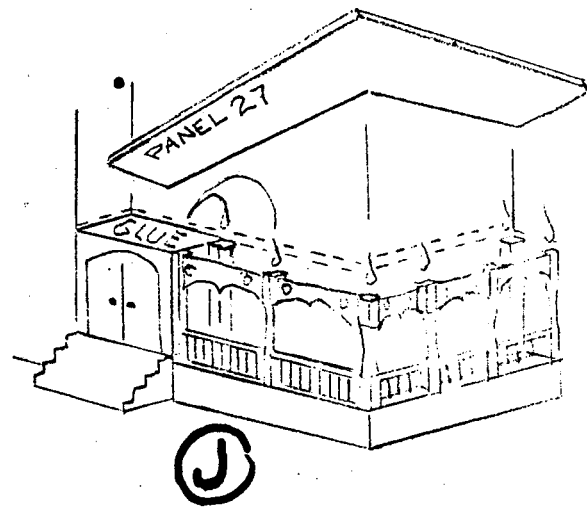
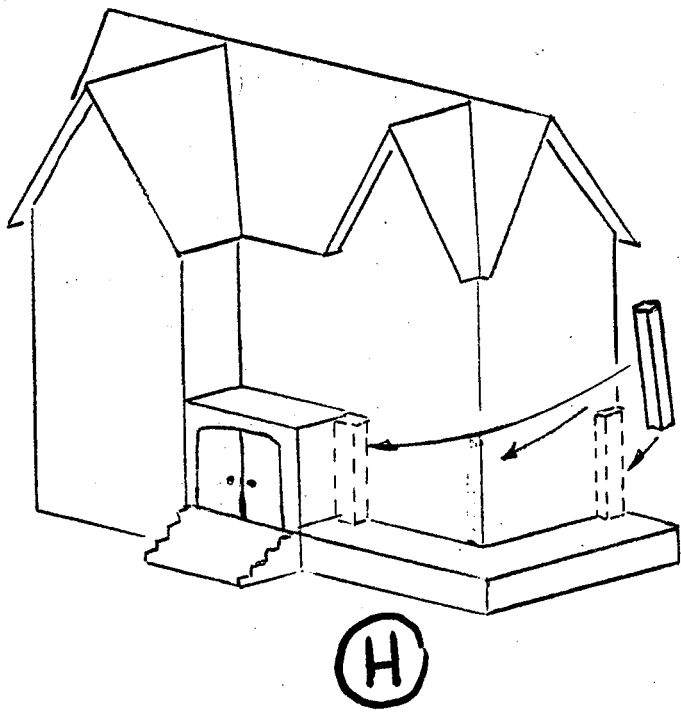

SECTION XXVII

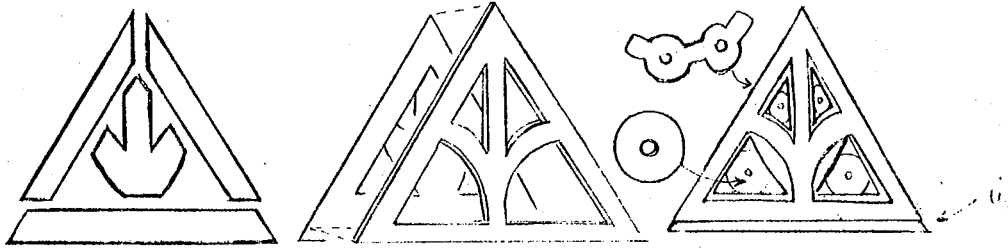

A-1,2,3

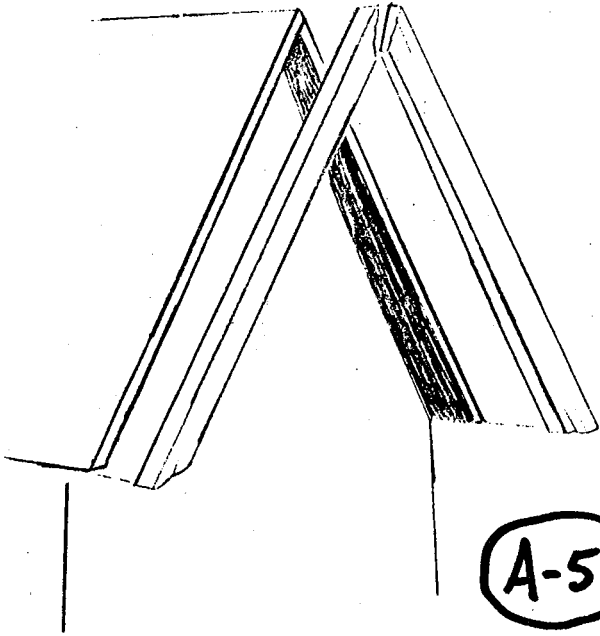

A-5

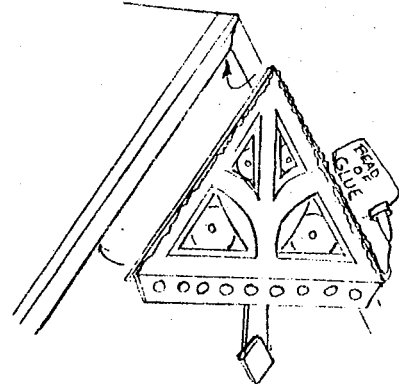

A-6

A-7

A-8

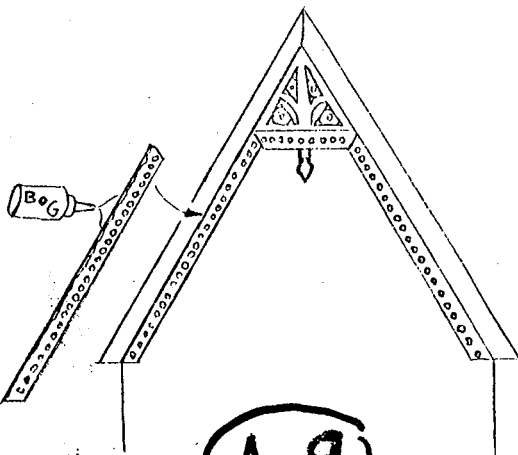

A-9

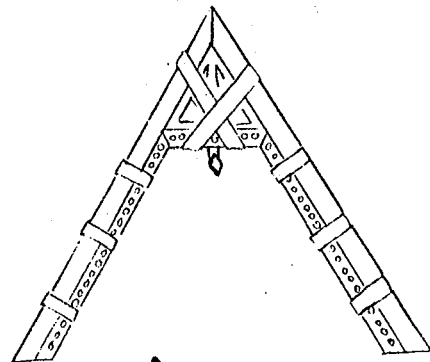

A-9d

A-9a

Miniature Dealer

October 1982

THE BUSINESS MAGAZINE SERVING THE MINIATURES TRADE

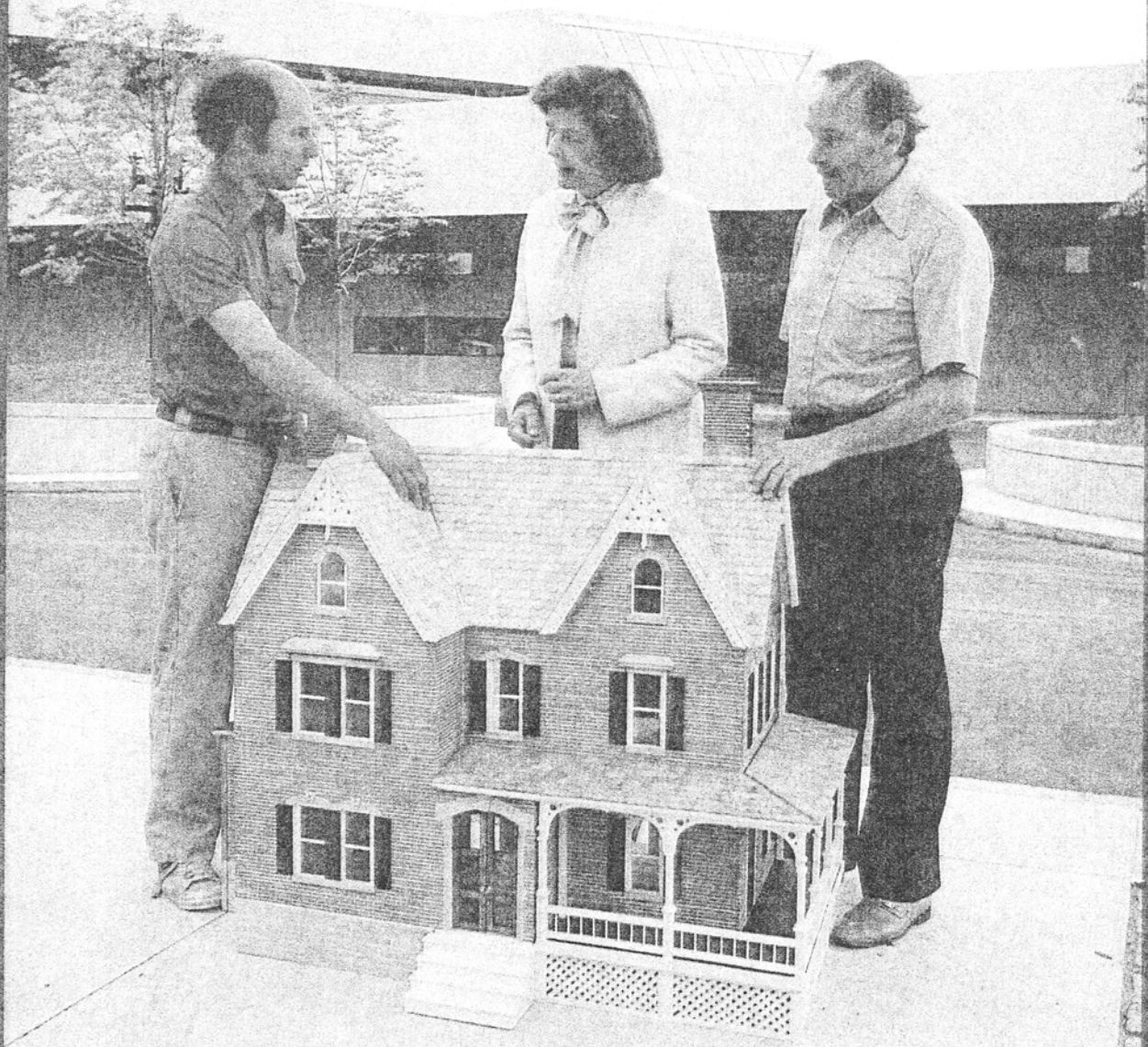

Margaret Woodbury Strong Museum Opens

**Plus: Getting a Bank Loan, Authenticity in Miniature,
Book Reviews & 14 Pages of New Products**