

No. 1009 Victorian

Inspired by historic Cape May, NJ, an authentic Victorian with open porches and balconies for ocean viewing. Three story tower with widow's walk and "Federal period" windows. Seven rooms including a "secret" tower room (layout similar to No. 1202 on page 4).

Overall Size: 19" x 43" x 35" Ship Wt. 40 lbs.

INTRODUCTION: To quote an old adage "If it's worth doing at all, it's worth doing right".

You are about to begin the process of constructing a scale model Doll House that is destined to become an heirloom in your family. When it is completed, it will reflect your own careful skills and patience. It will be a labor of love; an accomplishment to be viewed with pride!

There are many parts in this kit; all of which have been carefully pre-cut and packaged in units to simplify their identity and assembly. You should become familiar with the parts by reviewing the Parts Lists and diagrams on the last few pages of these Instructions. Go through the various parts and identify them.

Read all Instructions thoroughly before beginning assembly!

Proceed step-by-step through the assembly process. DO NOT skip steps. Read the entire instructions of any Step before starting and pay particular attention to the "Hints" outlined in the Step.

Work methodically; carefully; and slowly!

MATERIALS NEEDED Assemble the following materials before starting:

- | | | |
|-------------------------------|----------------------|-----------------------------|
| 1. White Wood Glue | 6. String | 11. Razor Knife |
| 2. Tape Measure | 7. Masking Tape (1") | 12. Soft Cloth or Sponge |
| 3. Yardstick or straight edge | 8. Wax Paper | 13. Weights (such as books) |
| 4. Pencil | 9. Sandpaper | |
| 5. Heavy Rubber Bands | 10. Scissors | |

HELPFUL TOOLS The following tools are not required but may be helpful:

1. Small coping saw or hack saw
2. Carpenter Square
3. Fine file or emeryboard
4. Small C Clamps or Spring Clamps
5. Spring type clothes pins
6. Electric Glue Gun

GENERAL HINTS

Gluing Chose a white glue with quick tack (quick-setting) properties. Model Homes brand "Doll House Builders' Glue" has been specially formulated for wood doll house construction and is our recommended. However, you may use any quality wood glue.

Use glue sparingly, unless directed otherwise. Always wipe-up excess glue with a damp cloth or sponge, before it dries.

For certain steps (such as applying roof shingles) a hot-melt electric glue gun is a great time saver.

Sanding It may be better to sand parts before assembly, depending on the finish you desire on the completed house. To sand flat surfaces, make a sanding block by wrapping sandpaper around any block-size part such as one of the porch steps or chimney parts. Specific sanding hints are included in several steps in the instructions.

Filing In some steps the use of a small file or emery board is indicated to remove larger amounts of wood such as in notching, or mitering of mouldings.

Painting It may be easier to pre-paint some parts before assembly. Window shutters, for example, are best painted before gluing onto the siding. If you decide to pre-paint parts before assembly, make sure that you leave gluing surfaces unpainted. Glue adheres better to raw, unpainted wood! Read the instructions under "Finishing Touches" in the back sections of this instruction booklet.

Dimensions The dimensions shown on the parts list are approximate and the actual part may vary slightly from the size as printed. This is due to dimensional tolerances in cutting wood. Where important, parts will be no more than plus or minus 1/32 inch. For other parts, where size is not too important (such as in the length of handrails for stairs) tolerances up to 1/8th inch are allowed. As with all wood hobby kits, some sizing by the hobbyist (by trimming, or sanding, etc) may be required.

Part Number Codes:

- A--Clapboard Siding Sections
- B--Window & Door parts
- C--Base & Foundation Parts (Particle Board)
- D--Floors, Partitions, Roofs (Hardboard or plywood)
- E--Trim, Frame, Molding parts
- F--Stairway Parts & Railings
- G--Shakes & Shake Trim moldings & ornaments
- H--Porch & Balcony Parts
- J--Chimney Parts
- K--Dormers

HOW TO IDENTIFY PARTS

The parts in this kit are of four types:

1. Bundles of moldings, such as siding.
2. Bags of small parts
3. Die-Cut sheets
4. Panels of plywood, fibreboard or hardboard.

As directed in the Introduction to these instructions, you first task is to sort and identify all parts. By referring to the parts lists and diagrams which follow and by using a ruler to measure sizes, proceed to identify each part. Check off each part on the list as you find it and verify that sufficient quantity has been received. Suggestion: lightly mark part numbers with pencil on larger parts; sort smaller parts into paper cups, egg cartons, etc. and mark the containers with part numbers. Caution: Keep all parts contained within a bundle or bag together since since these packages contain common parts used in one assembly step, such as a staircase or dormer. DO NOT MIX these packaged parts!

You will note that the parts list is organized into the same four types of parts listed above. The contents of each bundle or bag are listed together.

If you have read & understood all instructions and you have separated and identified all parts, you are ready to proceed.

STEP 1. BASE & FOUNDATION ASSEMBLY

Cover your worktable with waxed paper, taped together with masking tape, so that glued parts will not adhere to work surface.

Locate all particle board base parts (C-2; C-3; C-4; C-5; C-6) and arrange as shown in drawing. Note that parts C-2; C-3 and C-4 are glued together on edge to form one large panel. Parts C-6 are inside the "box-like" structure formed on top of this large panel.

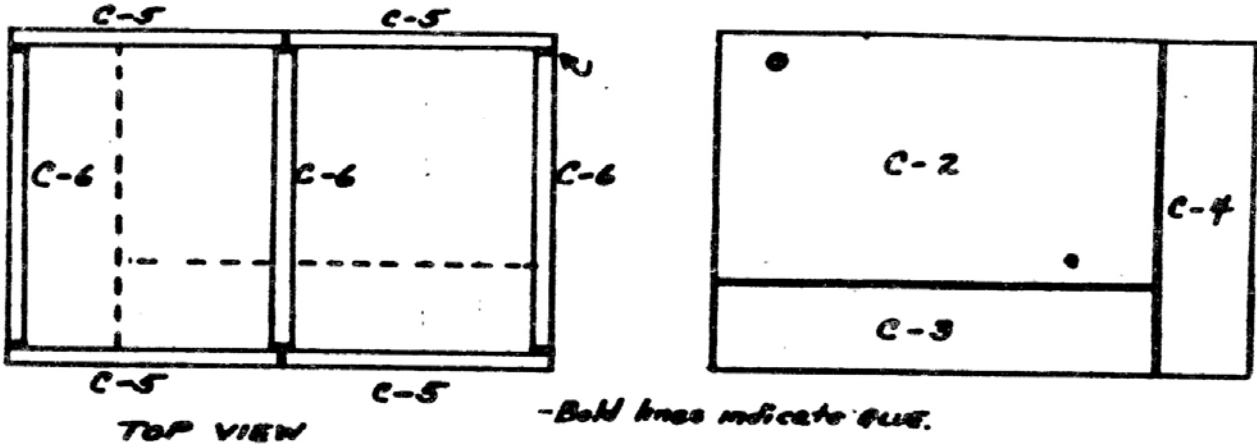

Proceed to make the large panel by gluing C-2; C-3 and C-4 together as shown. Apply side pressure and top pressure (with weights) until glue has set. Keep assembly square and flat.

Apply liberal amount of glue to longer edge of parts C-5 and C-6. Also apply glue to one end of C-5 and both ends of C-6. Arrange these parts as shown on top of the large panel made above. Square-up assembly; apply side and top pressure (weights) and set aside to dry.

STEP 2. WALL ASSEMBLY

The basic walls are made up of 12 pieces of tongue/grooved clapboard Siding (each piece of siding has three simulated clapboards). Study a piece of siding to become familiar with the tongue edge and the groove edge. NOTE: the tongue edge always faces up and the grooved edge always faces down. Walls A, B, G, H are 12 pcs; walls C-D-E are 17 pcs.; and F is 5.

Carefully arrange (with out glue yet) all siding parts according to the diagram. Note that each line in the drawing represents one section of siding. Measure siding parts with tape rule to make sure of their identity (Remember the General Hints on Dimensions--slight variations in siding lengths (up to 1/8") due to cutting tolerances are not important since corner posts and window casings will hide them.).

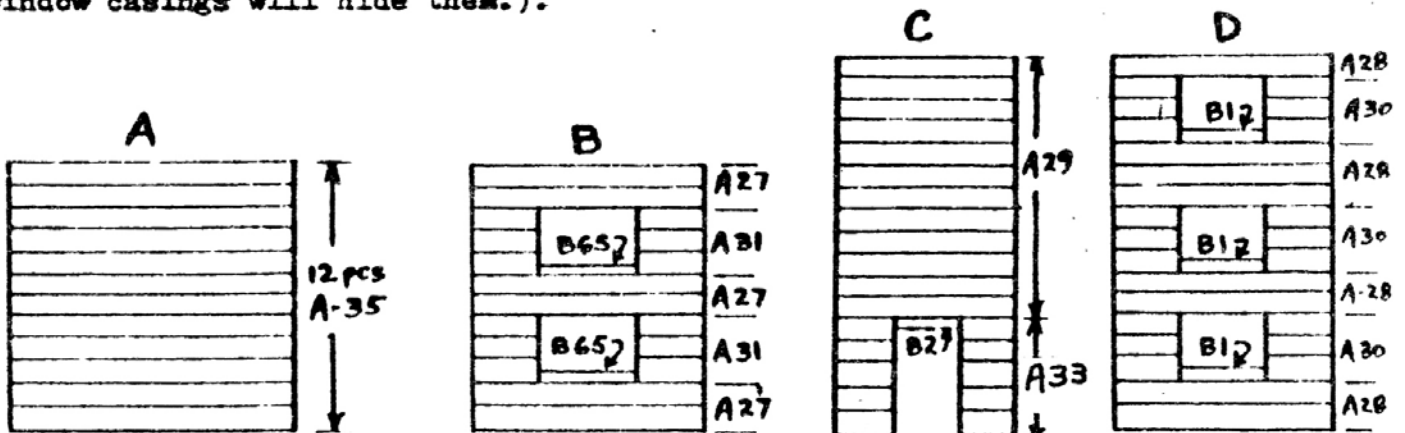

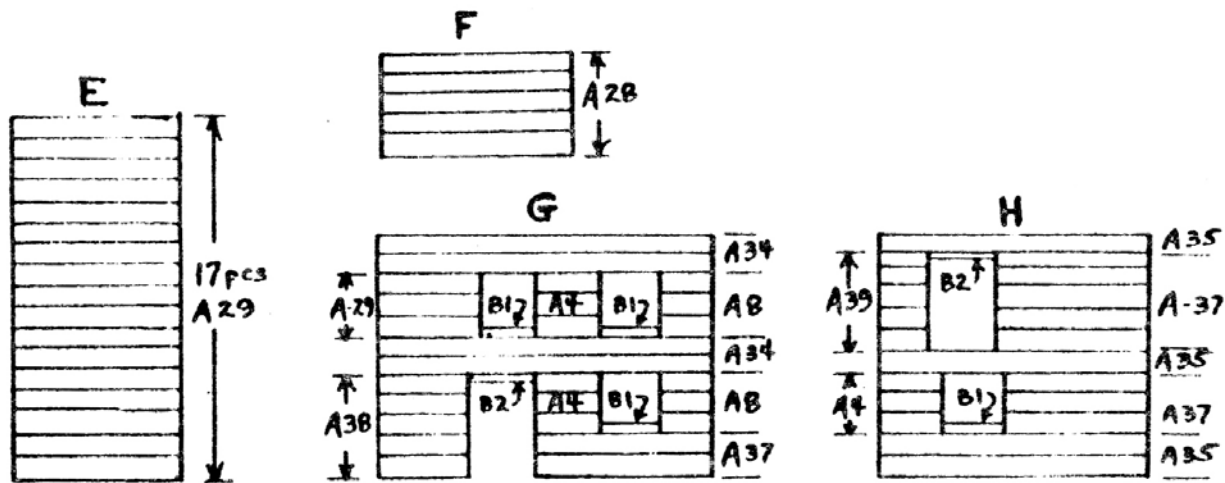

Locate window spacers (Parts B-1; B-65) and door spacers (B-2) and include them in your arrangement as shown.

Again, cover your flat work surface with clean waxed paper.

All wall sections are assembled by first gluing together smaller sub-assemblies of 3 pieces of siding. After glue dries, these sub-assemblies are glued together to form walls, with spacer parts installed for window and door openings. Use rubber bands to squeeze siding tightly together as you assemble the 3 piece sub-assemblies; and also, use weights to keep flat and square. **NOTE:** So that the inside walls will be as smooth as possible for wallpapering or painting, press down on siding as you assemble it to keep it flat!

Also, make sure that siding sub-assemblies and the full wall sections are square. Keep window and door openings square too.

Proceed to assemble all wall sections.

STEP 3. INSTALL CORNER POSTS

Study the illustration which shows a top view (looking down into house) of wall panels and corner posts assembled. Be sure to note the differences between cornerposts (E-45; E-46; E-47; E-48) and the differences in the positioning of the grooves in the cornerposts.

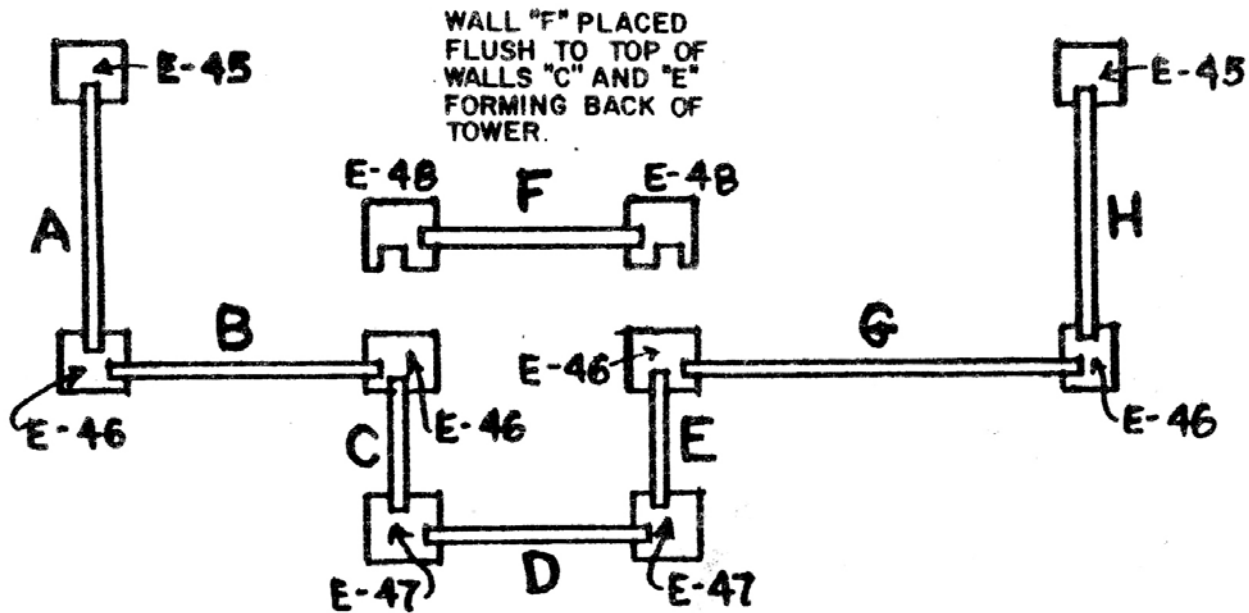

Inspect all cornerposts and, using sandpaper, clean grooves of all splinters or shavings. Cornerposts are made slightly longer than needed and will be trimmed in a later step. If edges have become split or broken in shipment, they can be re-glued in place at this time. If end is slightly chipped out, position it upwards (towards top of wall) for trimming later.

Next, inspect your wall panels. Make sure walls are free of dried glue droplets and are square overall. Sand off excess glue and true-up squareness by sanding with sanding block if necessary. Test for fit into cornerpost grooves; if too snug, sand groove in cornerpost or sand away some of the clapboard near edges.

Pre-assemble (no glue) cornerposts on the following wall panels:

- Wall "A" with one E-45 cornerpost.
- Wall "B" with two E-46 cornerposts.
- Wall "D" with two E-47 cornerposts.
- Wall "G" with two E-46 cornerposts.
- Wall "H" with one E-45 cornerpost.
- Wall "F" with two E-48 cornerposts.

Make sure grooves in cornerposts are positioned as shown in drawing.

IMPORTANT: Remember when positioning walls, that the tongue edge of siding points up and the grooved edge down!

After trial pre-assembly without glue, apply a bead of glue to grooves in cornerposts. Secure cornerposts to wall panels with wide rubber bands. Make sure cornerposts are flush with bottom of wall panels. The alignment at top is not important since it will be trimmed later. Also, make sure the wall panels fit all the way into the grooves.

Wipe up excess glue (and remove any glue from open (unused) grooves) and let dry.

STEP 4. TOWER ASSEMBLY with FLOORS

Locate tower floors (D-51) and floor support molding (balsa strips E-3).

On the inside of all wall panels, measure up 9-1/4" from the bottom (grooved edge) and make pencil marks at this point.

Try for fit, the assembly of wall panels "B"; "C"; "D"; "E" & "G". Cornerpost grooves may need sanding to remove glue.

Try for fit, the tower floor (D-51) and mark where notching is required to fit around cornerposts. Notch out D-51 floors using file or razor knife.

Cut a piece of E-3 balsa strip to fit between cornerposts attached to wall "D". Glue this piece of E-3 in place below the pencil line on wall "D". (That is the top of the E-3 molding should be 9-1/4 in. up from the bottom of wall.)

Cut two pieces of E-3 molding five (5) inches long. Glue one onto each of walls "C" and "E" taking care to center the E-3 leaving equal amounts of siding showing on left and right ends. As before, top of E-3 should be 9-1/4 up from bottom of wall.

Apply a bead of glue to the open grooves of cornerposts attached to wall "D" and also to the left cornerpost of wall "G", and the right cornerpost of "B". Assemble walls B-C-D-E-G.

Apply glue to the edges of one D-51 floor and install on top of E-3 pieces on walls C-D-E. Square-up fit of walls to floor and secure with string or clamps. Let dry.

Measure up from the D-51 floor just installed and make pencil marks on walls in the tower area at a point $9\text{-}1/4"$ up from top of D-51 floor. Cut and install in place more pieces of E-3 molding below these new pencil lines. Install second D-51 floor on top of these E-3 moldings.

Apply bead of glue to open grooves in cornerposts attached to wall "F" and also apply a drop of glue to the bottom of these cornerposts. Install wall "F" on rear of tower. Note that the E-48 cornerposts sit on top of the rear E-46 cornerposts of walls "C" and "E". Make sure that assembly is square and level.

Wrap string around tower to secure wall "F" while glue dries.

STEP 5. FINAL ASSEMBLY OF WALL SECTIONS

Glue wall panels "A" and "H" in place as shown in drawing from Step 3. Make sure walls fit all the way into cornerpost grooves and the house is square.

Cut pieces of E-3 balsa molding as before and glue in place as before below pencil lines on walls "A" and "H". NOTE: the E-3 pieces do not have to be one continuous piece. Shorter pieces can be used to make up the lengths needed.

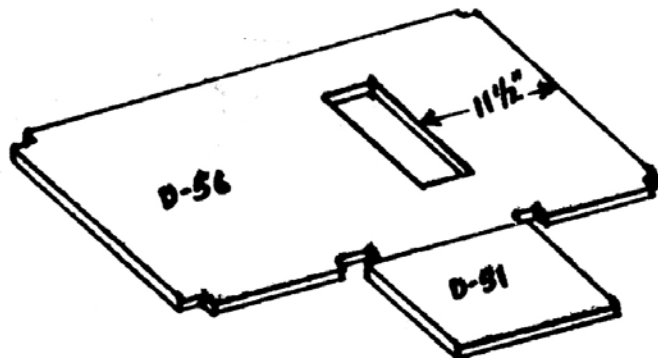

Locate second floor (D-56) and carefully press out hole for staircase opening. Sand opening to remove splinters. Check for fit of floor inside the house above the E-3 moldings installed. NOTE: placement of floor so that stair opening is $11\frac{1}{2}"$ from right side of house (facing from front). Notch D-56 as required for fit around cornerposts and for snug, level fit with tower floor D-51.

Apply bead of glue on top of E-3 moldings and install second floor. Make sure floor is level and house remains square. Tie string around entire house to clamp walls together and into floor. (NOTE: floor may appear to be undersized if walls are not fully inserted into cornerposts. Your floor can be adjusted for proper fit by sanding if too large or by covering gaps with E-3 molding if too small.)

STEP 6. INSTALLATION OF THIRD FLOOR

Locate third floor (D-57).

Measure up from second floor and mark 9-1/4" on all inside walls. Glue E-3 strips in place as before (Below the pencil line)

Try floor for fit and notch out to fit around cornerposts.

Glue in place as before. Tie with more string.

Locate rear floor trim moldings (E-52) and sand grooves to remove shavings. Try for fit across rear of house and trim if needed. Glue one molding to rear of each floor (D-56 and D-57).

STEP 7. TRIM CORNER POSTS

Do not be upset if you find that wall heights vary from wall to wall. Due in part to manufacturing tolerances in making the siding but more so because of varying amounts of glue used between the siding sections and different amounts of clamping pressure, walls will vary.

It is for this reason that corner posts are left slightly longer than needed. At this time, trim the cornerposts down using a small saw, razor knife, file or sanding block. Also, on walls "A" and "E" sand off the tongue from the top piece of siding.

STEP 8. ATTACH HOUSE TO BASE

Position the house onto the base from Step 1. Note that front of tower should be flush with front edge of C-3. Wall "A" should be flush with left side of C-2. Walls "B" and "G" should align with seam between C-2 and C-3. Wall "H" should align with seam between C-4 and C-2/C-3.

When proper alignment is achieved and all corners of the house are square, trace with a pencil the outline of the house (both inside and out). Remove the house from the base.

Apply white glue liberally within the penciled outline.

Re-position the house onto the base, lining it up with your pencil marks. Use weights to hold house in position.

While glue is tacky, cut and install pieces of E-3 molding (used here as baseboard molding) all around the perimeter of the house both inside and out. Set aside to dry thoroughly.

STEP 9. ROOF GABLES--Applying Shakes

While the work completed in Step 8 is drying, let us learn how to apply shingles by working on the roof gable triangles (D-5).

GENERAL HINTS ON SHINGLES AND THEIR APPLICATION

The shingles in this kit are made from solid wood veneers which are somewhat fragile and should be handled carefully. The veneer sheets have been partially die-cut into rectangles measuring 3/4 x 1-1/2 "

(Part G-1). DO NOT TEAR OR BREAK APART these shingles or they will split and many will be spoiled. Instead, re-cut along the die lines with a razor knife. Work slowly and carefully. Press a little harder when cutting across the grain. Fold the shingles back along the cut lines and they should separate easily.

Fancy or Plain? Whether you use plain, rectangular shingles, as provided or make your own fancy cut-corner or rounded shingles is a matter of personal taste and the time you wish to invest in shingling. A simple technique for making cut-corner shakes is described below:

Fancy shingles are made by cutting off two corners of a plain shingle using a sharp scissors or razor knife. Always cut from the outside edge into the center to avoid splitting.

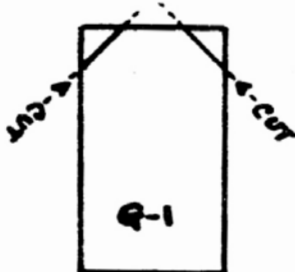

HINT: you may find it easier to bundle up 20 or 30 shingles into a neat and square bundle, secured tightly with masking tape. Take this bundle and cut the corners off with a razor knife; then sand to uniform size by rubbing the bundle of shakes on your sanding block. Remove the tape and you have made many fancy shakes at the same time.

Bundles of round cornered shakes (Fish scale shakes) can be made in this same manner.

Since most people prefer the Victorian look of fancy shakes but are reluctant to spend the time making them, a compromise is to use fancy shakes on the gable triangle and plain shakes on all roofs.

Applying Shakes A thicker, quick-tack wood glue such as Model Homes brand "Doll House Builder's Glue" is suitable for applying shakes. Because these water based glues may cause shingles to curl the shakes should be taped in place until glue sets.

The hot-melt glues, as dispensed by an electric glue gun, are ideal for applying shakes since adhesion is instant and curling is totally avoided.

When applying shingles, guide lines must be drawn on the surface to be shingled. The first line is drawn 1-1/2 in. up from the bottom. From this first line, measure up 1 inch and draw another line. Continue to draw lines, spaced 1 inch apart, all the way up to the peak of the roof.

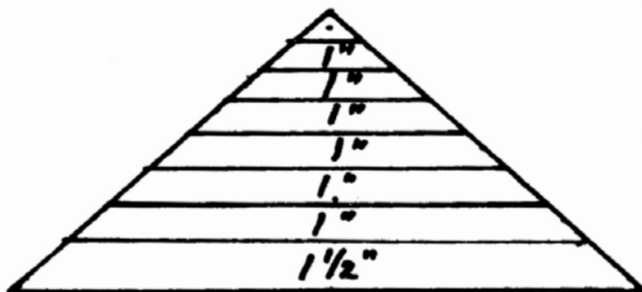

Draw these lines on both gable triangles (D-5) on the rough side, with your first line 1 1/2" up from the base (longest side) of the triangle. Additional lines are spaced 1" apart.

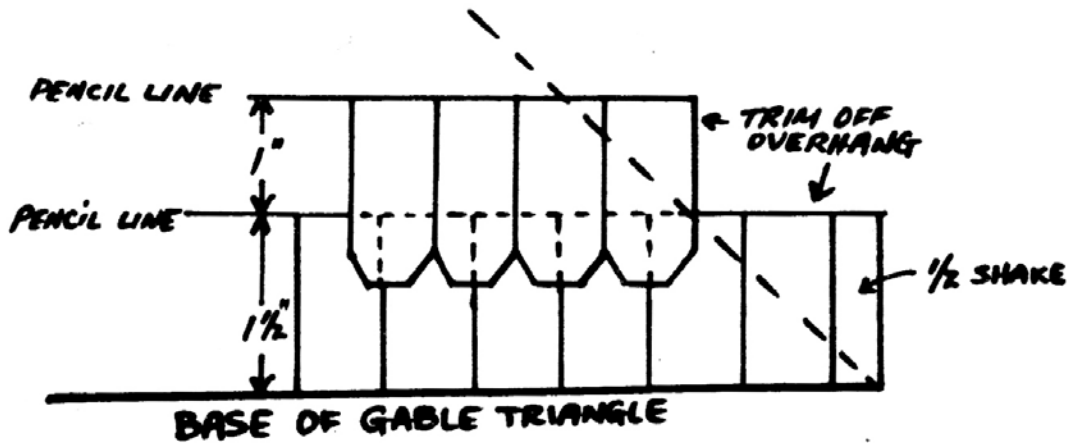

Starting with half a shingle (cut lengthwise), glue a row of plain shingles across the base of the triangle. Make sure shakes are flush with the bottom of the triangle; allow them to hang-over the other edges for trimming later.

Start applying fancy shakes (if you desire) on the second row. Note how each row of shakes overlaps the row below. Each shake is centered over the seam (joint) between two shakes below it in the next lower row.

Cover the entire gable in this manner.

After glue is thoroughly dry, trim overhanging shakes using a razor knife.

STEP 10. INSTALL GABLE TRIANGLES

Try the fit of gable triangles on top of walls "A" and "H". Center for equal overhand in both front and back. IMPORTANT: Make sure you have removed the tongue edge of siding as directed in Step 7 and that cornerposts have been trimmed if needed.

Apply liberal bead of glue to base of gable triangles and attach as above. Clamp with spring type clothes pins or spring clamps. Masking tape is also helpful to hold in place while glue dries.

STEP 11. WINDOW & DOOR TRIM INSTALLATION

Glue door side casing parts (B-4) onto siding of door opening in wall "A". Install so B-4 is flush with base; small gap between top of B-4 and B-2 siding spacer is not important.

Glue top door casings (B-5 from die-cut plywood sheets) in place, both inside and out. Square up door opening.

Repeat these steps for door openings in walls "H" and "G".

Install with glue, window side casings (B-3) to all windows. Make sure bottom of B-3 touches window spacers (B-1 & B-65) installed in Step 2.

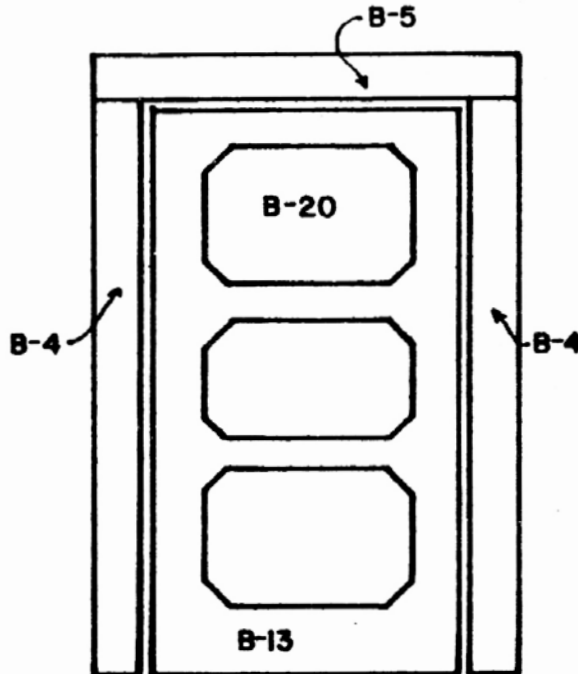

Glue top window spacer (B-1 for single windows and B-65 for double windows) in place so it rests on top of side casings B-3. Sand to fit if too thick; if gap appears above spacer between spacer and siding edge, it is not important.

Install bottom casings (B-5 or B-63 from die-cut sheets) both inside and out. Install this same part as a top casing on the inside only. Make sure window openings are square.

STEP 12. "FEDERAL" WINDOW ORNAMENTATION

Locate Parts: <u>Single Window</u>	Base: B-46
	Triangles: B-51
<u>Double Window</u>	Base: B-64
	Triangles: B-62

All of these parts are on die-cut plywood sheets.

Refer to the generalized drawing for "Federal" Windows for placement of parts. Base Parts are glued on top of B-3 casings to form a shelf. Glue three of the proper size triangles together to form one thick triangle. Sand this thick triangle until edges are flat and smooth. Cut E-3 balsa molding to fit on front of triangle and glue in place as shown. Glue completed triangle on top of base, centered and flush with the back edge of the base. Glue B-33 pine decor blocks under base, attached to B-3 casings. Note position of $3/4$ " edge of B-33 block in detail drawing.

Proceed to attach these parts to the proper windows.

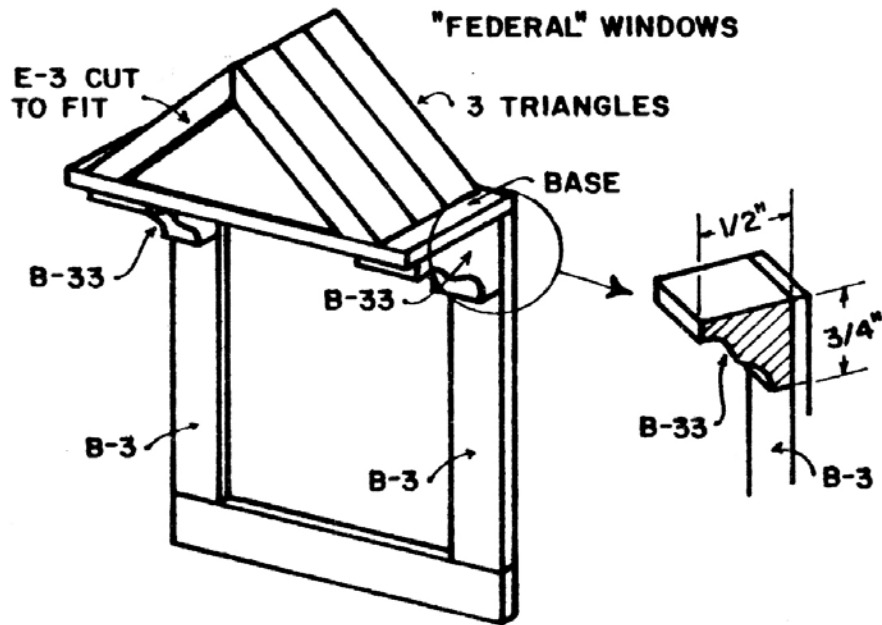

STEP 13. MAIN ROOF ASSEMBLY

Attach front roof panel (D-55) to ridge cap (E-14) using glue. Note that rough side of D-55 faces out and dormer window cutout is on right. Clamp in place with spring clamps.

Attach rear roof parts (D-8) in the same manner (Rough side up).

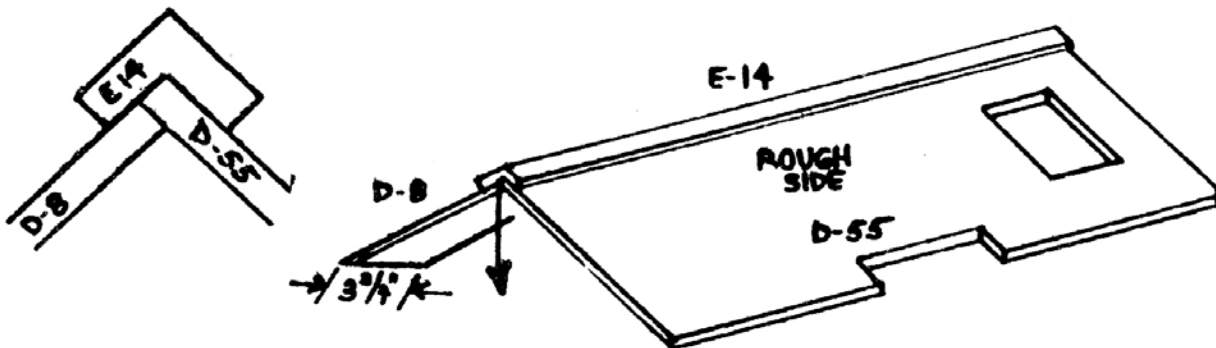

STEP 14. ATTACHING ROOF

Try (without glue) the fit of the main roof assembly to the gables. Some trimming may be required for fit around tower on right side. Roof should overhang equally on both right and left sides of house. Any gaps between roof and tower will be covered by shingles.

Apply thickened glue to all contact points and install roofs in place. Hold tightly with tape or weights. Let dry.

Locate eaves moldings (E-51 and E-53) and try for fit under front roof overhang. Note that the 3/4 edge of the molding is glued to the siding of house and the 1/2" edge faces up. Some minor trimming may be needed for proper fit over cornerposts. E-51 is installed to the left of the front tower and E-53 to the right.

STEP 15.**DORMER CONSTRUCTION**

Carefully press out all dormer parts from die-cut sheets (Parts K-1; K-2; K-3). Clean out slots and sand edges smooth.

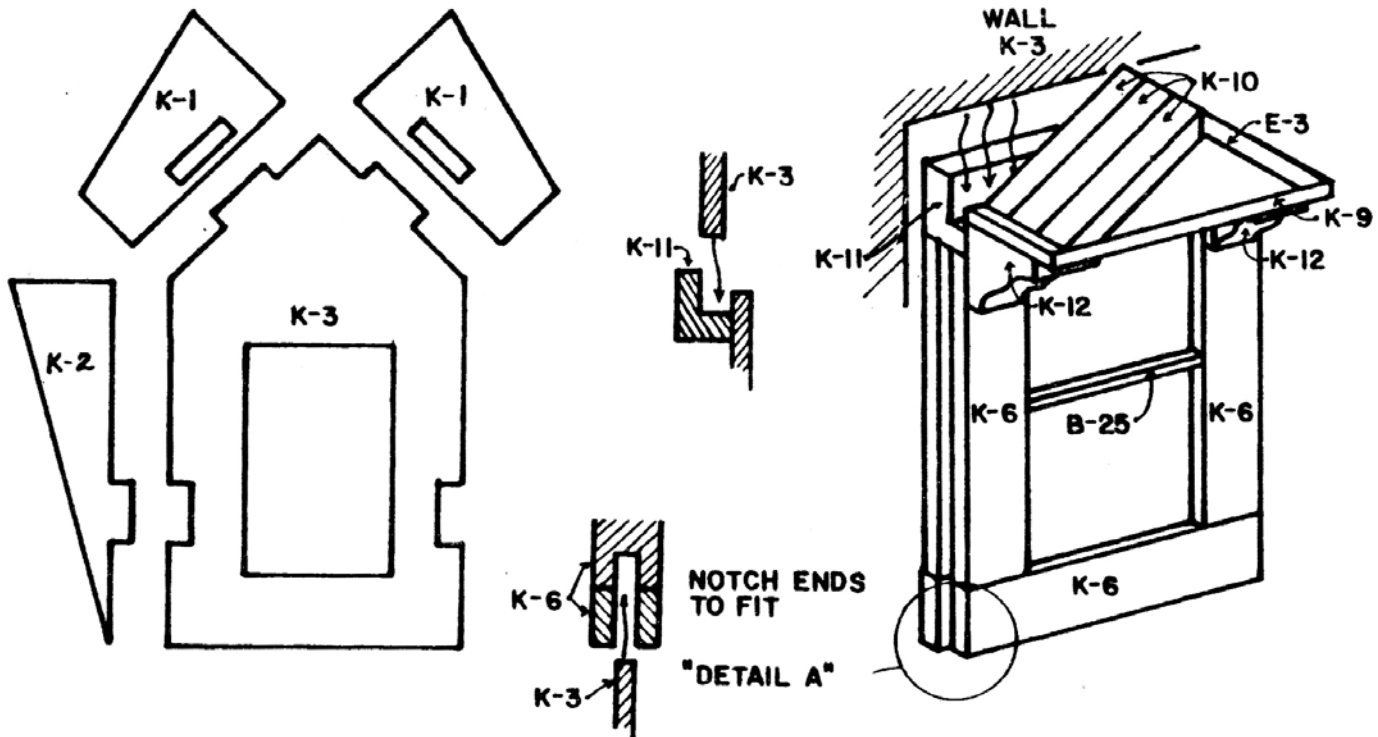

Locate Parts K-6 and K-11. Sand the grooves in K-6 so they fit freely onto window hole sides in K-3. You may also wish to sand or file the edges of the opening in K-3 on a slight bevel to facilitate the fit of K-6.

As illustrated in drawing detail, cut a notch into both ends of one K-6 and the K-11 part, using razor knife, small saw or file. Be careful to avoid splitting the parts. If however, the part does split, merely glue it back together.

Install the one notched K-6 part onto the bottom of the window opening as shown. Glue the two plain (un-notched) K-6 parts on the left and right sides.

Glue K-11 part in place as shown from the inside of the dormer. Square-up window opening.

Glue K-2 Dormer Sides in place by aligning notches to tabs. Let dry.

Position assembled dormer on roof over dormer hole cut-out. Center dormer over hole and mark position with pencil outline. Apply liberal coat of glue onto pencil outline on roof and press dormer in place. Clamp with masking tape and let dry.

Locate Dormer Roofs (K-1) and glue in place as shown. Tab in K-3 should snap into slot in K-1.

Locate the three die-cut triangles (K-10) and press out from plywood sheet. Sand edges. Glue these K-10 triangles together to make one thick triangle. When dry, sand edges flat and smooth.

Locate K-9 part and two K-12 blocks. Glue K-9 in place with the K-12 blocks positioned beneath to form a shelf, as in Step 12. Glue thick K-10 triangle on top of K-9. Cut two pieces of E-3 balsa molding as shown and glue onto the front of K-10.

Cut piece of B-25 balsa molding to fit between K-6 window sides making a window divider. A single piece per window will simulate a Victorian double-hung window.

Also, cut E-3 balsa strips to cover front edges of K-3 where tab from K-2 is visible.

At this point, before roofs are shingled, it may be easier to paint the dormer. Usually dormers are painted in the same color as the siding of the main house walls. The dormer roofs will be shingled later, when main roof is shingled.

STEP 16 SIDE SERVICE PORCH

Locate porch railings (H-13 and H-38). Make pencil marks on these parts to locate position of railing posts (H-7), as shown in drawing. Construct one railing section by gluing a post (H-7, the longer $2\frac{1}{2}$ " dowels) between upper and lower railing channels (H-13), taking care to position dowels H-7 so that they line up evenly with pencil lines on top and bottom rails. In same manner, construct two identical sections using H-38 railings. Keep railing sections squared-up and set aside to dry.

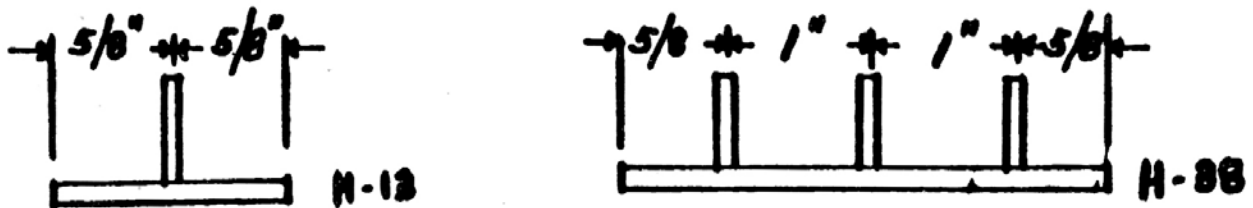

Locate remaining parts as shown in drawing: H-3; H-29; H-26; H-10. Practice placement of these parts without glue.

If railing sections from above are completely dry, sand a round-over on the top railing of each section

Working on a flat, waxed paper covered surface, construct the "H" shaped assembly formed by gluing one H-3 post and one H-12 post connected by the H-13 railing section. Note that railing section is $1/4$ " up from bottom of posts. Glue H-16 post top on top of H-12. Square up this assembly and let dry.

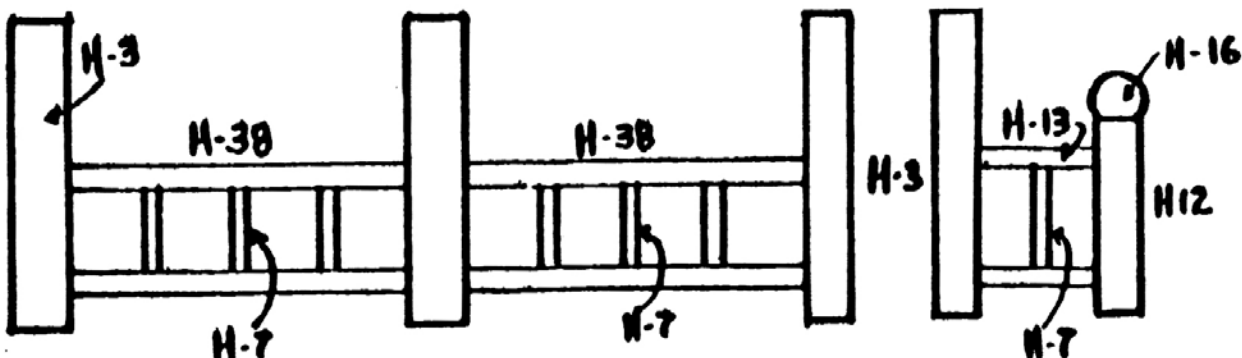

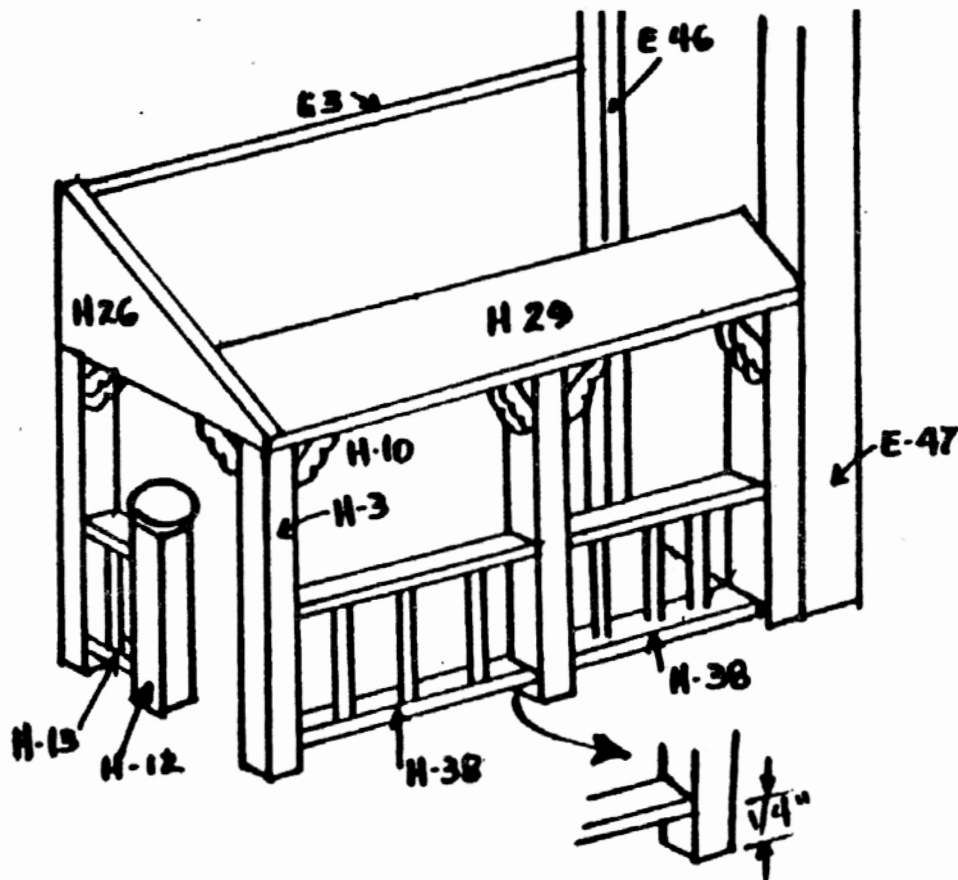

In this same manner, construct the assembly shown using three H-3 posts and the two H-38 railing sections made above. Square-up and let dry.

Study the dimensional drawing of the side porch for the proper placement of these railing/post assemblies just made. Apply drop of glue to the bottom of each post on the three post assembly. Also apply a narrow bead of glue to the right post edge. Install this assembly as shown, with the right H-3 post glued to the front left E-47 tower cornerpost. Assembly should line up with front edge of base.

Test the fit of H-29 on top of H-3 posts; it may be necessary to trim the length to allow H-26 triangle to sit on top of left H-3 post. Or, if too short, leave a gap between H-29 and E-47 (porch roof will hide gap). After making size adjustments, glue H-29 in place.

Glue the remaining railing section in place by applying drop of glue to bottom of H-3 and H-12 posts and to back edge of H-3. Glue in place so porch is square.

Glue H-26 triangle in place and clamp with tape.

Glue H-10 trim pieces in place as shown.

Cut a piece of E-3 balsa molding to fit between H-26 and E-46 cornerpost. This will serve as a support for porch roof. Glue in place and hold with tape.

Try fit of porch roof (D-45). Notch out to fit around cornerposts, making sure rough side of roof faces up. Glue D-45 in place. Tape or weight until glue dries.

STEP 17.

PORCH STEPS & RAILINGS

Locate Step Railing parts (H-6) and sand round-over on top edges to match porch railing tops.

Glue together front step base (H-8) and upper step (H-9) and then glue this assembly in place

Sand or file an angle on one end of both H-6 railings to blend into porch post. Glue railings and posts in place as shown.

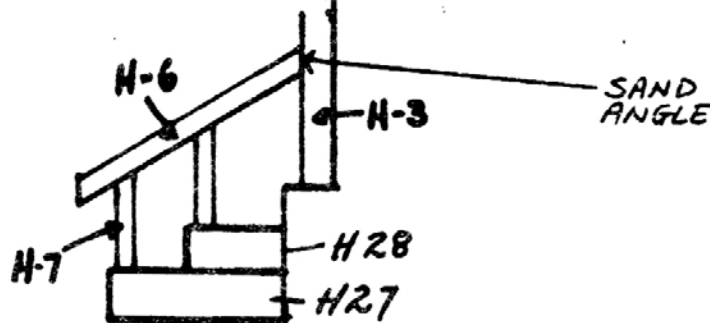

STEP 18.

SHUTTERS & DOOR

Press out shutters (B-6) and sand edges. Do the same for shutter trim diamonds (B-50). Glue diamonds in place as shown. Use same spacing for all shutters so they will match. Set aside to dry.

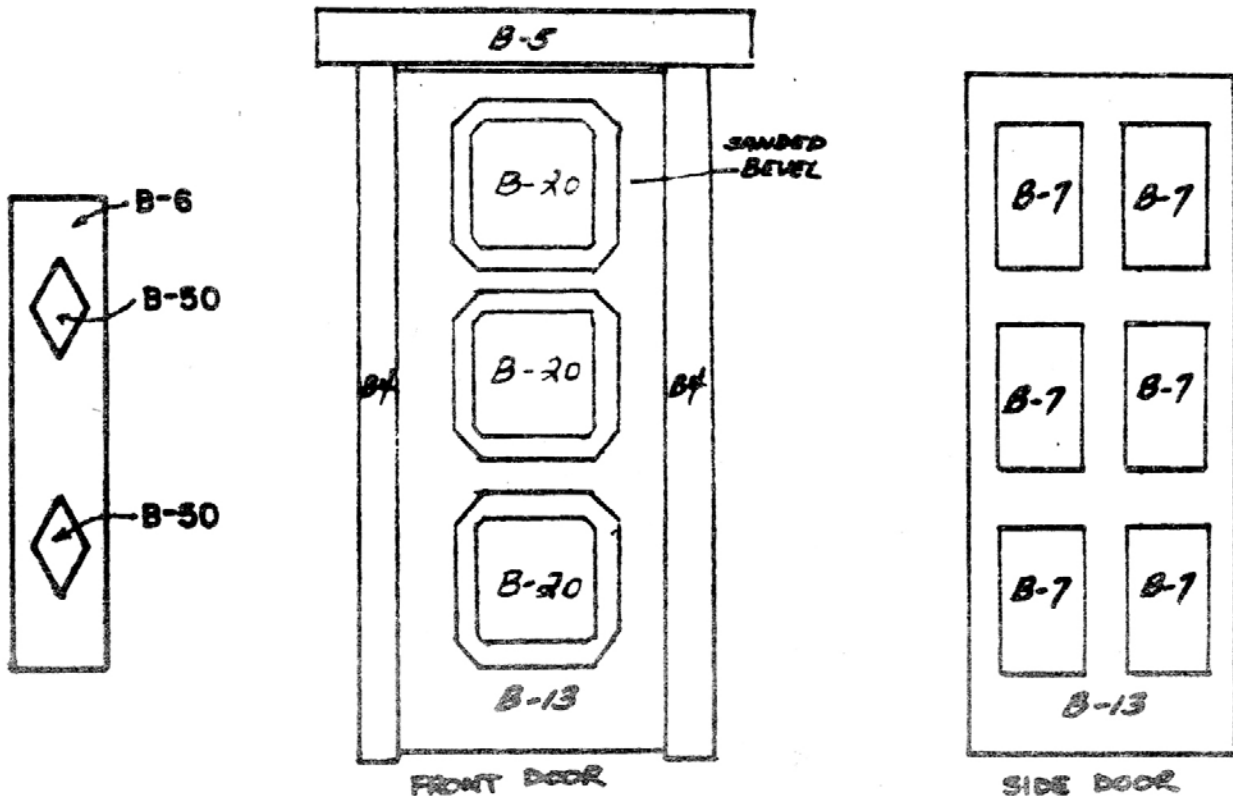

Do not attach shutters to house at this time since it is easier to paint them first.

Locate door (B-13) and door decor parts (B-20) as shown. If kit is furnished with thin door (1/8 to 3/16 thick), cut a piece of G-2 balsa molding to 7-3/8" long. Glue this G-2 strip in place on the inside surface of the door on the side to which hinges are to be attached. This will provide additional thickness for hinge hardware, if used (hinges are available as accessory item and are not included in kit).

Sand a slight bevel on edges of door decor parts (B-20) and glue onto door.

When dry, try door for fit within door opening in wall "G" (Front Door). Some size adjustment may be required for smooth door operation and proper clearance.

Door may be installed with a tape hinge or use pieces of fabric tape (such as surgical tape) applied between inside of door and door casing. Miniature butt hinges, door knobs and door knockers are readily available from your dealer or by mail, if desired.

For side service porch door and balcony door, attach B-7 trim pieces as shown. Installation procedure is the same as for front door.

STEP 19.

STAIR & RAILING CONSTRUCTION

Study the drawing and locate all parts.

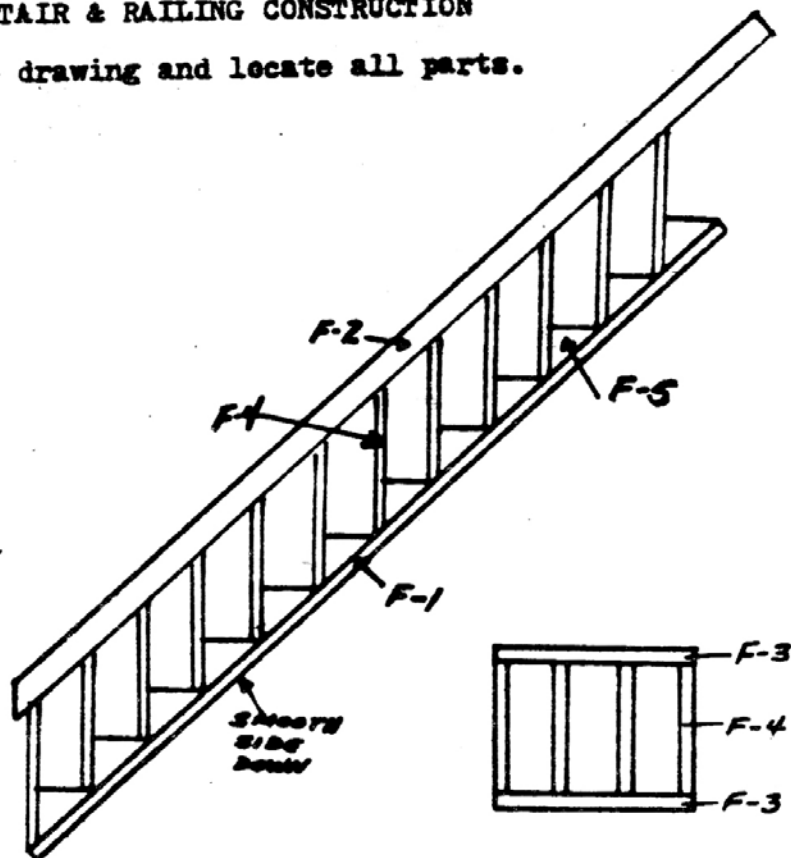

Apply glue to the longest side (approx. 1" side) of stair treads (F-5) and glue in place on hardboard base (F-1) on rough side. Space steps evenly to cover entire base. Apply weights to minimize warpage and set aside to dry.

Assemble a three inch railing section (F-3 railings and F-4 posts) as shown. Square-up and let dry.

Glue bannister posts (F-4) in place against back of stair steps, as shown.

Posts are glued on the right side of steps, about 1/8" in from edge. Let dry.

Sand round-over on top edges of handrail (F-2).

If bannister posts are dry, carefully glue handrail (F-2) so that it is flush with post on bottom step and overhangs above top step.

Apply weights to finished assembly and allow for thorough drying.

STEP 20 INSTALL STAIRS AND PARTITION WALLS

Locate divider wall D-31 and measure to locate 9 1/4" edge. Glue in place between base and second floor on the left side of stair opening in second floor. Make sure wall is vertical (plumb) and rear edge touches E-52 rear floor trim. (Left side when viewed from front of house).

Glue second D-31 between second and third floors, positioned directly above the first D-31 wall. Again, check for squareness and make sure plumb.

Install smaller D-52 partition between second and third floors on the right side of stair opening. At the same time, glue the 3" railing section in place at the front of stair opening between D-31 and D-52.

Position stairs in stair opening so that staircase starts in front of house on first floor and ends up in rear of house on second floor. Handrail should be on the right, when viewed from front of house. Glue in place.

Locate Attic dividers D-63 and glue in place to divide attic space to suit your taste or needs for furniture placement. This partition may require trimming to fit snugly. Apply E-3 molding to dress up base or edges of all partition walls.

STEP 21. PORCH RAILING CONSTRUCTION

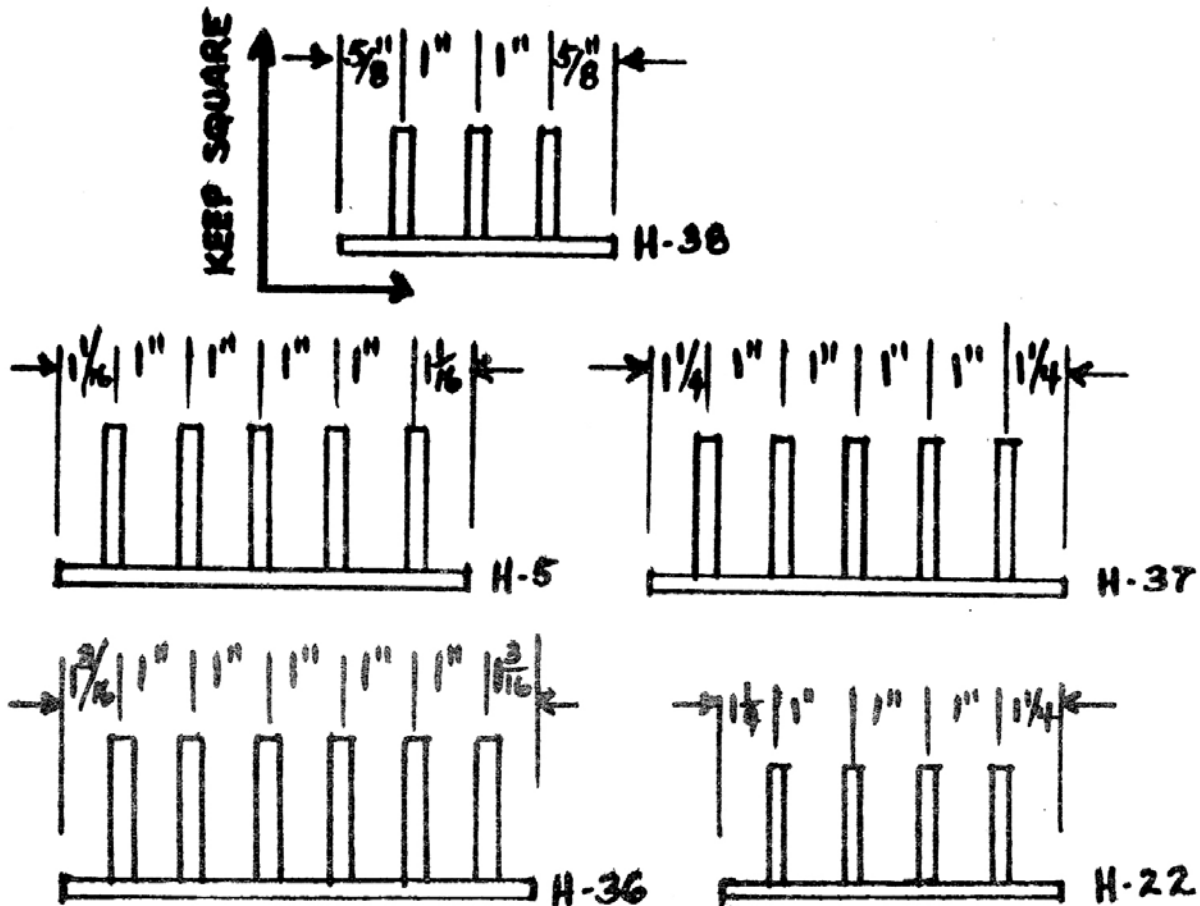

Railing sections for the main lower porch and balcony are constructed in the same manner as in Step 16. Sort and identify all railing parts as shown. Note the number of dowel posts (H-7) used in each section. Make pencil marks on these parts as shown in drawing to locate position of railing posts.

In all cases, position dowels (railing posts) so that they line up evenly with pencil lines on top and bottom railings. Keep all sections square and level. Set aside to dry.

STEP 22. MAIN PORCH ASSEMBLY--Sub-Assemblies

Locate all parts as shown in drawing and arrange them as indicated. Work without glue on a flat surface.

Check that your railing assemblies from Step 21 have dried true and square. Note that railing sections are elevated $1/4"$ up from base. Note too the placement of the mitre-cut (pointed) end of Support Moldings E-55 & E-54.

Size adjustments may be required on length of E-55. Line up pointed end of E-55 with far right post (H-35) and if the left end of E-55 extends beyond the total length of the porch assembly, trim E-55 down to size. If undersized, shorten length of H-37 railing assemblies. The same applies to E-54.

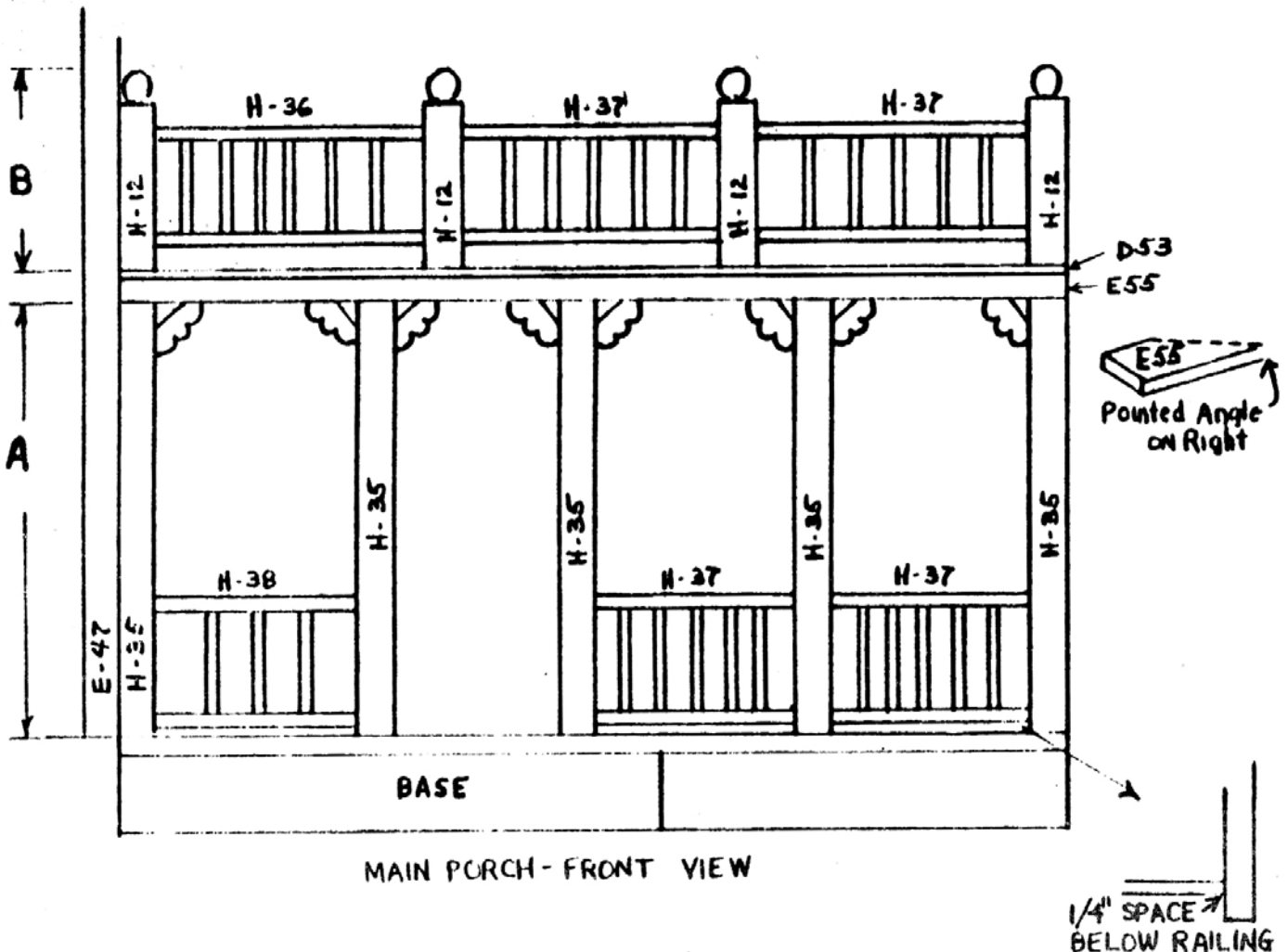

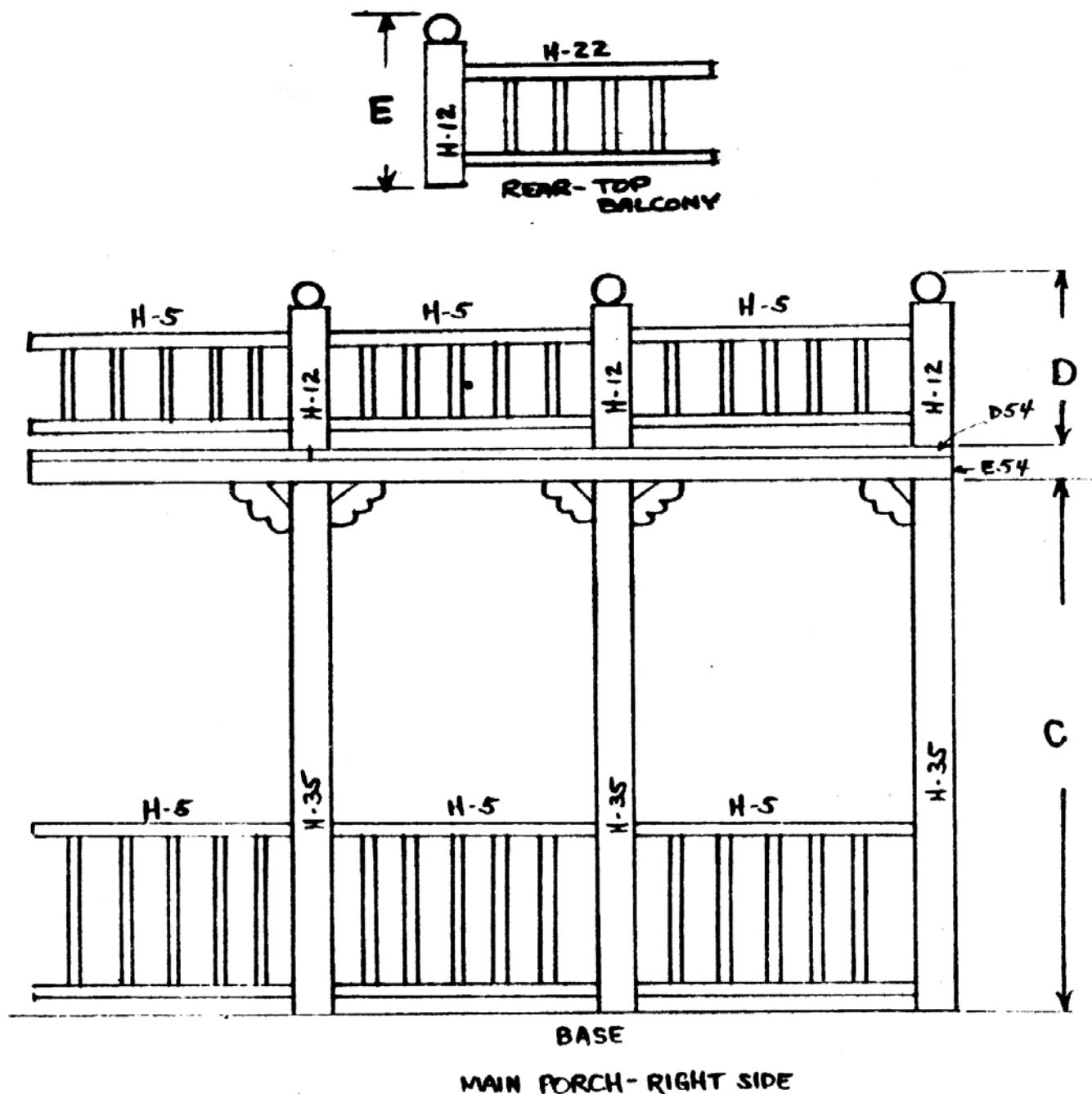

Proceed to glue together these parts after making the required size adjustments. Work on a flat surface covered with waxed paper. Assemble five separate sub-assemblies:

- A. Main Porch--lower front section
- B. Front balcony
- C. Main Porch--lower right side portion
- D. Side Balcony
- E. Rear Balcony

Make sure that your work ends-up square and that the bottom of all posts are level!

Let these assemblies dry completely.

STEP 23. MAIN PORCH & BALCONY--Installation

If the sub-assemblies from Step 22 are dry, proceed to glue them in place onto the base, right of the front tower, as follows:

Align sub-assembly "A" (main porch--lower front section) with front wing cornerpost (E-47). Make sure that this sub-assembly is positioned parallel to the house (wall "G") and glue in place.

Position sub-assembly "C" (Main Porch--lower right side portion) so that the angle cut on E-54 mates up with E-55. This sub-assembly should square-up with sub-assembly "A" and follow right side of house. After adjusting for fit, glue in place.

Try for fit the hardboard balcony floor (D-53) on top of E-55. Notch to fit around cornerposts, making sure smooth side is up. Glue in place. (You may wish to glue strips of E-3 balsa molding under rear of D-53 for extra support)

Likewise, glue D-54 in place on top of E-54 after notching for fit. (NOTE: smooth side up!).

Next, glue sub-assembly "B" (Front balcony) in place on top of hardboard as shown. Mate "B" up with "D" (side balcony) and glue "D" in place after making necessary adjustments.

Finally, Glue sub-assembly "E" (Rear balcony) between "D" and the rear cornerpost of house (E-45).

Cut pieces of E-3 balsa molding to fit between hardboard and house walls as a baseboard molding to cover any gaps or irregularities of fit. Glue E-3 in place.

STEP 24. PORCH STEPS & RAILINGS

Study the drawing showing a side view of porch steps. Locate all parts shown.

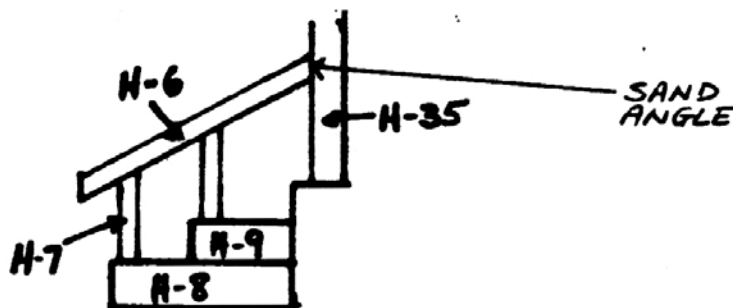

Sand a round-over on top edges of step railings (H-6).

Glue together front step base (H-8) and upper step (H-9) and then glue this assembly in place.

Sand or file an angle on one end of both H-6 railings to blend into porch posts. Glue railings and H-7 dowels in place as shown.

STEP 25. CHIMNEY

Glue together two chimney blocks (J-13) and glue on the cap part (J-12), centered on top as shown.

After glue is dry, sand the edges and flat surfaces of the chimney. Paint the chimney or extra realism, apply Model Homes brick and mortar, available at your local dealer or by mail.

Glue chimney onto roof. Position on left front side of roof, about $1\frac{1}{2}$ " in from roof edge.

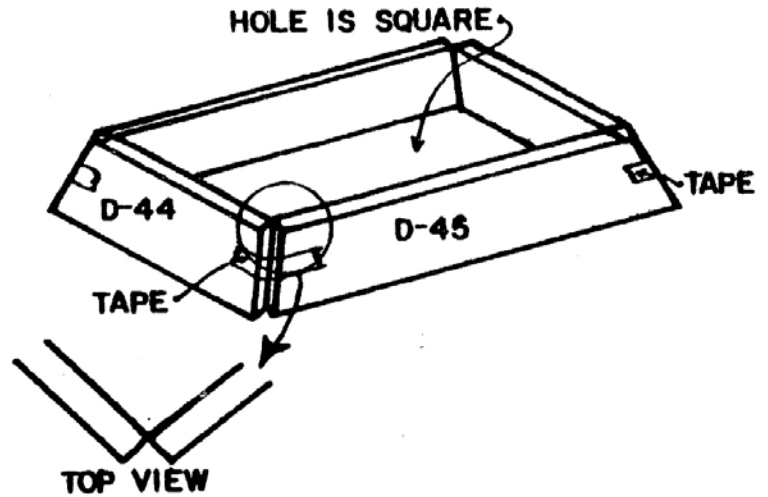
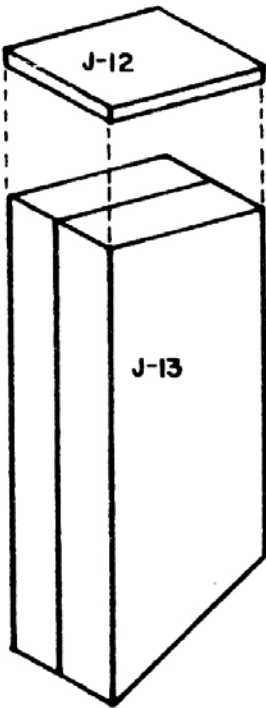

STEP 26. WIDOW'S WALK

Press out widow's walk roofs (D-44 & D-45) from die-cut sheet. Arrange as shown in drawing and practice assembly so that top opening of roof assembly is square. Note in detail drawing that there will be an angular gap in the corners since the roof parts only touch inside. When satisfied with the assembly, glue it together and fasten with tape. Let dry.

Sand a round-over on top edges of two of each railing section (H-31 & H-32). Make pencil marks on all pieces of H-31 and H-32 as shown.

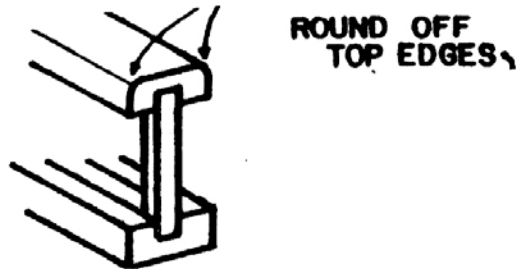

Using the procedure from Step 16, construct 4 railing sections: two sections of H-32 and two of H-31. This time use the shorter dowels (H-33) Square-up and let dry.

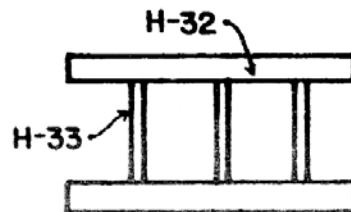
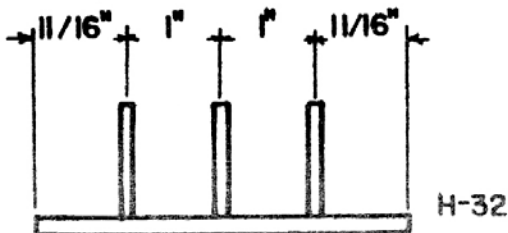

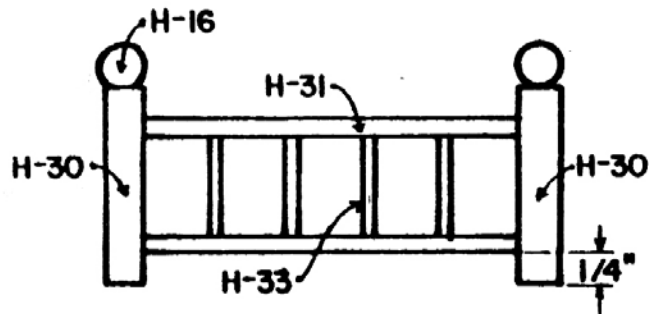

Working on a flat surface, assemble an H-31 railing section to H-30 posts as shown. Again, railing should be 1/4" up from bottom of posts. Let dry.

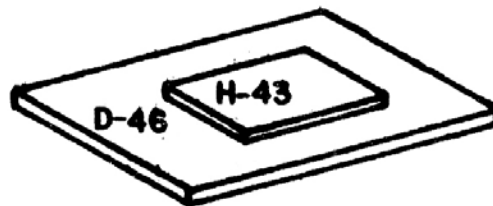

Locate hatch cover H-43 (this is the punch out from K-3 dormer front). Glue in place on D-46, centered on top.

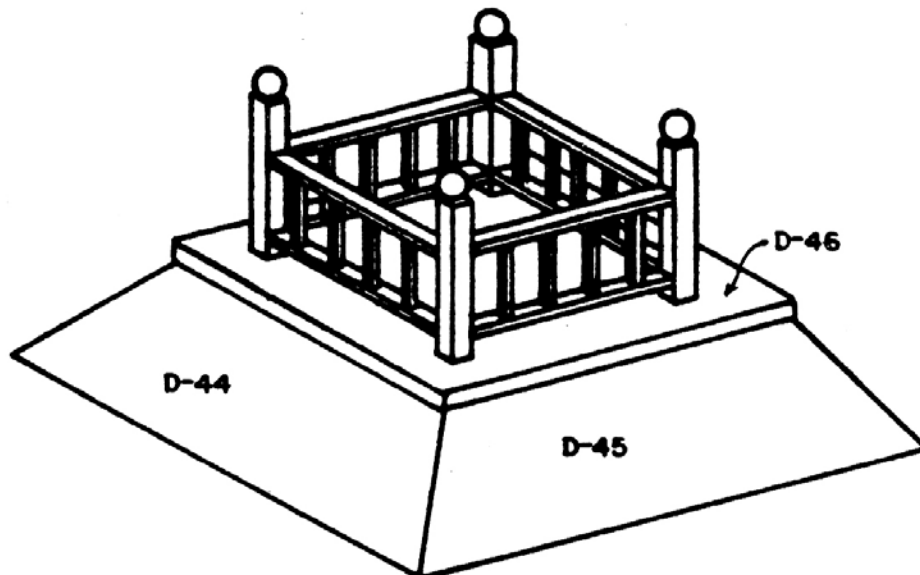

Glue all railing sections and posts on top (smooth side) of D-46 widow's walk base. Assembly should be square and centered on D-46. Glue a post top button (H-16) on top of each H-30 post. Let dry.

Apply liberal amount of glue to top edges of roof assembly from above (D-44 & D-45 assembly) and attach D-46 assembly on top. Again, center all parts. Apply weights and let dry.

NOTE: This entire widow's walk assembly will ultimately sit on top of the tower section of house. It should NOT be glued there since it will serve as a "lid" providing access to the tower room.

STEP 27. ROOF SHAKES

Re-read Step 9 on General Hints for Shingles. Follow these instructions to apply shakes to all roof surfaces, including dormer roof and widow's walk roofs.

STEP 28. FINISHING TOUCHES

Window Dividers Use the balsa moldings (E-3 and B-25) to make dividers for all single windows. A single piece will create the look of double-hung windows, so typical of Victorian houses.

For the two double windows, glue divider part (B-29) in the center of window opening. Add balsa parts for dividers.

Shake Moldings Attach G-2 balsa moldings to edges of main and rear roofs, along gable triangles.

Trim Moldings Use molding (either balsa strips or strips cut from scrap plywood left over from die-cuts) wherever gaps or unsightly joints occur. Depending on your neatness in shingling, the dormer roof peak may need some molding to dress it up a bit. Scrap shingle veneers also make excellent moldings; cut to size as needed.

PAINTING TIPS It is suggested that you seal the entire house both inside and out with shellac or suitable primer. It is especially important that the inside walls be sealed before wallpapering.

Use a compatible top coat of paint over the prime coat. Model Homes brand of Doll House Paint is a high quality, water based paint in convenient 8 oz. jars. Ask for it at your dealer! Any latex primer or shellac would be compatible with Model Homes paints.

Shakes may be left unpainted (natural) or stained with wood stain. Staining will eliminate any variances in color of the veneers supplied (even very light and dark veneers will match if stained with proper wood stains.) Experiment with scrap shingles before staining entire roof.

STEP 29. "TAKE A BOW"





Congratulations! Your miniature house is now completed. Take a minute to step back and admire your own work. Now record this historic moment by completing the Official Doll House DEED--a record of your accomplishment.



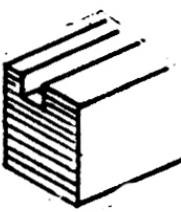
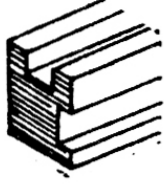

MISSING OR DEFECTIVE PARTS?

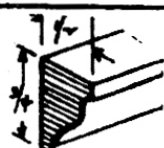

Every effort has been made in the manufacture and packing of this kit to insure an adequate supply of parts. Your kit has been inspected at various stages by our quality control personnel, whose employee codes are punched on the enclosed Inspection Sheet/ Order Form.

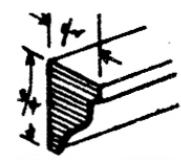
If however, a part has been omitted; or broken in shipment; or is defective, it is important that you USE THE FORM to order replacement parts directly from us. Parts orders will be shipped via parcel post at no charge. Follow the instructions for ordering as printed on the form. Make sure you include the model number of this kit and the part number(s) involved.

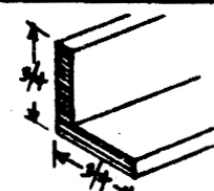
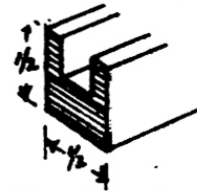
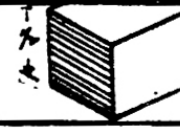
Various extra parts for customizing your doll house are also listed on the form. These parts may be purchased at your local store or ordered by mail.

Part No.	SIDING (Bundles & Bags)	Qty
A-34	 16-1/16	4
A-35	13-13/16	16
A-27	7-7/16	6
A-37	8-1/8	10
A-28	6-7/16	13
A-29	5-5/16	32
A-38	4-15/16	5
A-4	3	9
A-39	2-11/16	5
A-8	2-1/2	6
A-30	1-7/8	18
A-31	1-1/2	12
A-33	1-1/8	10
E-45	BUNDLE: Cornerposts & Trim Molding  19"	2
E-46	 19"	6 7
E-54	 20 1/2	1
E-55	22 1/2	1
E-53	 16	1
E-48	BUNDLE: Cornerposts & Trim Molding  8-1/8	2

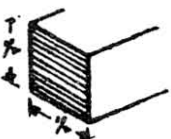
Part No.		Qty
E-51	 8-1/16	1
E-47	BUNDLE: Vy Long Moldings  27 1/2	2
E-14	 35"	1
E-52	 31"	2
BAG: Main Porch/Balcony-"A"		
H-8	Pine Block: 3/4 x 2 1/2 x 4-3/4	1
H-9	Pine Block: 3/4 x 1 1/2 x 4-3/4	1
H-35	 9"	8
H-36	7-3/8	2
H-37	6 1/2	8
H-5	6-1/8	12
BAG: Main Porch/Balcony-"B"		
H-7	3/16 Dowels--2 1/2"	67
H-16	1/2" wood buttons	8
H-12	 3"	8
H-22	5 1/2	2
H-6	3 1/2	2
H-38	3 1/2	2



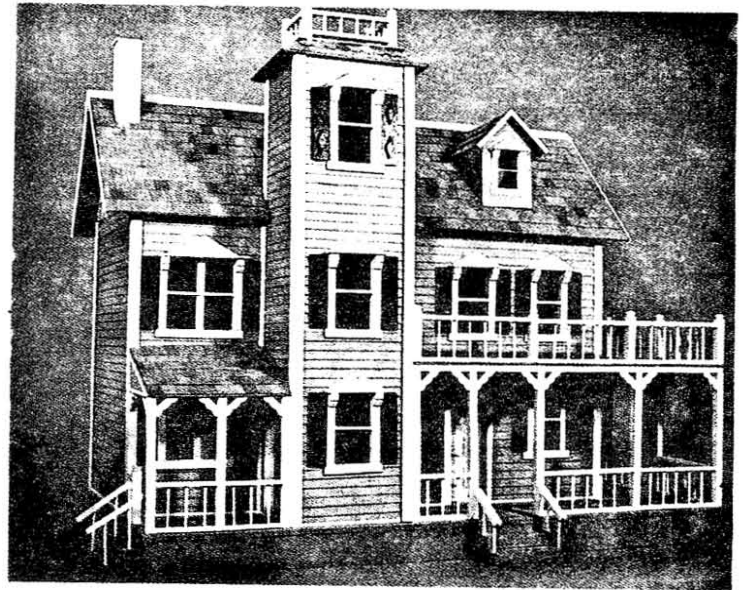

<u>BAG: Service Porch</u>			
H-27	Pine Block: $3/4 \times 2\frac{1}{2} \times 4$	1	
H-28	Pine Block: $3/4 \times 1\frac{1}{2} \times 4$	1	
H-7	$3/16$ dowels-- $2\frac{1}{2}$ "	11	
H-16	$\frac{1}{2}$ " wood buttons	4	
H-29	 $7-3/4$ "	1	
H-3		$7\frac{1}{2}$ "	4
H-12		3 "	1
H-13		$1\frac{1}{2}$ "	2
H-38		$3\frac{1}{2}$ "	4
H-6		$3\frac{1}{2}$ "	2

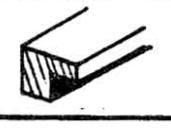

No. 1009 Victorian

Inspired by historic Cape May, NJ, an authentic Victorian with open porches and balconies for ocean viewing. Three story tower with widow's walk and "Federal period" windows. Seven rooms including a "secret" tower room (layout similar to No. 1202 on page 4).

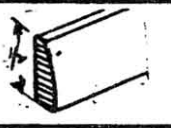
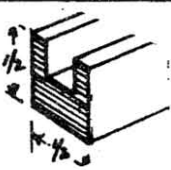
Overall Size: 19" x 43" x 35" Ship Wt. 40 lbs.

<u>BAG: Dormer & Chimney</u>			
K-6	 $2\frac{1}{2}$ "	3	
K-11	 $2\frac{1}{2}$ "	1	
K-12	 $\frac{1}{2}$ "	2	
J-13	Pine Block: $3/4 \times 1\frac{1}{2} \times 5\frac{1}{2}$	2	
<u>BAG: Window & Door</u>			
B-1		$2-5/8$	14
B-65		$4-3/8$	4
B-2	 3 "	3	
B-3		$4\frac{1}{2}$ "	18
B-4		$7\frac{1}{2}$ "	6
B-33	 $1/2$ "	28	
B-13	$\frac{1}{2}$ plywd door $2\frac{1}{2} \times 7-7/16$ "	3	

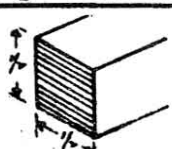
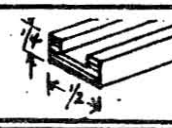
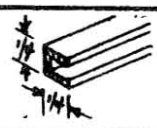
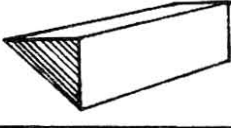
<u>BAG: Widow's Walk</u>			
H-33	$3/16$ dowels-- $1-1/4$	16	
H-16	$\frac{1}{2}$ " wood buttons	4	
H-30	 2 "	4	
H-31		$4-13/16$	4
H-32		$3-3/8$	4
<u>BAG: Stairs</u>			
F-1	$3 \times 12-7/8$ hardboard	1	
F-4	$1/8$ dowels-- 2 " long	16	
F-2		13 "	1
F-3		3 "	2
F-5	 3 "	12	
<u>PANELS: 3/8 Fibreboard</u>			
C-2	$14\frac{1}{2} \times 31\frac{1}{2}$	1	
C-3	$6\frac{1}{2} \times 31\frac{1}{2}$	1	
C-4	$6\frac{1}{2} \times 21$	1	
C-5	$1-7/8 \times 19$	4	
C-6	$1-7/8 \times 20\frac{1}{2}$	3	

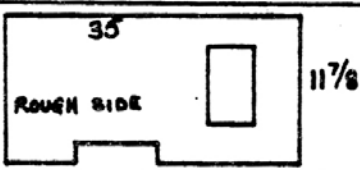
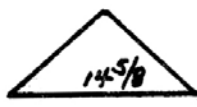
Part No.	PANELS: 1/8 Hardboard	Qty
D-8	3-3/4x11-7/8	2
D-46	4-7/8x6-1/2	1
D-53	6x22-9/16	1
D-54	6x14 1/2	1
D-55		1
D-45A	6 5/8 x 8 1/16	1
D-5	PANELS: 1/4 Hardboard 	2

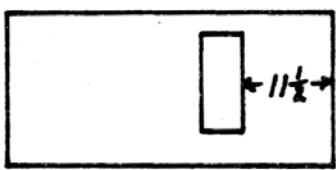
Part No.	PANELS: 3/16 Plywood	Qty
D-51	5-13/16x6-5/8	2
D-31	9x9 1/4	2
D-52	6x9 1/4	1
D-57	13-7/8x31 1/4	1
D-56		1
G-1	SHINGLE SHEETS 3/4x1 1/2 Shingles	
	DIE-CUT PLYWOOD	
I	Window trim	3
V	Shutters	2
VI	Widow's walk & trim	1
VII	Window & Porch	1
VIII	Misc. Addl parts	2
XII	Misc. Parts	1
XVI	Dormer	1

BALSA SHEETS

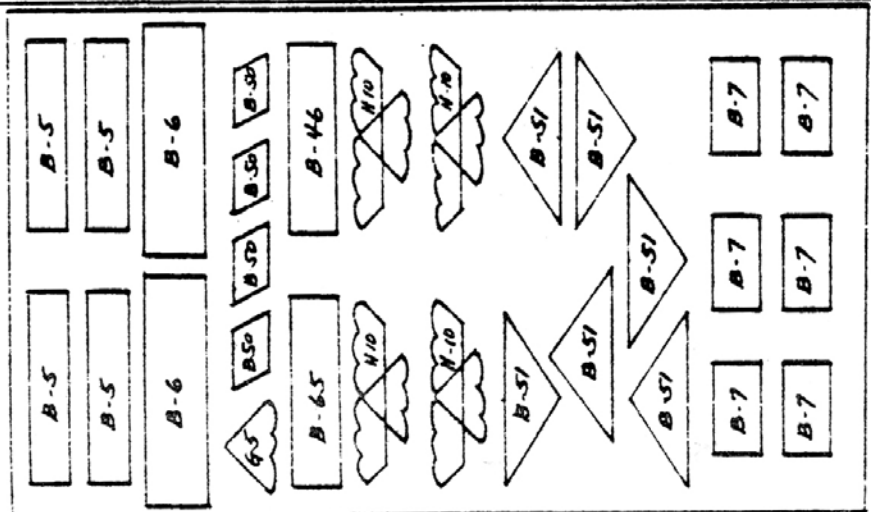
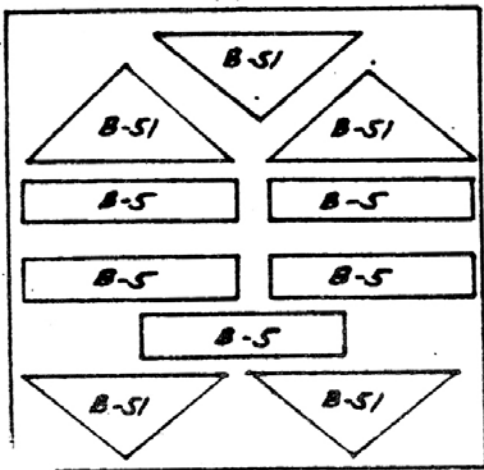
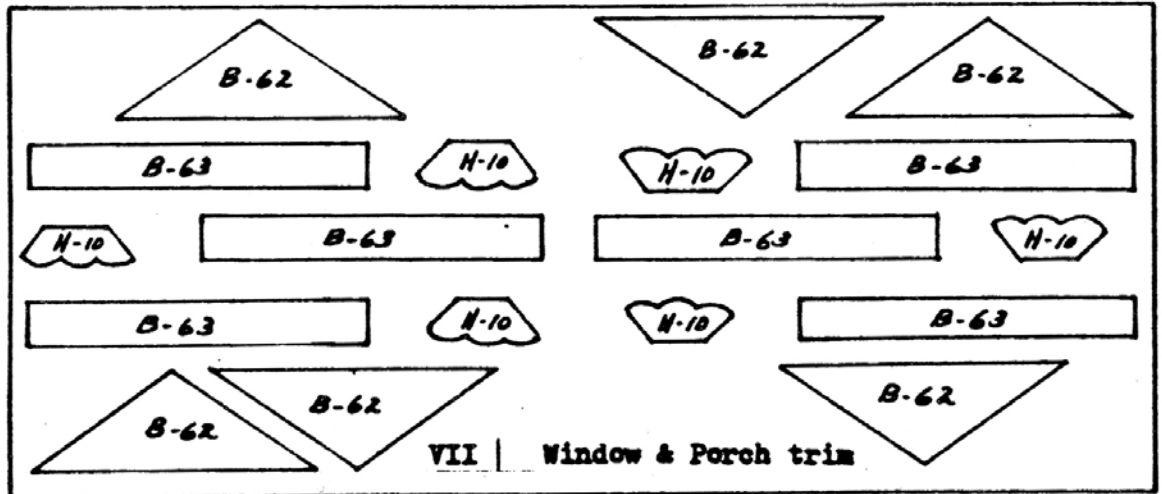

VIII | Misc. Addl parts

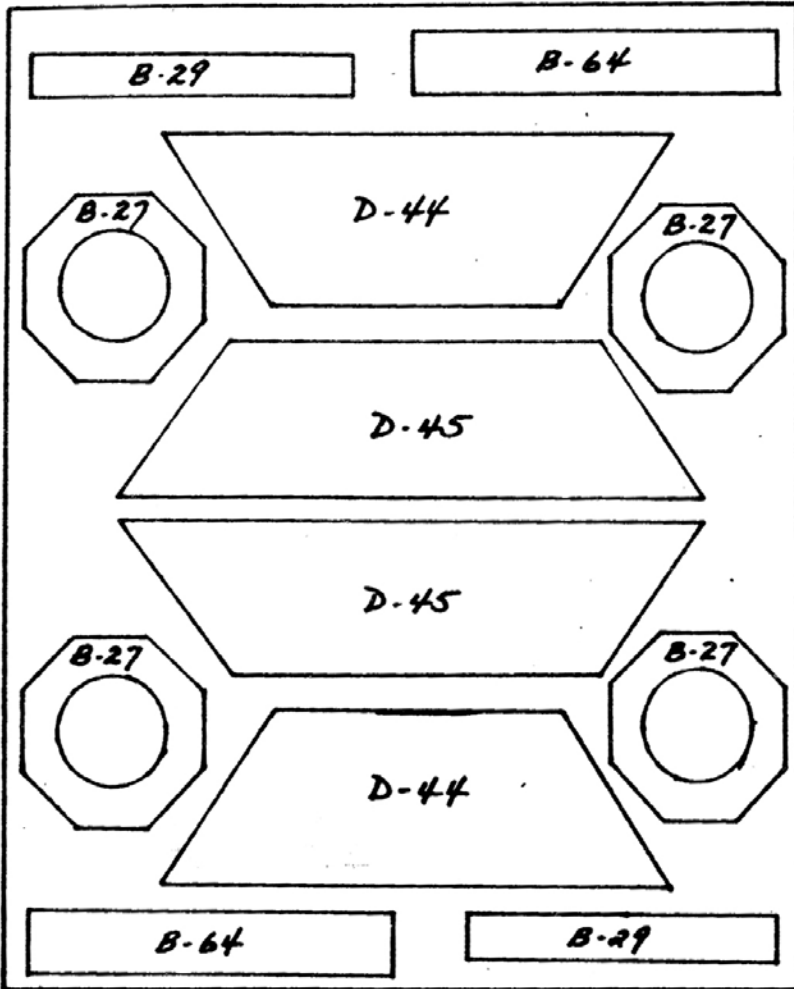

VI | Widow's Walk & trim

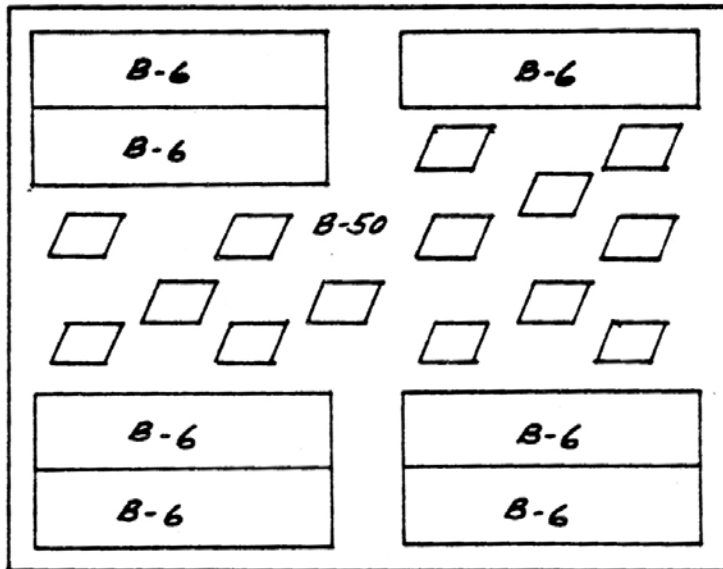

V | Shutters & trim

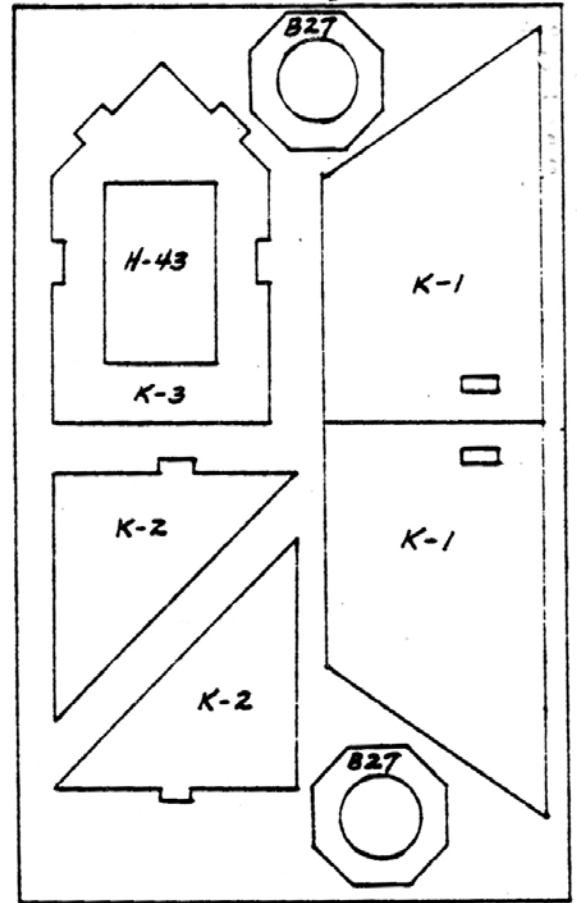

XVI | Dornier parts

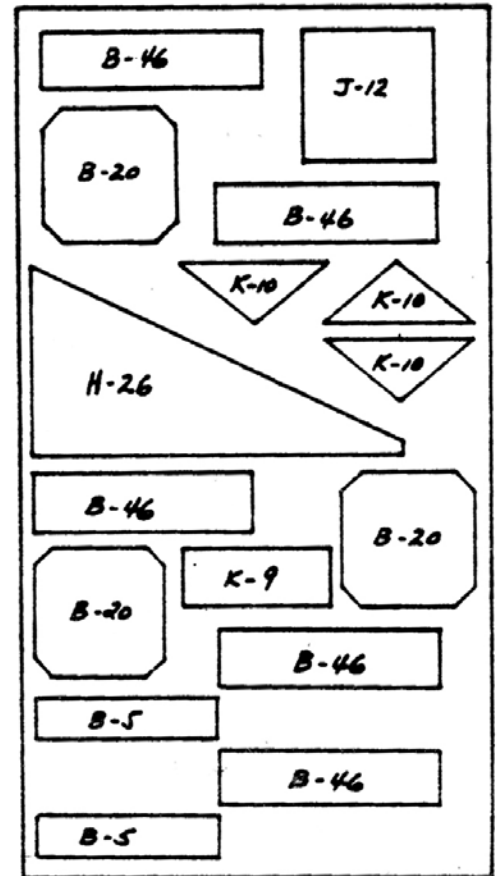

XII | Misc parts